

**Submersible motor pumps
 for domestic drainage water containing solids.
 Free passage 50 mm.**

TP48

Application

Submersible motor pumps in the TP48 series are used for conveying domestic drainage- and waste water as well as sludge. With their large free passage of 50 mm, they are particularly well suited for use with media containing coarse solids and fibers. Ideal for economical disposal in municipal, private, trade and industry applications.

DIN EN 12050-2: Design tested and monitored.

Installation: Stationary or mobile. Version with float switch for use as automatic water level controlled drainage pump.

Pumped medium: Clean water and waste water with solid and fibrous content.

Max. temperature of pumped medium: 40°C, for brief periods up to 60°C.

Operating mode: Submerged motor: Continuous operation (S1). Surfaced motor or medium temperature 41-60 °C: Intermittent operation (S3 30%)

Design

Fully submersible pump, consisting of:

Pump: Single-stage with horizontal discharge.

Impellers: M= open single-channel impeller for sludgy media with solids or fibrous content.

V = Vortex impeller for media containing gas or air, with coarse or long stringy components that are prone to clogging.

Motor: Fully submersible motor, sealed against pressurized water, oil-filled. Insulation class H, Protection rating IP68.

Single phase version with thermal sensor in the winding for temperature monitoring. Electrical compartment is separate from motor.

Connecting cable: H07RN-F 4G1,5

Model WA: H07RN-F 3G1,0

Shaft/bearing: strongly dimensioned chrome steel shaft, lifetime-lubricated roller bearings.

Seal: Combination of mechanical seal (silicon carbide/silicon carbide) and radial seal that is independent of the direction of rotation.

Conveying capacities

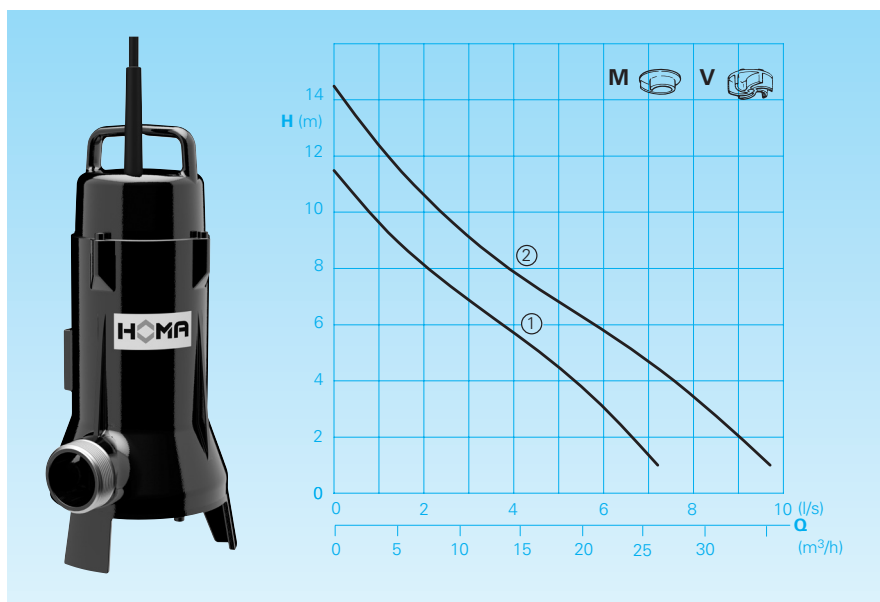

Technical data

Curve No.	Pump type	Motor input		Voltage 50 Hz (V)	Nominal current (A)	Weight (kg)
		P ₁ (kW)	P ₂ (kW)			
①	TP48V 15/2 W (A)	1,5	1,1	230/1Ph	6,5	22,0
①	TP48V 15/2 DL	1,5	1,1	400/3Ph	2,5	22,0
②	TP48M 15/2 W (A)	1,5	1,1	230/1Ph	6,5	22,0
②	TP48M 15/2 DL	1,5	1,1	400/3Ph	2,5	22,0

Rotational speed: 2900 rpm

Discharge: G2

Model A: with automatic HOMA-Nivomatik float switch

Model L: without switchgear, with loose cable end.

Materials

Pump housing, motor housing	Cast iron EN-GJL-250
Impeller, motor shaft	Stainless steel
Mechanical seal	SiC/SiC
Elastomers	NBR
Mechanical connection parts	Stainless steel

Scope of supply

Pump with base support, without drainage facility (see accessories)

Model W (230 V / 1 Ph):

With 10 m of connecting cable and mains plug.

Model WA: With 10 m of connecting cable, mains plug and float switch.

Model DL: Without switchgear, with loose cable end.

Shaft installation with automatic coupling system.
Twin unit Single unit

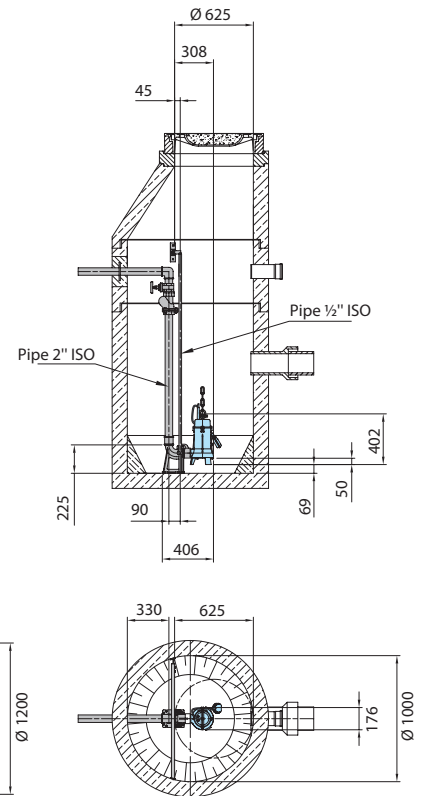
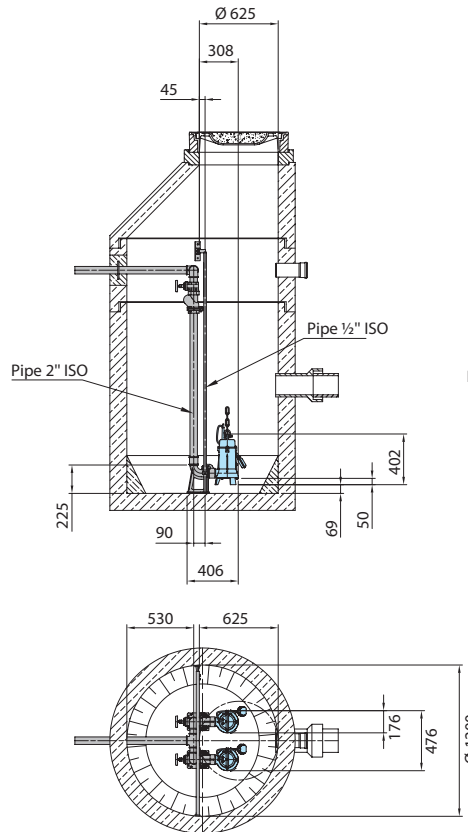
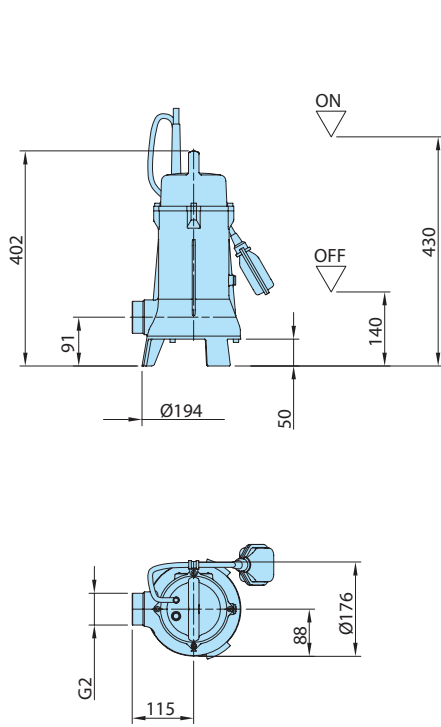

Accessories

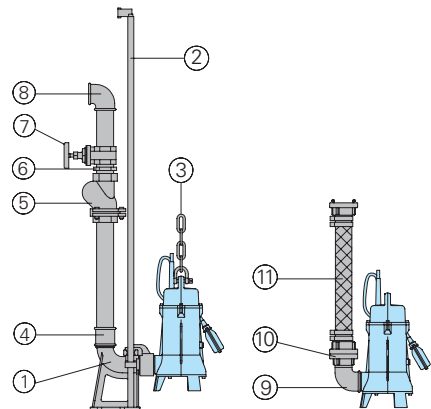

Description	Size	Part no.
① Automatic coupling system with mating flange, base elbow		
- Slide rail bracket GG KK50/BSP2"		8604005
- Slide rail bracket VA KKR50-1/BSP2"		8604019
○ Coupling system completely or partly in stainless steel	all	on request
○ Screw-Kits for fastening coupling systems		on request

Description	Size	Part no.
○ Intermediate bracket for slide rail bracket extension	Ø 1" for KKR50-1 Ø 1/2" for KK50	7323714 7320271
② Guide rails, in pairs, per m	Galvanized steel	
	Ø 1/2"	2190085
	Ø 1"	2190135
	Stainless steel	
	Ø 1/2"	2190250
	Ø 1"	2190252
③ Pump chain sets, tested. With shackle, single or dual row, different lengths and load bearing capacities		on request
④ Double socket, galvanized	BSP 2"F BSP 2"F/ BSP 1 1/2"F	2109102 2102210
⑤ Non-return ball valve GG	BSP 1 1/2"F BSP 2"F	2212902 2212903
⑥ Double nipple, galvanized	BSP 1 1/2"M BSP 2"M	2009020 2009018
⑦ Shut-off gate valve MS	BSP 1 1/2"F BSP 2"F	2216015 2216020
⑧ 90° bend, galvanized	BSP 1 1/2"F BSP 2"F	2113605 2113606
T-piece for merging the pressure pipe in double pump stations	BSP 1 1/2"F BSP 2"F	2114302 2114306
⑨ 90° bend, galvanized	BSP 2"F/M BSP 1 1/2"F/M	2111506 2111505
Double socket, galvanized	BSP2F/BSP1 1/2F	2102210

Description	Size	Part no.
⑩ STORZ-fixed coupling	C-G2"F	2010204
STORZ-hose-coupling	C-52 mm Ø	2013003
STA-threaded hose fitting, brass	BSP 1 1/2"F	2001513
⑪ Synthetic pressure hose, with rubber lining, with couplings	10 m long 15 m long 20 m long 30 m long	2611310 2611315 2611320 2611330
Plastic spiral hose, per m	Ø 50 mm	2632050
PVC-hose, per m	1 1/2" Ø 38 mm	2621500
Hose clamp	1 1/2" 2"	2304854 2306009
○ For pump controllers and switchgears for mobile and stationary applications, measuring systems and monitoring devices,		see HOMA accessories



We reserve the right to alter our specifications without notice!