

## Submersible Motor Pump

# Amarex N

50 Hz  
DN 50 - DN 100



## Type Series Booklet



## **Legal information/Copyright**

Type Series Booklet Amarex N

All rights reserved. The contents provided herein must neither be distributed, copied, reproduced, edited or processed for any other purpose, nor otherwise transmitted, published or made available to a third party without the manufacturer's express written consent.

Subject to technical modification without prior notice.

© KSB Aktiengesellschaft, Frankenthal 16.03.2016

Contents

<b>Waste Water .....</b>	<b>4</b>
Submersible Motor Pump .....	4
Amarex N .....	4
Main applications .....	4
Fluids handled .....	4
Operating data .....	4
Designation .....	4
Design details .....	4
Materials .....	5
Product benefits .....	6
Certifications .....	6
Programme overview / selection tables .....	6
Table of fluids handled .....	6
Overview of product features .....	8
Technical data .....	10
Characteristic curves .....	13
n = 2900 rpm .....	13
n = 1450 rpm .....	18
Dimensions and connections .....	23
Connections .....	23
Dimensions .....	24
Installation types .....	36
Installation information .....	37
Suggested installation layouts for transportable pump sets .....	37
Suggested installation layouts for stationary pump sets .....	38
Suggested electrical installation layouts .....	40
Scope of supply .....	40
Accessories .....	41
Installation parts for stationary pump sets .....	41
Installation parts for transportable pump sets .....	42
Chain for stationary and transportable pump sets .....	43
Pump accessories .....	43
Electrical accessories .....	45

## Waste Water

### Submersible Motor Pump

## Amarex N



### Main applications

- Waste water management
- Drainage systems
- Sewage treatment plants
- Sludge disposal
- Drainage of rooms and areas at risk of flooding on municipal, commercial and industrial premises

### Fluids handled

- Service water
- Grey water
- Waste water with faeces
- Waste water containing long fibres and solid substances
- Fluids containing gas
- Activated sludge
- Digested sludge
- Raw sludge

### Operating data

Operating properties

Characteristic		Value
Flow rate	Q [m <sup>3</sup> /h]	≤ 190
	Q [l/s]	≤ 53
Head	H [m]	≤ 49

Characteristic	Value	
Fluid temperature	T [°C]	≤ 40 <sup>1)</sup>
Motor rating	P <sub>2</sub> [kW]	0,8 - 4,2

### Designation

**Example: Amarex N F 80-220 / 04 4 YL G-220**

Designation key

Code	Description	
Amarex N	Type series	
F	Impeller type	
	F	Free-flow impeller
	S	Cutter
	D	Open, diagonal single-channel impeller
80-220	Size of hydraulic system	
04	Motor size	
4	Number of motor poles	
	2	2 poles
	4	4 poles
YL	Motor version	
	UL	Without explosion protection, for fluid temperatures of up to 55 °C
	YL <sup>2)</sup>	Without explosion protection, for fluid temperatures of up to 40 °C
	WL	Without explosion protection, for fluid temperatures of up to 60 °C
G	Material variant (⇒ Page 5)	
	G	Pump casing: grey cast iron EN-GJL-250 Intermediate casing: grey cast iron EN-GJL-250 Impeller: grey cast iron EN-GJL-250
	G1	Pump casing: grey cast iron EN-GJL-250 Intermediate casing: grey cast iron EN-GJL-250 Impeller: Noridur 1.4593 (duplex stainless steel)
	G2	Pump casing: grey cast iron EN-GJL-250 Intermediate casing: grey cast iron EN-GJL-250 Impeller: Norihard 0.9635 (white cast iron)
	GH	Pump casing: grey cast iron EN-GJL-250 Intermediate casing: Norihard 0.9635 (white cast iron) Impeller: Norihard 0.9635 (white cast iron)
220	Nominal impeller diameter [mm]	

### Design details

#### Design

- Fully floodable submersible motor pump
- Not self-priming
- Close-coupled design

#### Drive

- Three-phase asynchronous squirrel-cage motor
- Motors integrated in explosion-proof pump sets are supplied in Ex d IIB type of protection.

1) For short periods (3 to 5 minutes or until the temperature guards trip) UL and WL models can be operated at up to 80 °C.

2) In countries stipulating explosion-proof units for handling sewage with faeces, motor version YL must be used.

**Shaft seal**

- Two bi-directional mechanical seals in tandem arrangement, with liquid reservoir

**Impeller type**

- Various, application-based impeller types

D impeller:

	Open, diagonal single-vane impeller (impeller type D)	<b>Suitable for the following fluids:</b> fluids containing solid substances and long fibres
---	---	---

F impeller:

	Free-flow impeller (impeller type F)	<b>Suitable for the following fluids:</b> fluids containing solid substances and stringy material as well as fluids with entrapped air or gas
---	--------------------------------------	--

D and F impellers are suitable for handling the following fluids:

- Activated sludge
- Digested sludge
- Heating sludge
- Mixed water
- Raw waste water
- Raw sludge

- Recirculated sludge

S impeller:

	Impeller with cutter (impeller type S)	<b>Suitable for the following fluids:</b> faeces, domestic sewage and waste water containing long fibres
---	--	---

S impellers are suitable for handling the following fluids:

- Domestic waste water
- Grey water
- Waste water with faeces

**Standard bearings**

- Grease-lubricated bearings sealed for life
- Maintenance-free

**Reinforced bearings (optional, only for S impeller)**

The following hydraulic system/motor combinations can be equipped with reinforced bearings:

Reinforced bearings

Size of hydraulic system	Motor size and number of poles
Amarex N S 50-172 (motor version YL)	002, 012, 022
Amarex N S 50-222 (motor version YL)	032, 042

Pump-end bearings:

- Grease-lubricated bearing sealed for life

**Materials**

Overview of material variants for standard variants

Component	S impeller		D impeller		F impeller	
	Amarex N S 50-172/... Amarex N S 50-222/...		Amarex N D 80-220/... Amarex N D 100-220/...		Amarex N F 50-... Amarex N F 65-... Amarex N F 80-... Amarex N F 100-...	
		G	G	G	G	
Casing		EN-GJL-250	EN-GJL-250	EN-GJL-250	EN-GJL-250	
Intermediate casing		EN-GJL-250	EN-GJL-250	EN-GJL-250	EN-GJL-250	
Impeller		EN-GJL-250	EN-GJL-250	EN-GJL-250	EN-GJL-250	
Cutter		1.2080.02 (K100)	-	-	-	
Shaft		1.4021	1.4021	1.4021	1.4021	
Mechanical seal	Drive end	Carbon/Al <sub>2</sub> O <sub>3</sub>	Carbon/Al <sub>2</sub> O <sub>3</sub>	Carbon/Al <sub>2</sub> O <sub>3</sub>	Carbon/Al <sub>2</sub> O <sub>3</sub>	
	Pump end	SiC/SiC	SiC/SiC	SiC/SiC	SiC/SiC	
Screws/bolts		A2	A2	A2	A2	
Elastomers		NBR	NBR	NBR	NBR	

Overview of material variants for standard variants

Component	S impeller		D impeller		F impeller		
	Amarex N S 50-172/... Amarex N S 50-222/...		Amarex N D 80-220/... Amarex N D 100-220/...		Amarex N F 50-... Amarex N F 65-... Amarex N F 80-... Amarex N F 100-...		
		G	G	G1	G2	GH	
Casing		-	-	EN-GJL-250	EN-GJL-250	EN-GJL-250	
Intermediate casing		-	-	EN-GJL-250	EN-GJL-250	0.9635 <sup>4)</sup>	
Impeller		-	-	1.4593 <sup>3)</sup>	0.9635 <sup>4)</sup>	0.9635 <sup>4)</sup>	
Cutter		-	-	-	-	-	
Shaft		-	-	1.4021	1.4021	1.4021	

Component		S impeller	D impeller	F impeller		
		Amarex N S 50-172/... Amarex N S 50-222/...	Amarex N D 80-220/... Amarex N D 100-220/...	Amarex N F 50-... Amarex N F 65-... Amarex N F 80-... Amarex N F 100-...	G	G
		G	G	G1	G2	GH
Mechanical seal	Drive end	-	-	Carbon/Al <sub>2</sub> O <sub>3</sub>	Carbon/Al <sub>2</sub> O <sub>3</sub>	Carbon/Al <sub>2</sub> O <sub>3</sub>
	Pump end	-	-	SiC/SiC	SiC/SiC	SiC/SiC
Screws/bolts		-	-	A2	A2	A2
Elastomers		-	-	NBR <sup>5)</sup>	NBR <sup>5)</sup>	NBR <sup>5)</sup>

**Product benefits**

- Easy and fast installation/removal with polarised, absolutely watertight cable and KSB plug connection ensuring correct installation
- Motor absolutely watertight, also in the event of damage to the cable sheath and core insulation, with individually stripped, tinned and resin-sealed conductors
- Highest operating reliability with optimum motor selection for operating mode S1, thermal class F, explosion-proof variant in Ex d IIB T4 Gb
- Long service life with shaft made of corrosion-resistant stainless steel
- Zero maintenance, ideal for continuous duty, with long-life bearings sealed on both sides, grease-packed for life
- Environmentally friendly, non-toxic, food-approved oil fill for lubricating the mechanical seal (liquid reservoir)
- Significant reduction of energy costs by optimised hydraulic system and high efficiency
- Absolutely reliable and non-clogging design with optimised cutter (S impeller).
- Close-coupled pump design prevents risk of leakage (pump volute casing and motor housing cast as a single piece)
- Stationary pump sets easy to install and remove with automatic, bolt-free connection; leakage prevented by elastic sealing elements
- Ease of service with wetted bolts made of stainless steel, which are easy to undo even after years of operation
- Two bi-directional mechanical seals with oil reservoir filled with ecologically acceptable oil provide double safety

- Well suited for mechanical seal with covered spring for abrasive and aggressive fluids
- Only one set of spare parts for all pump sizes thanks to modular system

**Certifications**

Overview

Label	Valid in:	Comment
	Europe	Suitable for plants to Standard EN 12050-1
	Europe	BMW (test report) Nos.: 0420266-01 to 05

**Programme overview / selection tables**

**Table of fluids handled**

The table below for your guidance is based on KSB's long-standing experience. The data are standard values and are not to be considered as generally binding recommendations. More detailed advice is available from our specialist department. Make use of our laboratory's expertise when selecting materials.

Selection aid for materials and hydraulic systems per fluid

Fluid handled <sup>6)</sup>	Recommended material	Recommended impeller type <sup>7)</sup>	Comments, further recommendations
Grey water	EN-GJL-250	F, D, S	Free passage > any solids contained, possibly pre-screened
River water	EN-GJL-250	F, D	Free passage > any solids contained, possibly pre-screened
Contaminated surface water	EN-GJL-250	F, D	Free passage > any solids contained, possibly pre-screened
<b>Waste water</b>			
▪ Untreated municipal waste water	EN-GJL-250	F, D, S	ATV <sup>8)</sup> recommends a free passage of 100 mm; min. free passage: 76 mm

3) Noridur (= duplex stainless steel)  
 4) Norihard (= white cast iron)  
 5) Optional: FPM  
 6) For any fluids which are not listed in this table contact KSB.  
 7) The first impeller type listed should be given preference.  
 8) ATV = German regulatory body for waste water management

Fluid handled <sup>6)</sup>	Recommended material	Recommended impeller type <sup>7)</sup>	Comments, further recommendations
<ul style="list-style-type: none"> <li>▪ Waste water containing air or gas</li> </ul>	EN-GJL-250	F	Up to 8 %, contact KSB for handling fluids with high outgassing rates
<ul style="list-style-type: none"> <li>▪ Raw waste water</li> </ul>	EN-GJL-250	F, D	ATV <sup>8)</sup> recommends a free passage of 100 mm; min. free passage: 76 mm
<ul style="list-style-type: none"> <li>▪ Mixed water</li> </ul>	EN-GJL-250	F	Free passage > any solids contained, possibly pre-screened
<ul style="list-style-type: none"> <li>▪ Waste water or grey water containing long fibres</li> </ul>	EN-GJL-250	F, D, S	Free passage > any solids contained, possibly pre-screened
<ul style="list-style-type: none"> <li>▪ Highly abrasive waste water causing wear (chemically neutral)</li> </ul>	Norihard	F	For solids contents < 5 g/l material variants G2, GH
<ul style="list-style-type: none"> <li>▪ Corrosive waste water</li> </ul>	Noridur	F	Material variant G1 if required according to analysis of the fluid handled
<b>Sludges</b>			
<ul style="list-style-type: none"> <li>▪ Raw sludge</li> </ul>	EN-GJL-250	D, F	Pumpable up to a dry substance content of: 13 % (D), 8 % (F)
<ul style="list-style-type: none"> <li>▪ Digested sludge</li> </ul>	EN-GJL-250	D, F	Pumpable up to a dry substance content of: 13 % (D), 8 % (F)
<ul style="list-style-type: none"> <li>▪ Activated sludge</li> </ul>	EN-GJL-250	D, F	Pumpable up to a dry substance content of: 13 % (D), 8 % (F)
<b>Industrial waste water containing ...</b>			
<ul style="list-style-type: none"> <li>▪ Paint suspensions</li> </ul>	EN-GJL-250	F	Solvent-free, observe the operator's instructions.
<ul style="list-style-type: none"> <li>▪ Lacquer/paint/varnish suspensions</li> </ul>	EN-GJL-250	F	Solvent-free, contact KSB for silicone-free version.
<ul style="list-style-type: none"> <li>▪ Fibres/pulp</li> </ul>	EN-GJL-250	F, S, D	
<ul style="list-style-type: none"> <li>▪ Chips/swarf</li> </ul>	Norihard	F	Material variant G2 or GH, special mechanical seal; solids content < 5 g/l
<ul style="list-style-type: none"> <li>▪ Abrasive substances<sup>9)</sup></li> </ul>	Norihard	F	Material variant G2 or GH, special mechanical seal; solids content < 5 g/l
<b>Mildly acidic industrial waste water</b>	EN-GJL-250	F	pH value ≥ 6.5 G1 variant and FPM (Viton) O-rings
<b>Non-corrosive waste water</b>			
<ul style="list-style-type: none"> <li>▪ Ammonium water</li> </ul>	EN-GJL-250	F	
<ul style="list-style-type: none"> <li>▪ Ammonium hydroxide 5 % NH<sub>4</sub>OH</li> </ul>	EN-GJL-250	F	
<ul style="list-style-type: none"> <li>▪ Urea 25 % (NH<sub>2</sub>)<sub>2</sub>-CO</li> </ul>	EN-GJL-250	F	
<ul style="list-style-type: none"> <li>▪ Potassium hydroxide 10 % KOH</li> </ul>	EN-GJL-250	F	
<ul style="list-style-type: none"> <li>▪ Calcium hydroxide 5 % Ca(OH)<sub>2</sub></li> </ul>	EN-GJL-250	F	
<ul style="list-style-type: none"> <li>▪ Sodium hydroxide 5 % NaOH</li> </ul>	EN-GJL-250	F	
<ul style="list-style-type: none"> <li>▪ Sodium carbonate 30 % Na<sub>2</sub>CO<sub>3</sub></li> </ul>	EN-GJL-250	F	
<b>Non-corrosive waste water containing ...</b>			
<ul style="list-style-type: none"> <li>▪ Aliphatic hydrocarbons, e.g. oils, petrol, butane, methane</li> </ul>	EN-GJL-250	F	FPM (Viton) O-rings, TEHSITE cable, for high concentrations contact KSB.
<ul style="list-style-type: none"> <li>▪ Aromatic hydrocarbons, e.g. benzene, styrene</li> </ul>	EN-GJL-250	F	FPM (Viton) O-rings, TEHSITE cable, for high concentrations contact KSB.
<ul style="list-style-type: none"> <li>▪ Chlorinated hydrocarbons (e.g. tetrachloroethylene, ethylene chloride, chloroform, methylene chloride)</li> </ul>	EN-GJL-250	F	FPM (Viton) O-rings, TEHSITE cable, for high concentrations contact KSB.
<b>Highly abrasive industrial waste water causing wear (chemically neutral)<sup>10)</sup></b>			
<ul style="list-style-type: none"> <li>▪ Lime water</li> </ul>	Norihard	F	For sinter contents < 5 g/l, material variant GH
<ul style="list-style-type: none"> <li>▪ Lime milk containing quartz and pigment suspension</li> </ul>	Norihard	F	Lime milk of up to 15 %, material variant GH
<ul style="list-style-type: none"> <li>▪ Water/sand mixture</li> </ul>	Norihard	F	Up to 5 g/l solids content, material variant GH

6) For any fluids which are not listed in this table contact KSB.

7) The first impeller type listed should be given preference.

9) Severe hydroabrasive wear occurs if solids contents of approx. 0.5 g/l or higher are combined with circumferential speeds exceeding 20 m/s or low-flow conditions to the left of the duty point.

10) The material variants required highly depend on the operating hours, rotational speed and flow velocity.

## Overview of product features

Standard designs

Size	S impeller	D impeller	F impeller
	Amarex N S 50-...	Amarex N D 80-... Amarex N D 100-...	Amarex N F 50-... Amarex N F 65-... Amarex N F 80-... Amarex N F 100-...
<b>Material variant</b>	<b>G</b>	<b>G</b>	<b>G</b>
<b>Number of motor poles</b>			
2-pole	50-172/... 50-222/...	-	50-170/... 50-220/... 65-170/...
4-pole	-	80-220/... 100-220/...	65-220/... 80-220/... 100-200/...
<b>Explosion protection</b>			
Motor version UL	Non-explosionproof		
Motor version YL <sup>11)</sup>	⊕ Ex d IIB T4 Gb		
Motor version WL	Non-explosionproof		
<b>Motor</b>			
Starting method	DOL <sup>12)</sup>		
Voltage	400 V		
Cooling	Cooled by surrounding fluid		
Mode of operation	S1: submerged (max. 25 m) (see <sup>2)</sup> in outline drawing) S3: outside the fluid (see <sup>1)</sup> in outline drawing)		
<b>Power cable</b>			
Type	Rubber-sheathed cable (H07RN8-F 7G1.5 <sup>2)</sup> )		
Length	10 m		
Cable entry	Absolutely watertight		
<b>Sealing elements</b>			
Shaft seal	Mechanical seal		
Elastomer seals	NBR		
<b>Monitoring equipment</b>			
Winding temperature version YL	Temperature monitoring circuit (with automatic reset and start-up): bimetal switch directly connected with the control circuit of the motor contactor Limiting circuit (temperature limit for explosion protection without automatic reset): bimetal switch connected via a tripping unit with manual reset		
Winding temperature version UL, WL	Temperature monitoring circuit (with automatic reset and start-up): bimetal switch directly connected with the control circuit of the motor		
<b>Coating</b>	Environmentally-friendly KSB top coat (two-component epoxy paint), colour RAL 5002, film thickness = 80 µm		
<b>Installation</b> (⇒ Page 36)			
Stationary, with guide hoop	Installation depths 1.5 m/1.8 m/2.1 m		
Stationary, with single guide rail	Installation depth 4.5 m		
Stationary, with twin guide rail	Installation depth 4.5 m		
Stationary, with guide wire	Installation depth 4.5 m		
Transportable	Installation depth 4.5 m		
<b>Maximum temperature of fluid handled</b>			
Motor version UL	55 °C		
Motor version YL	40 °C		
Motor version WL	60 °C		

11) In countries stipulating explosion-proof units for handling sewage with faeces, motor version YL must be used.

12) Maximum switching frequency: 30 starts per hour



Standard variants

Size	S impeller	D impeller	F impeller		
	Amarex N S 50-172/... Amarex N S 50-222/...	Amarex N D 80-220/... Amarex N D 100-220/...	Amarex N F 50-... Amarex N F 65-... Amarex N F 80-... Amarex N F 100-...		
Material variants	G	G	G1	G2	GH
<b>Number of motor poles</b>					
2-pole	-	-	50-170/... 50-220/... 65-170/...		
4-pole	-	-	65-220/... 80-220/... 100-200/...		
<b>Shaft material</b>					
Material 1.4462 + C45 N	X	X	X		
<b>Motor</b>					
Voltage	230 V, 415 V, 500 V, 690 V				
<b>Monitoring equipment</b>					
Leakage sensor in the motor space <sup>13)</sup>	X	X	X		
<b>Suction flange</b>					
Drilled to DIN/ISO PN16 or ASME 150 lb	-	-	X		
<b>Sealing elements</b>					
<b>Elastomers:</b> O-rings and flange gaskets made of Viton, lower mechanical seal with Viton gaskets	X	X	X		
<b>Shaft seal:</b> special mechanical seal (mechanical seal with covered spring HJ977) <sup>14)</sup>	X	X	X		
<b>Power cables</b>					
Standard rubber-sheathed cable (H07RN8-F 7G1.5 <sup>2)</sup> ; for versions ULG, YLG, WLG <sup>15)</sup>	X	X	X		
Standard rubber-sheathed cable (H07RN8-F 8x1.5 <sup>2)</sup> for pump with leakage sensor <sup>15)</sup>	X	X	X		
TEHSITE power cable (8G1.5) for pump with or without leakage sensor, for versions ULG, YLG, WLG <sup>16)</sup>	X	X	X		
Shielded rubber-sheathed cable (S07RC4N8-F-8G1.5) for pump with or without leakage sensor, for versions ULG, YLG, WLG operated on a frequency inverter <sup>16)</sup>	X	X	X		
<b>Coating</b>	Environmentally-friendly KSB standard coating (two-component epoxy paint), colour RAL 5002, film thickness = 300 µm				
<b>Installation</b> (⇒ Page 36)					
Stationary, with guide hoop	Installation depths 1.5 m/1.8 m/2.1 m				
Stationary, with single guide rail	Installation depth 6.0 m				
Stationary, with twin guide rail	Installation depth 6.0 m				
Stationary, with guide wire	Installation depth 9.5 m				
Transportable	Installation depth 4.5 m				

<sup>13)</sup> 8-core connection cable required

<sup>14)</sup> Silicon carbide/silicon carbide seal faces, Viton sealing elements, stainless steel spring and metal part, Viton (FPM) O-rings and flange gaskets

<sup>15)</sup> Total lengths available 15 m/20 m/30 m/40 m/50 m

<sup>16)</sup> Total lengths available 10 m/15 m/20 m/30 m/40 m/50 m

**Technical data**

Material variant G

Impeller diameter	Size	Motor version	P <sub>1</sub>	P <sub>N</sub>	I <sub>N</sub>	I <sub>A</sub>	τ <sup>17)</sup>	[kg]	Mat. No.
			[kW]	[kW]	[A]	[A]	[°C]		
120	S 50-172/002	UL	1,83	1,30	3,58	20	55	47	39100017
	S 50-172/002	YL	1,83	1,30	3,58	20	40	47	39100018
	S 50-172/002	WL	1,83	1,30	3,58	20	60	39	-
140	S 50-172/002	UL	1,83	1,30	3,58	20	55	47	39100019
	S 50-172/002	YL	1,83	1,30	3,58	20	40	47	39100020
	S 50-172/002	WL	1,83	1,30	3,58	20	60	39	-
160	S 50-172/012	UL	2,64	1,90	4,67	20	55	47	39100021
	S 50-172/012	YL	2,64	1,90	4,67	20	40	47	39100022
	S 50-172/012	WL	2,64	1,90	4,67	20	60	39	-
175	S 50-222/032	UL	3,90	3,10	6,90	50	55	58	39100041
	S 50-222/032	YL	3,90	3,10	6,90	50	40	58	39100042
	S 50-222/032	WL	3,90	3,10	6,90	50	55	54	-
190	S 50-222/042	UL	5,40	4,20	9,00	50	55	58	39100043
	S 50-222/042	YL	5,40	4,20	9,00	50	40	58	39100044
	S 50-222/042	WL	5,40	4,20	9,00	50	55	54	-
90	F 50-170/002	UL	1,83	1,30	3,58	20	55	41	39100045
	F 50-170/002	YL	1,83	1,30	3,58	20	40	41	39100046
	F 50-170/002	WL	1,83	1,30	3,58	20	60	41	-
107	F 50-170/002	UL	1,83	1,30	3,58	20	55	41	39100047
	F 50-170/002	YL	1,83	1,30	3,58	20	40	41	39100048
	F 50-170/002	WL	1,83	1,30	3,58	20	60	41	-
120	F 50-170/012	UL	2,64	1,90	4,67	20	55	42	39100049
	F 50-170/012	YL	2,64	1,90	4,67	20	40	42	39100050
	F 50-170/012	WL	2,64	1,90	4,67	20	60	42	-
130	F 50-170/022	UL	3,30	2,30	5,61	20	55	42	39100051
	F 50-170/022	YL	3,30	2,30	5,61	20	40	42	39100052
	F 50-170/022	WL	3,30	2,30	5,61	20	60	43	-
140	F 50-170/022	UL	3,30	2,30	5,61	20	55	43	39100053
	F 50-170/022	YL	3,30	2,30	5,61	20	40	43	39100054
	F 50-170/022	WL	3,30	2,30	5,61	20	60	43	-
130	F 50-220/032	UL	3,90	3,10	6,90	50	55	52	39100067
	F 50-220/032	YL	3,90	3,10	6,90	50	40	52	39100068
	F 50-220/032	WL	3,90	3,10	6,90	50	60	52	-
140	F 50-220/032	UL	3,90	3,10	6,90	50	55	52	39100069
	F 50-220/032	YL	3,90	3,10	6,90	50	40	52	39100070
	F 50-220/032	WL	3,90	3,10	6,90	50	60	52	-
150	F 50-220/042	UL	5,40	4,20	9,00	50	55	53	39100071
	F 50-220/042	YL	5,40	4,20	9,00	50	40	53	39100072
	F 50-220/042	WL	5,40	4,20	9,00	50	60	54	-
160	F 50-220/042	UL	5,40	4,20	9,00	50	55	53	39100073
	F 50-220/042	YL	5,40	4,20	9,00	50	40	53	39100074
	F 50-220/042	WL	5,40	4,20	9,00	50	60	54	-
170	F 50-220/042	UL	5,40	4,20	9,00	50	55	54	39100075
	F 50-220/042	YL	5,40	4,20	9,00	50	40	54	39100076
	F 50-220/042	WL	5,40	4,20	9,00	50	60	54	-
180	F 50-220/042	UL	5,40	4,20	9,00	50	55	54	39100077
	F 50-220/042	YL	5,40	4,20	9,00	50	40	54	39100078
	F 50-220/042	WL	5,40	4,20	9,00	50	60	54	-
120	F 65-170/032	UL	3,90	3,10	6,90	50	55	58	39100085
	F 65-170/032	YL	3,90	3,10	6,90	50	40	58	39100086
	F 65-170/032	WL	3,90	3,10	6,90	50	60	59	-
128	F 65-170/032	UL	3,90	3,10	6,90	50	55	58	39100087
	F 65-170/032	YL	3,90	3,10	6,90	50	40	58	39100088
	F 65-170/032	WL	3,90	3,10	6,90	50	60	59	-
136	F 65-170/032	UL	3,90	3,10	6,90	50	55	59	39100089
	F 65-170/032	YL	3,90	3,10	6,90	50	40	59	39100090
	F 65-170/032	WL	3,90	3,10	6,90	50	60	59	-
146	F 65-170/042	UL	5,40	4,20	9,00	50	55	59	39100091

17) Fluid temperature

Impeller diameter	Size	Motor version	P <sub>1</sub>	P <sub>N</sub>	I <sub>N</sub>	I <sub>A</sub>	T <sup>17)</sup>	[kg]	Mat. No.
			[kW]	[kW]	[A]	[A]	[°C]		
	F 65-170/042	YL	5,40	4,20	9,00	50	40	59	39100092
	F 65-170/042	WL	5,40	4,20	9,00	50	60	60	-
152	F 65-170/042	UL	5,40	4,20	9,00	50	55	60	39100093
	F 65-170/042	YL	5,40	4,20	9,00	50	40	60	39100094
158	F 65-170/042	WL	5,40	4,20	9,00	50	60	60	-
	F 65-170/042	YL	5,40	4,20	9,00	50	40	60	39100095
112	F 65-170/042	WL	5,40	4,20	9,00	50	60	60	39100096
	F 65-170/042	YL	5,40	4,20	9,00	50	40	60	-
125	F 65-220/004	UL	1,29	0,80	2,90	17,4	55	49	39100097
	F 65-220/004	YL	1,29	0,80	2,90	17,4	40	49	39100098
	F 65-220/004	WL	1,29	0,80	2,90	17,4	60	49	-
135	F 65-220/004	UL	1,29	0,80	2,90	17,4	55	49	39100099
	F 65-220/004	YL	1,29	0,80	2,90	17,4	40	49	39100100
	F 65-220/004	WL	1,29	0,80	2,90	17,4	60	49	-
145	F 65-220/004	UL	1,29	0,80	2,90	17,4	55	49	39100101
	F 65-220/004	YL	1,29	0,80	2,90	17,4	40	49	39100102
	F 65-220/004	WL	1,29	0,80	2,90	17,4	60	49	-
155	F 65-220/004	UL	1,29	0,80	2,90	17,4	55	49	39100103
	F 65-220/004	YL	1,29	0,80	2,90	17,4	40	49	39100104
	F 65-220/004	WL	1,29	0,80	2,90	17,4	60	49	-
165	F 65-220/004	UL	1,29	0,80	2,90	17,4	55	49	39100105
	F 65-220/004	YL	1,29	0,80	2,90	17,4	40	49	39100106
	F 65-220/004	WL	1,29	0,80	2,90	17,4	60	49	-
175	F 65-220/014	UL	1,96	1,30	3,60	17,4	55	50	39100107
	F 65-220/014	YL	1,96	1,30	3,60	17,4	40	50	39100108
	F 65-220/014	WL	1,96	1,30	3,60	17,4	60	50	-
185	F 65-220/014	UL	1,96	1,30	3,60	17,4	55	50	39100109
	F 65-220/014	YL	1,96	1,30	3,60	17,4	40	50	39100110
	F 65-220/014	WL	1,96	1,30	3,60	17,4	60	50	-
195	F 65-220/024	UL	2,85	1,80	4,80	17,4	55	51	39100111
	F 65-220/024	YL	2,85	1,80	4,80	17,4	40	51	39100112
	F 65-220/024	WL	2,85	1,80	4,80	17,4	60	51	-
120	F 65-220/024	UL	2,85	1,80	4,80	17,4	55	51	39100113
	F 65-220/024	YL	2,85	1,80	4,80	17,4	40	51	39100114
	F 65-220/024	WL	2,85	1,80	4,80	17,4	60	51	-
135	F 80-220/034	UL	2,70	1,90	6,14	37,5	55	63	39100123
	F 80-220/034	YL	2,70	1,90	6,14	37,5	40	63	39100124
	F 80-220/034	WL	2,70	1,90	6,14	37,5	60	63	-
150	F 80-220/034	UL	2,70	1,90	6,14	37,5	55	63	39100137
	F 80-220/034	YL	2,70	1,90	6,14	37,5	40	63	39100138
	F 80-220/034	WL	2,70	1,90	6,14	37,5	60	63	-
165	F 80-220/034	UL	2,70	1,90	6,14	37,5	55	63	39100139
	F 80-220/034	YL	2,70	1,90	6,14	37,5	40	63	39100140
	F 80-220/034	WL	2,70	1,90	6,14	37,5	60	63	-
180	F 80-220/034	UL	3,61	2,60	7,00	37,5	55	63	39100129
	F 80-220/034	YL	3,61	2,60	7,00	37,5	40	63	39100130
	F 80-220/034	WL	3,61	2,60	7,00	37,5	60	64	-
195	F 80-220/044	UL	5,39	3,70	9,30	37,5	55	65	39100131
	F 80-220/044	YL	5,39	3,70	9,30	37,5	40	65	39100132
	F 80-220/044	WL	5,39	3,70	9,30	37,5	60	66	-
210	F 80-220/044	UL	5,39	3,70	9,30	37,5	55	65	39100133
	F 80-220/044	YL	5,39	3,70	9,30	37,5	40	65	39100134
	F 80-220/044	WL	5,39	3,70	9,30	37,5	60	66	-
120	F 80-220/044	UL	5,39	3,70	9,30	37,5	55	65	39100135
	F 80-220/044	YL	5,39	3,70	9,30	37,5	40	65	39100136
	F 80-220/044	WL	5,39	3,70	9,30	37,5	60	66	-
135	F 100-220/034	UL	2,70	1,90	6,14	37,5	55	64	39100145
	F 100-220/034	YL	2,70	1,90	6,14	37,5	40	64	39100146
	F 100-220/034	WL	2,70	1,90	6,14	37,5	60	64	-
	F 100-220/034	UL	2,70	1,90	6,14	37,5	55	64	39100159

<sup>17)</sup> Fluid temperature

Impeller diameter	Size	Motor version	P <sub>1</sub>	P <sub>N</sub>	I <sub>N</sub>	I <sub>A</sub>	T <sup>17)</sup>	[kg]	Mat. No.
			[kW]	[kW]	[A]	[A]	[°C]		
	F 100-220/034	YL	2,70	1,90	6,14	37,5	40	64	39100160
	F 100-220/034	WL	2,70	1,90	6,14	37,5	60	64	-
150	F 100-220/034	UL	3,61	2,60	7,00	37,5	55	64	39100149
	F 100-220/034	YL	3,61	2,60	7,00	37,5	40	64	39100150
165	F 100-220/034	WL	3,61	2,60	7,00	37,5	60	64	-
	F 100-220/044	UL	5,39	3,70	9,30	37,5	55	65	39100151
	F 100-220/044	YL	5,39	3,70	9,30	37,5	40	65	39100152
	F 100-220/044	WL	5,39	3,70	9,30	37,5	60	67	-
180	F 100-220/044	UL	5,39	3,70	9,30	37,5	55	66	39100153
	F 100-220/044	YL	5,39	3,70	9,30	37,5	40	66	39100154
	F 100-220/044	WL	5,39	3,70	9,30	37,5	60	67	-
	F 100-220/044	UL	5,39	3,70	9,30	37,5	55	67	39100155
195	F 100-220/044	YL	5,39	3,70	9,30	37,5	40	67	39100156
	F 100-220/044	WL	5,39	3,70	9,30	37,5	60	67	-
210	F 100-220/044	UL	5,39	3,70	9,30	37,5	55	67	39100157
	F 100-220/044	YL	5,39	3,70	9,30	37,5	40	67	39100158
	F 100-220/044	WL	5,39	3,70	9,30	37,5	60	67	-
	D 80-220/034	UL	2,70	1,90	6,14	37,5	55	74	39100345
154	D 80-220/034	YL	2,70	1,90	6,14	37,5	40	74	39100346
	D 80-220/034	WL	2,70	1,90	6,14	37,5	60	75	-
168	D 80-220/034	UL	2,70	1,90	6,14	37,5	55	74	39100347
	D 80-220/034	YL	2,70	1,90	6,14	37,5	40	74	39100348
	D 80-220/034	WL	2,70	1,90	6,14	37,5	60	75	-
	D 80-220/034	UL	2,70	1,90	6,14	37,5	55	74	39100349
180	D 80-220/034	YL	2,70	1,90	6,14	37,5	40	74	39100350
	D 80-220/034	WL	2,70	1,90	6,14	37,5	60	75	-
190	D 80-220/034	UL	2,70	1,90	6,14	37,5	55	75	39100351
	D 80-220/034	YL	2,70	1,90	6,14	37,5	40	75	39100352
	D 80-220/034	WL	2,70	1,90	6,14	37,5	60	75	-
	D 100-220/034	UL	3,61	2,60	7,00	37,5	55	79	39100366
195	D 100-220/034	YL	3,61	2,60	7,00	37,5	40	79	39100367
	D 100-220/034	WL	3,61	2,60	7,00	37,5	60	79	-
209	D 100-220/044	UL	5,39	3,70	9,30	37,5	55	79	39100368
	D 100-220/044	YL	5,39	3,70	9,30	37,5	40	79	39100369
	D 100-220/044	WL	5,39	3,70	9,30	37,5	60	80	-
	D 100-220/044	UL	5,39	3,70	9,30	37,5	55	80	39100370
220	D 100-220/044	YL	5,39	3,70	9,30	37,5	40	80	39100371
	D 100-220/044	WL	5,39	3,70	9,30	37,5	60	80	-

<sup>17)</sup> Fluid temperature

Characteristic curves

n = 2900 rpm

Amarex N S 50-172, n = 2900 rpm

Characteristic curves to ISO 9906 Class 2A / 3B, below 10 kW to § 4.4.2. They refer to the effective motor speed.

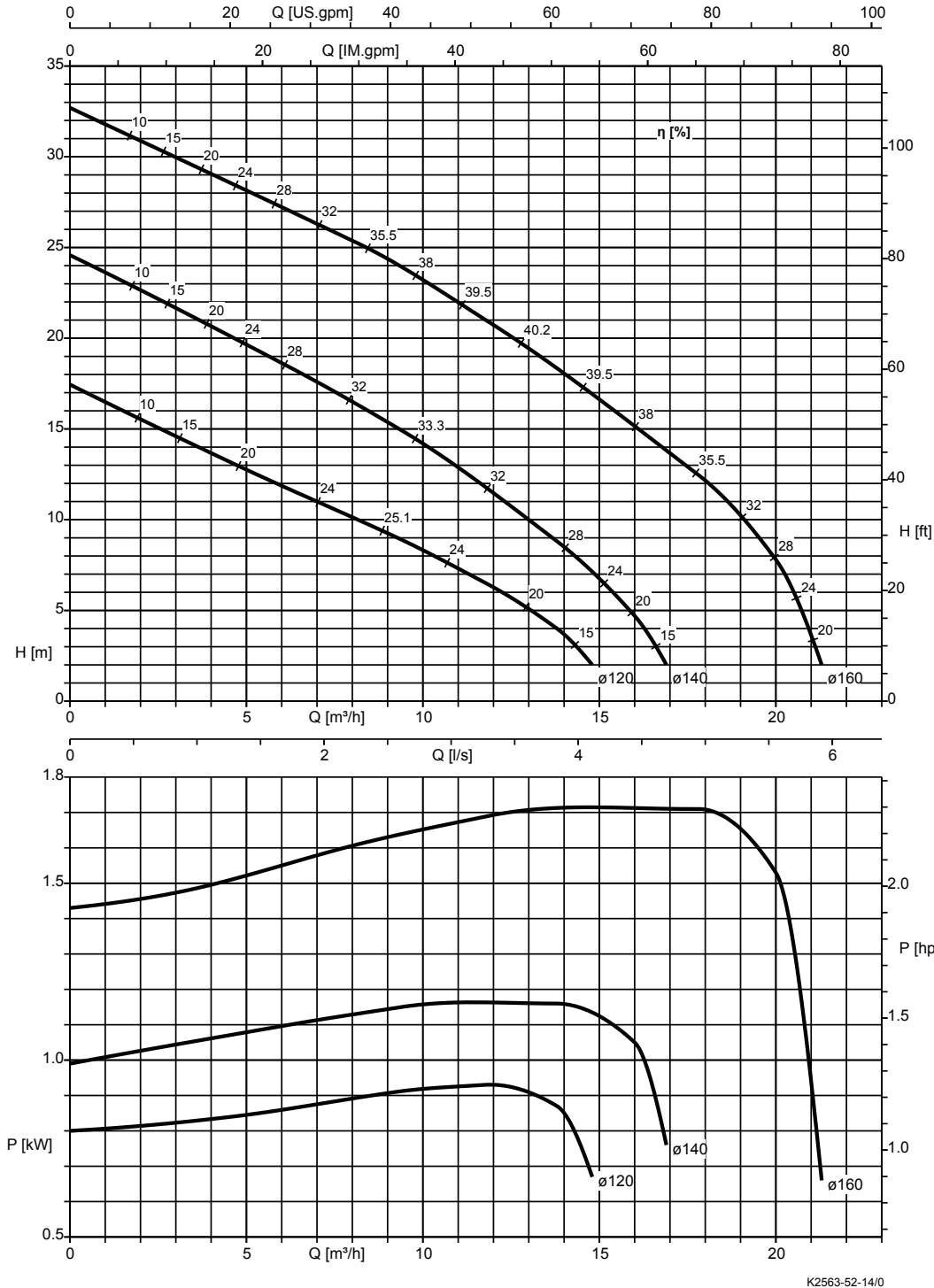

Free passage = 6 mm

**Amarex N S 50-222, n = 2900 rpm**

Characteristic curves to ISO 9906 Class 2A / 3B, below 10 kW to § 4.4.2. They refer to the effective motor speed.

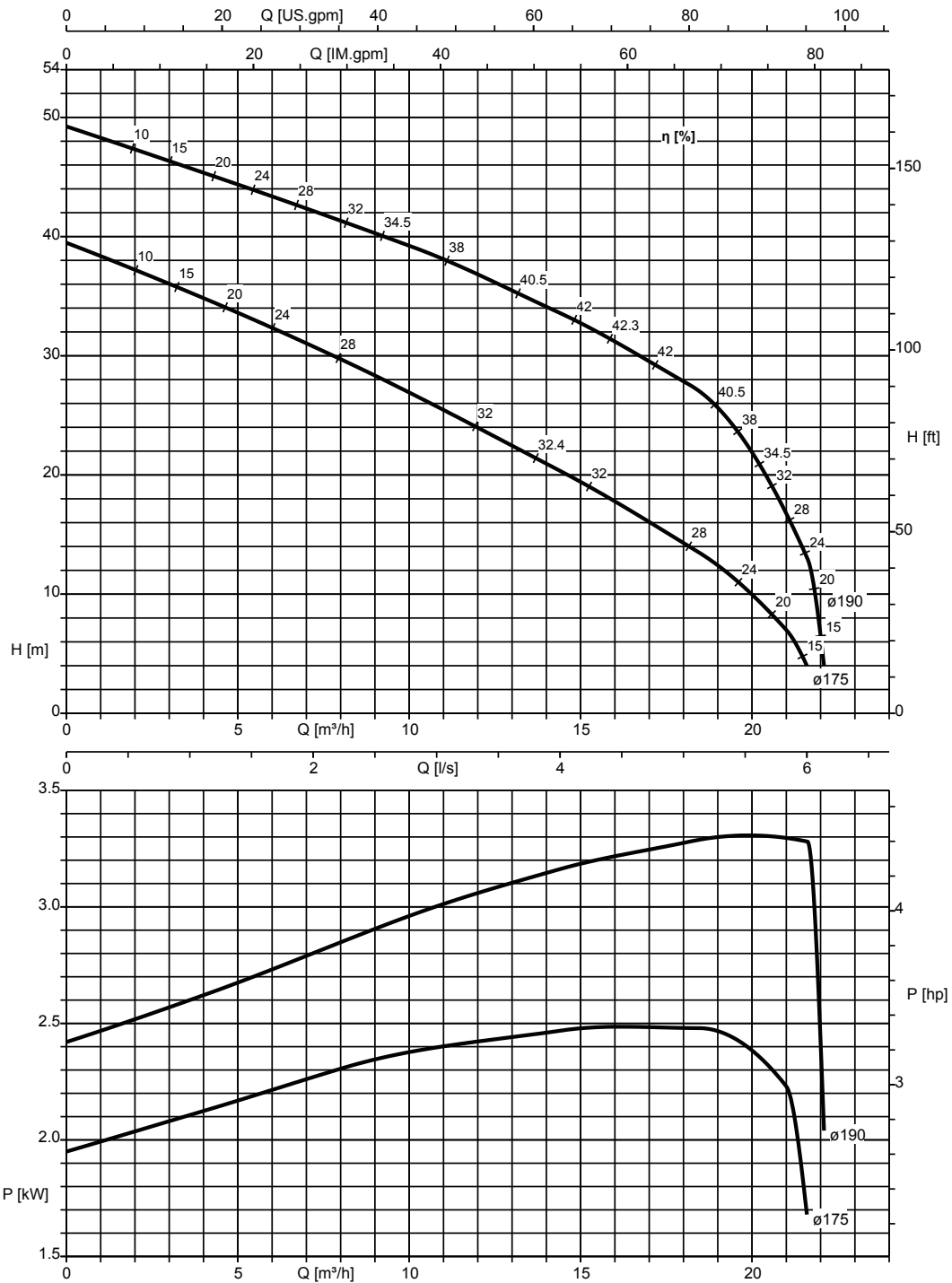

K2563-52-15/0

Free passage = 6 mm

**Amarex N F 50-170, n = 2900 rpm**

Characteristic curves to ISO 9906 Class 2A / 3B, below 10 kW to § 4.4.2. They refer to the effective motor speed.

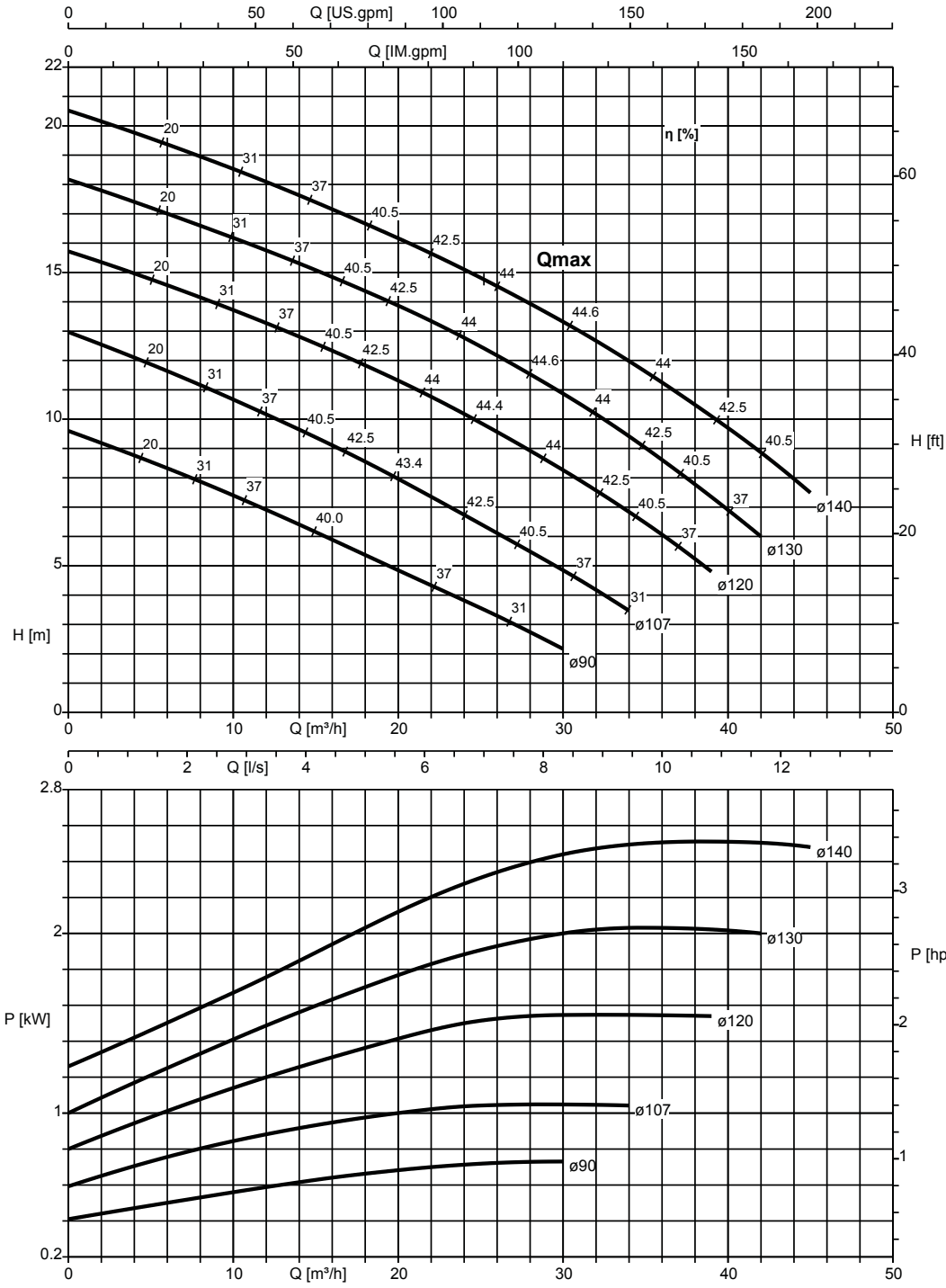

Free passage = 40 mm

**Amarex N F 50-220, n = 2900 rpm**

Characteristic curves to ISO 9906 Class 2A / 3B, below 10 kW to § 4.4.2. They refer to the effective motor speed.

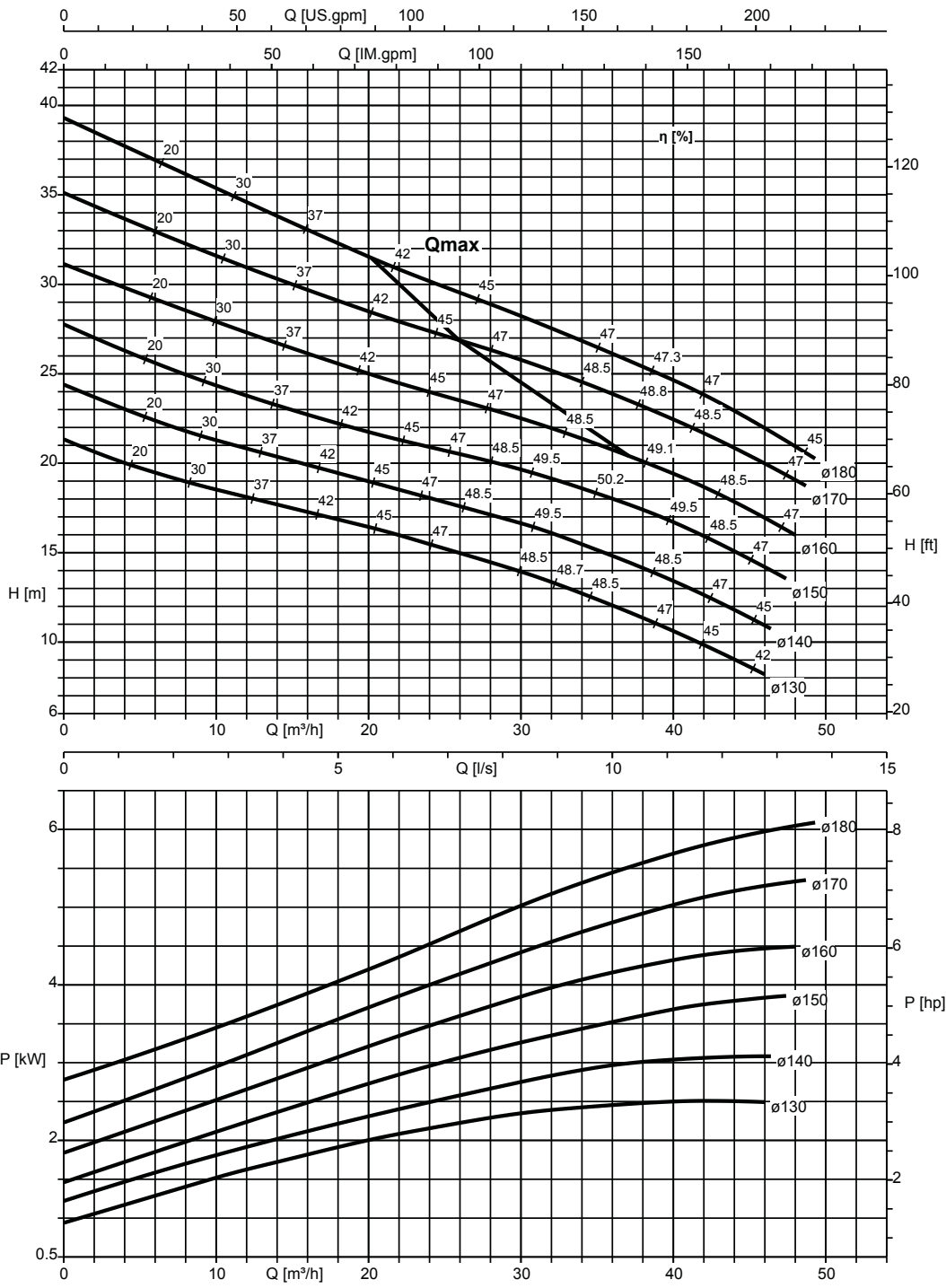

K2563-52-04/0

Free passage = 40 mm



**Amarex N F 65-170, n = 2900 rpm**

Characteristic curves to ISO 9906 Class 2A / 3B, below 10 kW to § 4.4.2. They refer to the effective motor speed.

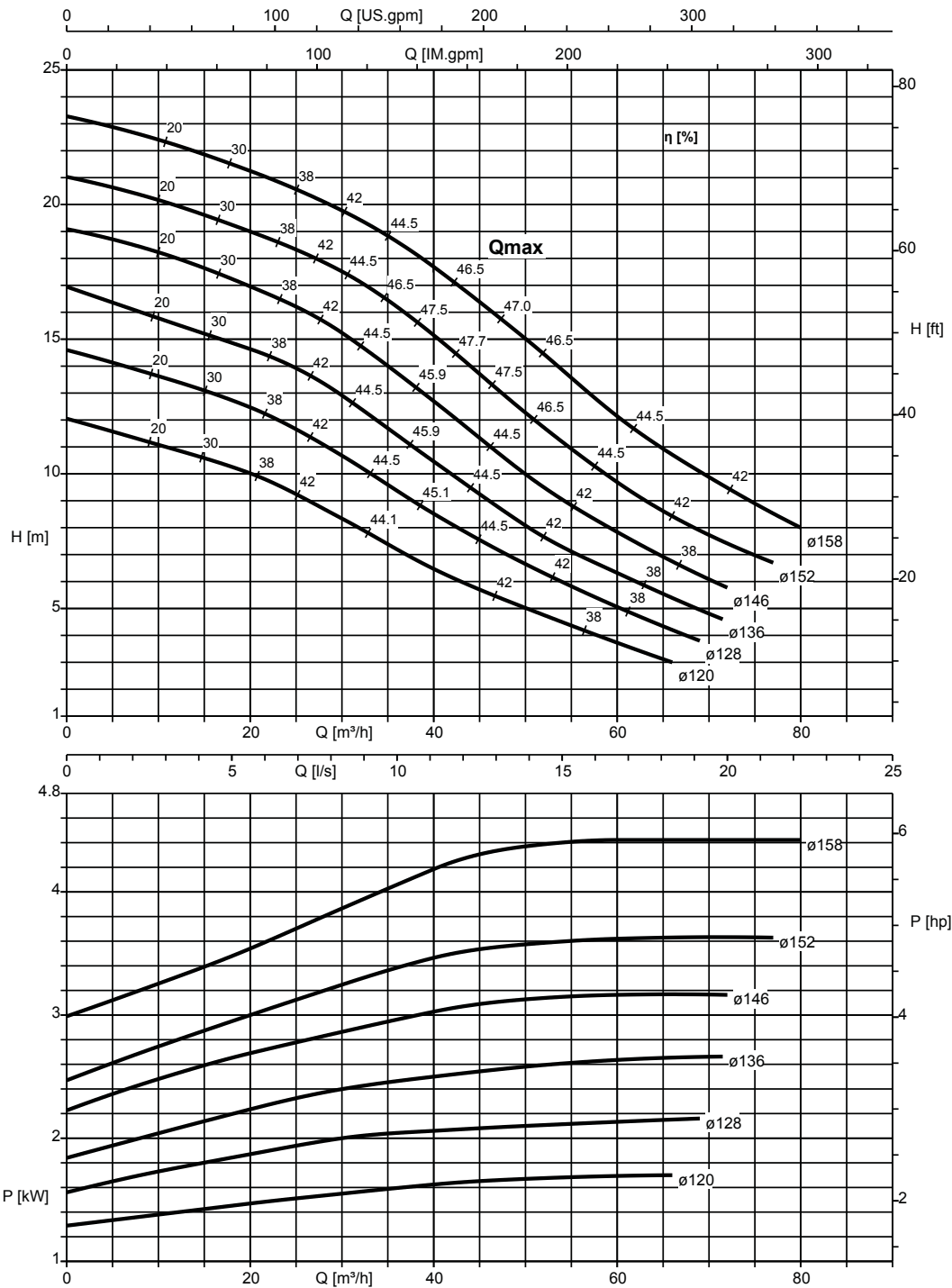

K2563-52-05/0

Free passage = 65 mm

n = 1450 rpm

**Amarex N F 65-220, n = 1450 rpm**

Characteristic curves to ISO 9906 Class 2A / 3B, below 10 kW to § 4.4.2. They refer to the effective motor speed.

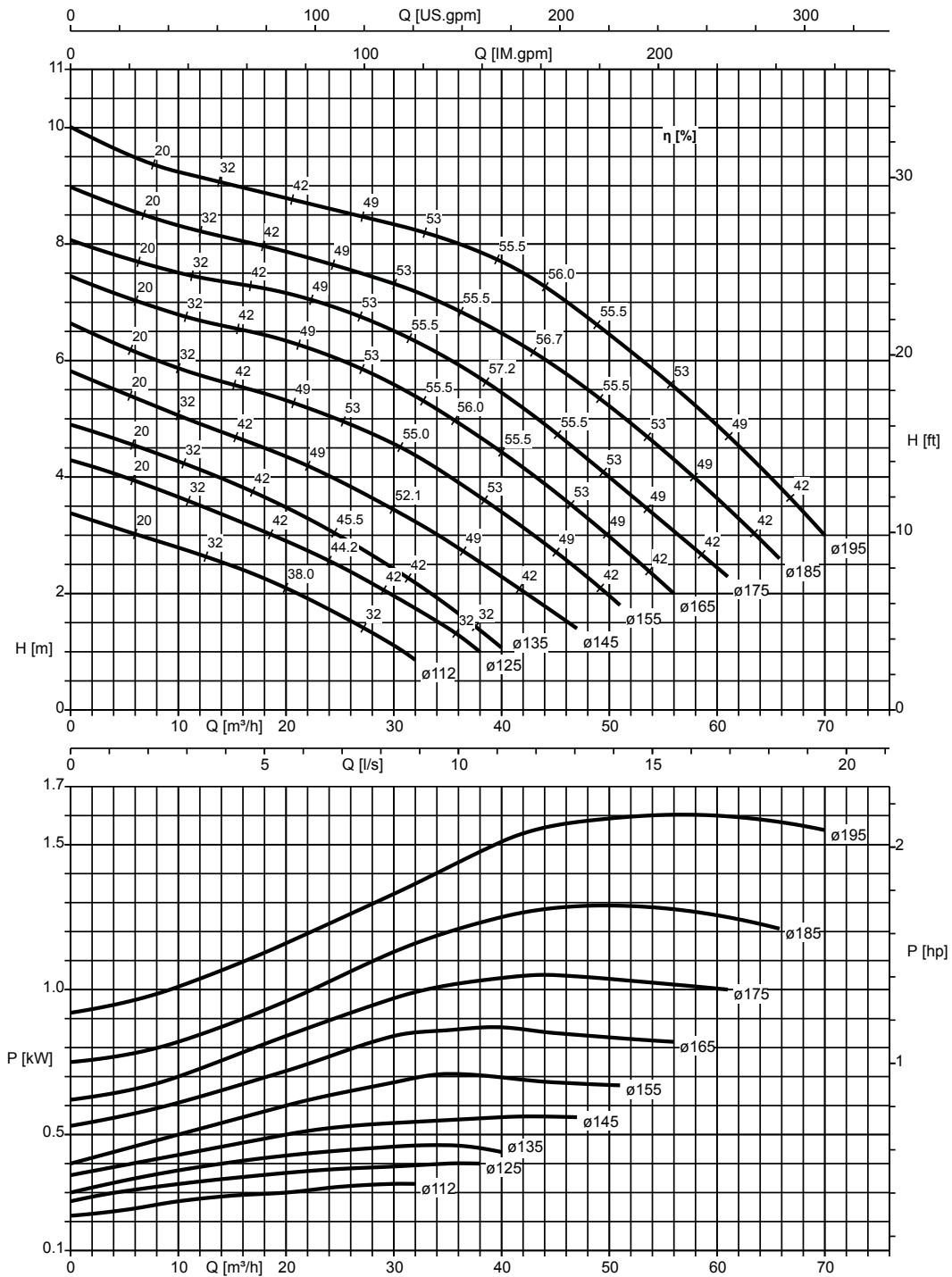

K2563-54-06/0

Free passage = 65 mm

**Amarex N F 80-220, n = 1450 rpm**

Characteristic curves to ISO 9906 Class 2A / 3B, below 10 kW to § 4.4.2. They refer to the effective motor speed.

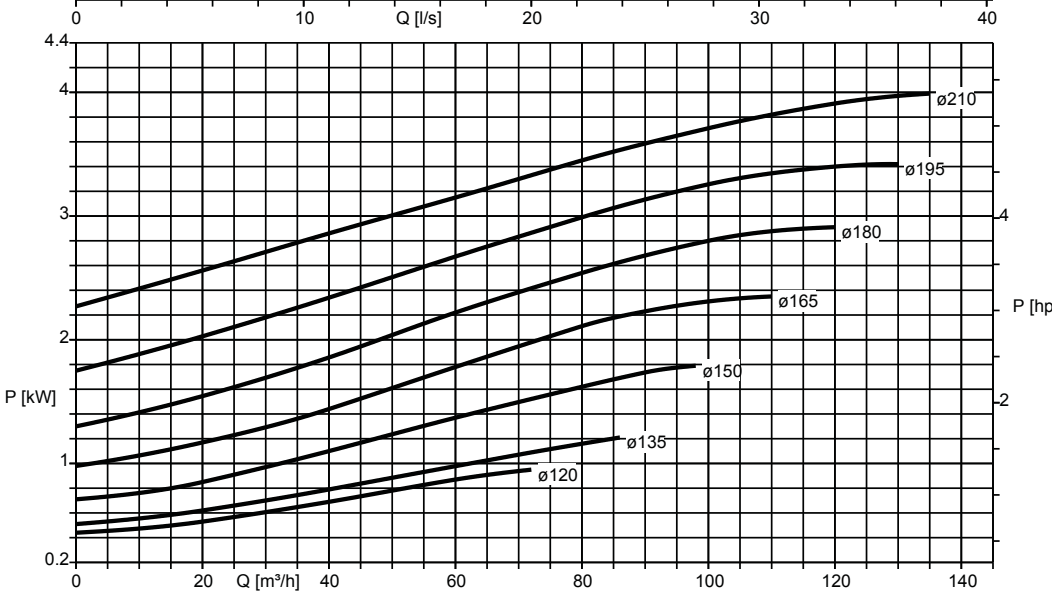
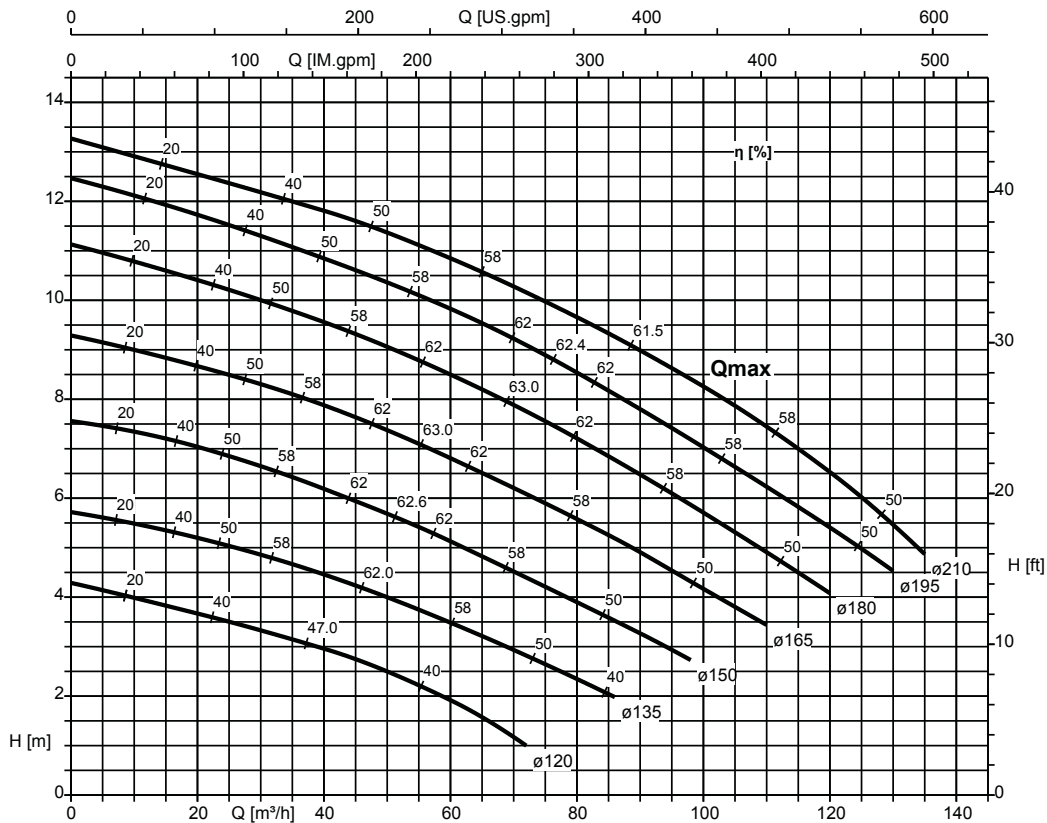

K2563-54-07/0

Free passage = 76 mm

**Amarex N F 100-220, n = 1450 rpm**

Characteristic curves to ISO 9906 Class 2A / 3B, below 10 kW to § 4.4.2. They refer to the effective motor speed.

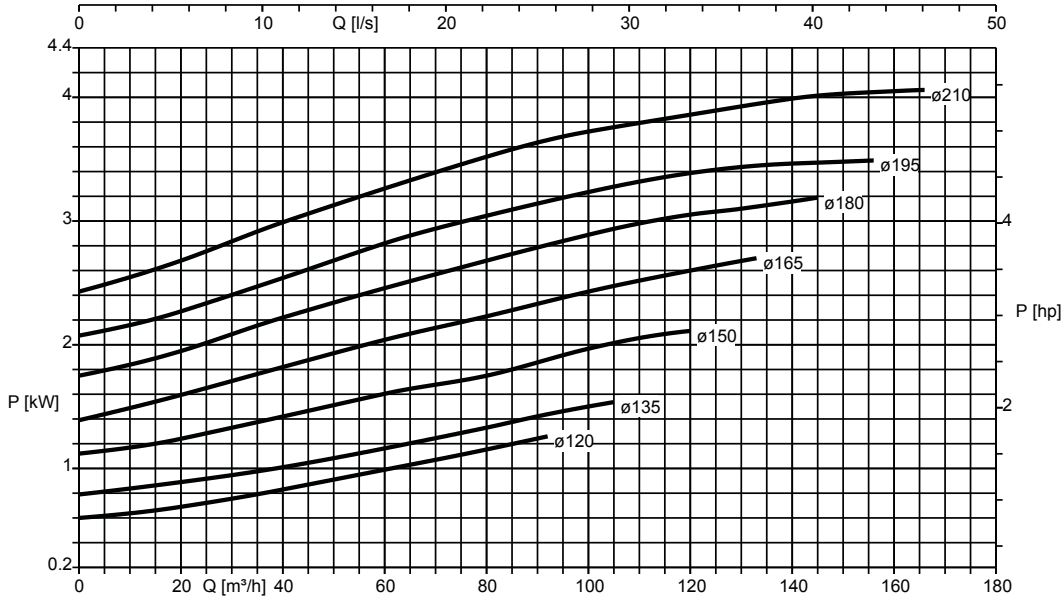
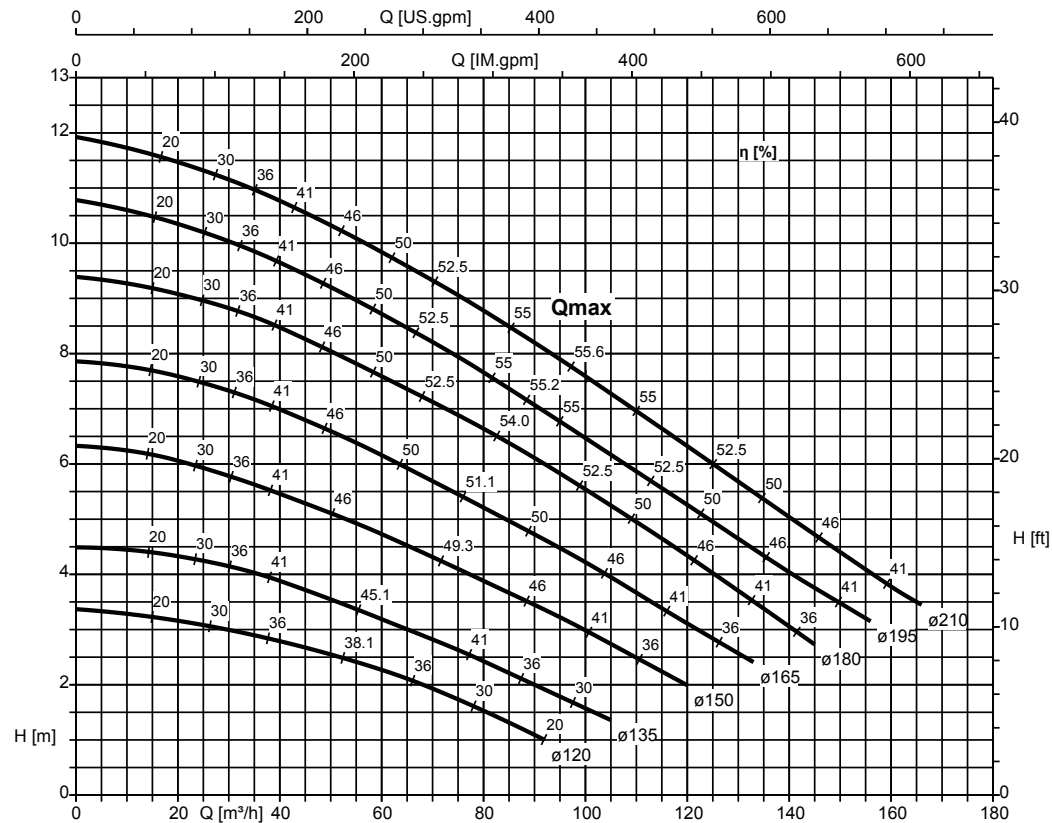

K2563-54-08/0

Free passage = 100 mm

**Amarex N D 80-220, n = 1450 rpm**

Characteristic curves to ISO 9906 Class 2A / 3B, below 10 kW to § 4.4.2. They refer to the effective motor speed.

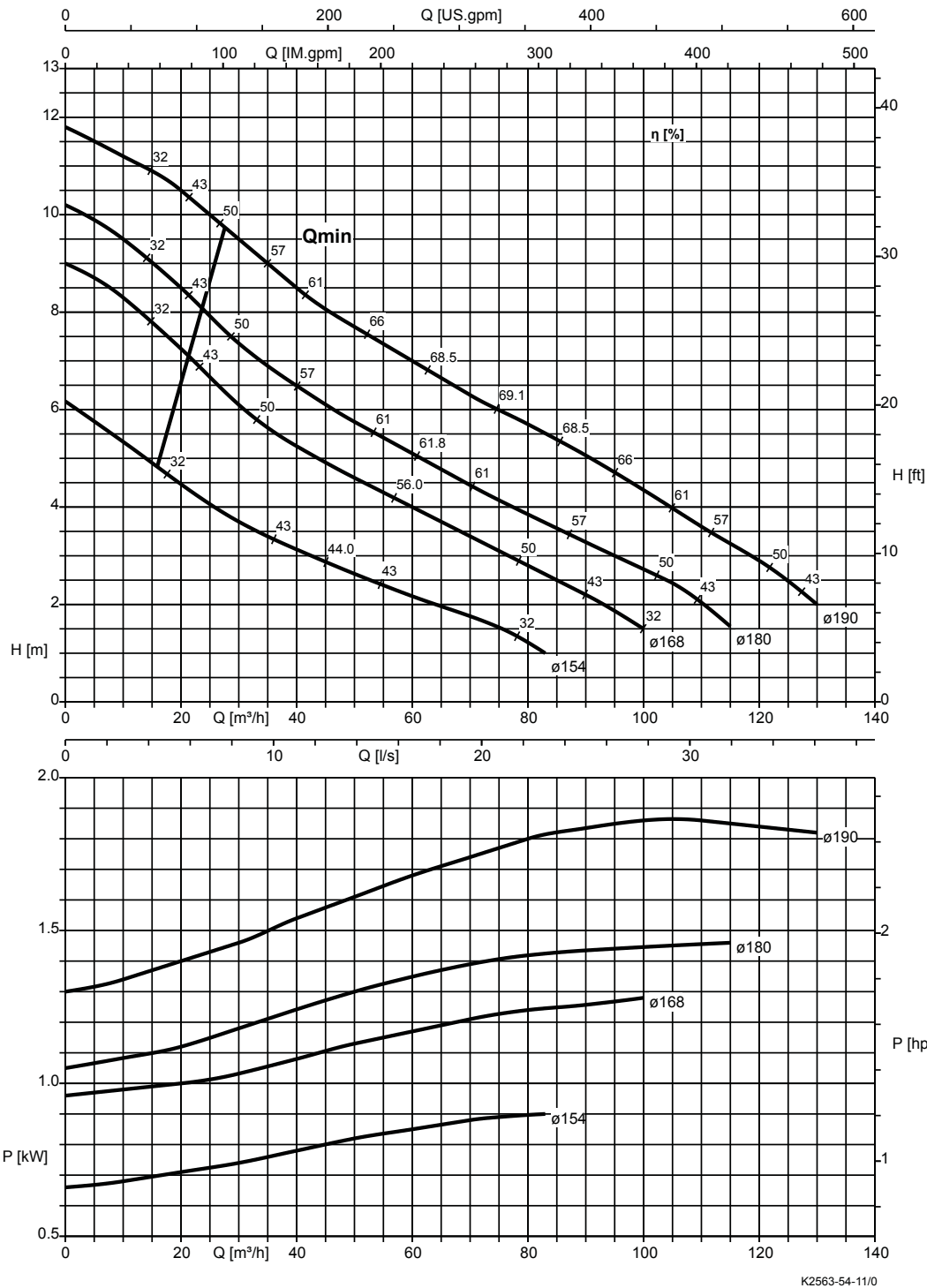

Free passage = 65 mm

**Amarex N D 100-220, n = 1450 rpm**

Characteristic curves to ISO 9906 Class 2A / 3B, below 10 kW to § 4.4.2. They refer to the effective motor speed.

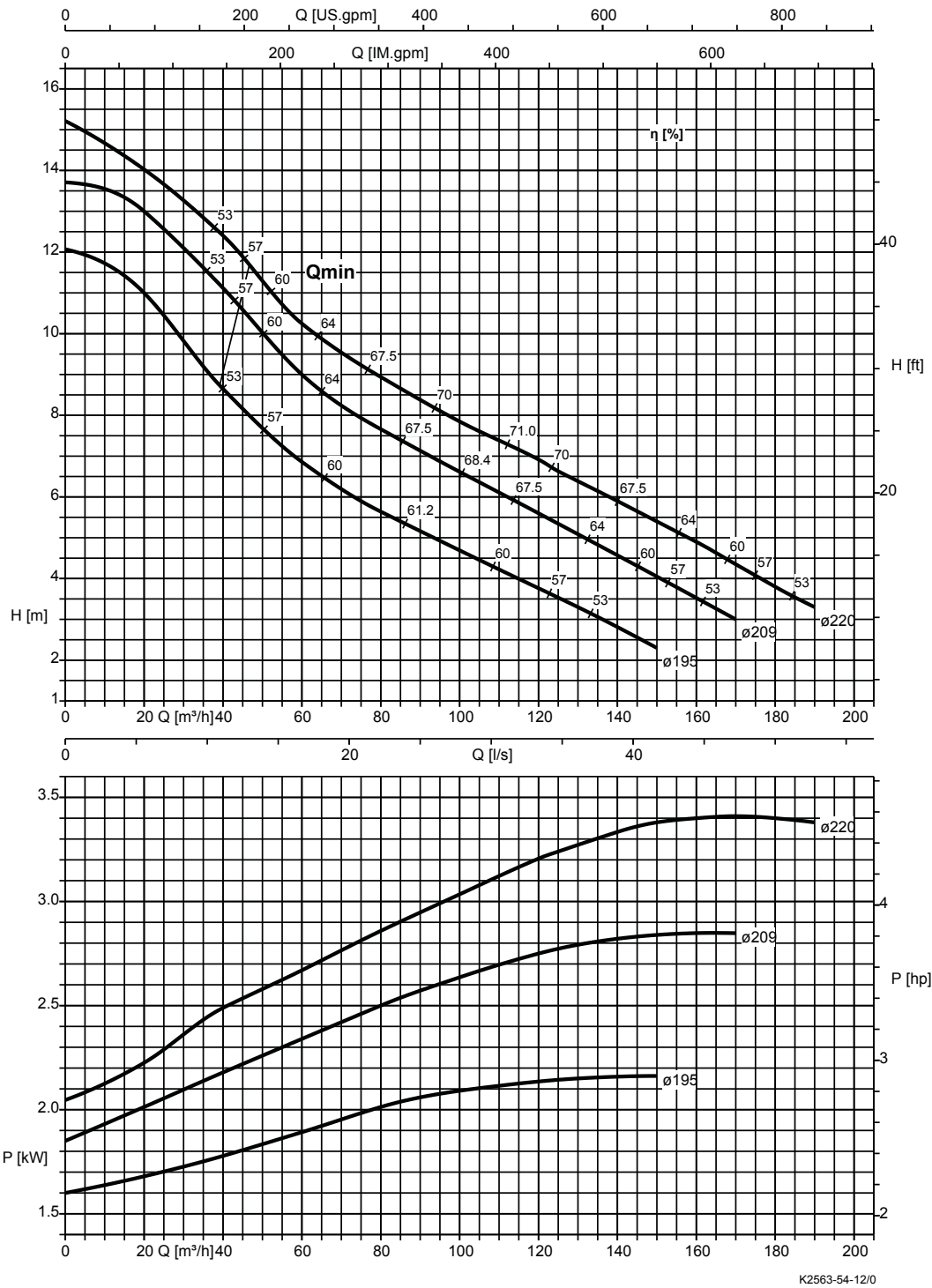

Free passage = 76 mm

## Dimensions and connections

### Connections

Discharge line connections at the duckfoot bend

Flanged connection (DN 50/DN 65)	Threaded connection in the flange (DN 50/DN 65)	Clamped connection (DN 50/DN 65)
	<p>For standard pipes to DIN 2440 / DIN 2441</p> <ul style="list-style-type: none"> <li>▪ With outside diameter of 60.3 mm, steel for DN 50</li> <li>▪ With outside diameter of 63 mm, PVC (ISO 3606) for DN 50</li> <li>▪ With threaded flange DN 50 - G 2"</li> <li>▪ With outside diameter of 76.1 mm, steel for DN 65</li> <li>▪ With outside diameter of 75 mm, PVC (ISO 3606) for DN 65</li> <li>▪ With threaded flange DN 65 - G 2 1/2"</li> </ul>	<p>For standard pipes to DIN 2440 / DIN 2441 / DIN 2448</p> <ul style="list-style-type: none"> <li>▪ With outside diameter of 60.3 mm, steel for DN 50</li> <li>▪ With outside diameter of 63 mm, PVC (ISO 3606) for DN 50</li> <li>▪ With outside diameter of 76.1 mm, steel for DN 65</li> <li>▪ With outside diameter of 75 mm, PVC (ISO 3606) for DN 65</li> </ul>

Dimensions

Amarex N 50/65/80/100 - transportable version

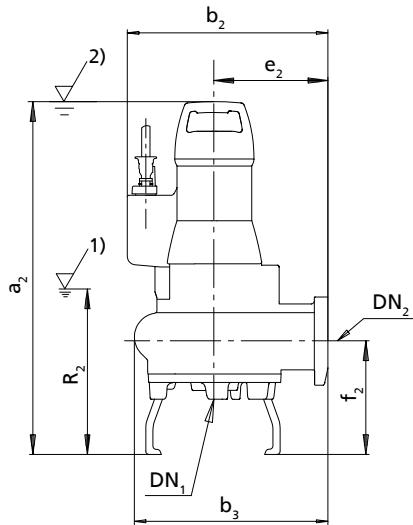

- 1) Lowest switch-off point for automatic operation
- 2) Minimum submergence for continuous operation

Pump dimensions [mm]

Size	Pump							
	DN <sub>1</sub>	DN <sub>2</sub>	a <sub>2</sub> <sup>18)</sup>	b <sub>2</sub>	b <sub>3</sub>	e <sub>2</sub>	f <sub>2</sub> <sup>18)</sup>	R <sub>2</sub>
50-172 S	-	50	547	322	293	180	152	207
50-170 F	50	50	547	322	293	180	152	207
50-222 S	-	50	609	336	307	180	155	203
50-220 F	50	50	609	336	307	180	155	203
65-170 F	65	65	653	367	338	210	164	248
65-220 F	65	65	593	353	347	210	163	253
80-220 F	80	80	672	386	392	230	187	249
80-220 D	-	80	672	386	392	230	187	249
100-220 F	100	100	698	383	390	230	207	277
100-220 D	-	100	698	383	390	230	207	277

Connection elbow with flange/hose connection (P13)

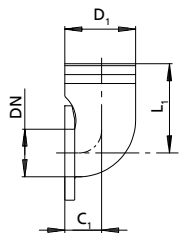

Dimensions [mm]

DN	D <sub>1</sub>	C <sub>1</sub>	L <sub>1</sub>
65	75	40	135
80	75	115	175
100	110	45	195

Connection elbow with flanges (P14)

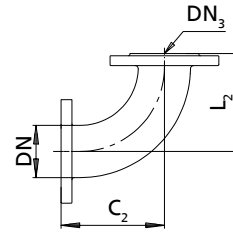

Dimensions [mm]

DN	DN <sub>3</sub> <sup>19)</sup>	C <sub>2</sub>	L <sub>2</sub>
65	65	135	135
80	80	135	135
100	100	120	175

Connection elbow with internal and external thread (P14) and threaded flange (P27)

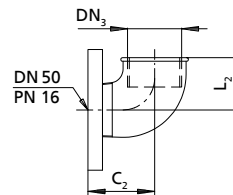

Dimensions [mm]

DN	DN <sub>3</sub>	C <sub>2</sub>	L <sub>2</sub>
50	G 2"	78	58

Pump flange DN<sub>2</sub>

DN 50 and 65  
ISO 7005 PN 16  
DIN 2501 PN 16

DN 80 and 100  
ISO 7005 PN16  
DIN 2501 PN16

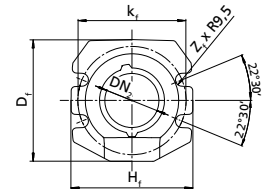
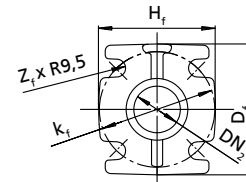

Dimensions of the pump flange in [mm]

Size	Flange			
	H <sub>f</sub>	k <sub>f</sub>	D <sub>f</sub>	Z <sub>f</sub>
50-172 S	125	125	140	4
50-170 F	125	125	140	4
50-222 S	125	125	140	4
50-220 F	125	125	140	4
65-170 F	144	145	164	4
65-220 F	144	145	164	4
80-220 F	180	160	180	4
80-220 D	180	160	180	4
100-220 F	202	180	205	4
100-220 D	202	180	205	4

<sup>18)</sup> If a foot plate is fitted, a<sub>2</sub> + 10 mm

<sup>19)</sup> DN<sub>3</sub> to ISO 7005/DIN 2501



**Amarex N 50 - stationary installation with guide wire, single guide rail and guide hoop arrangement, straight claw**

DN 3 = DN 50: DIN ISO ASME = standard

**Guide wire arrangement**

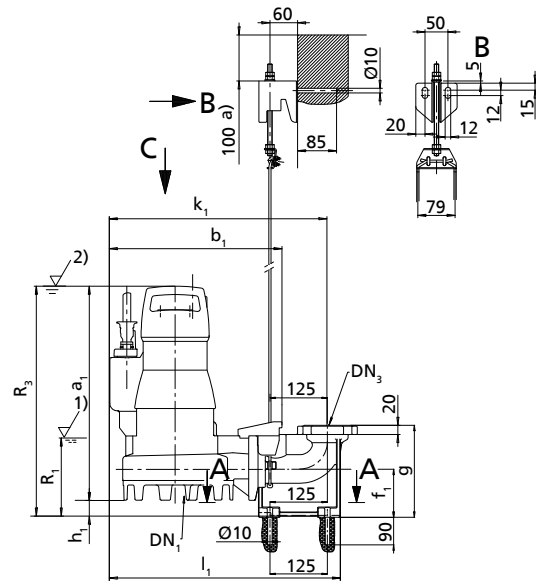

**Single guide rail arrangement**

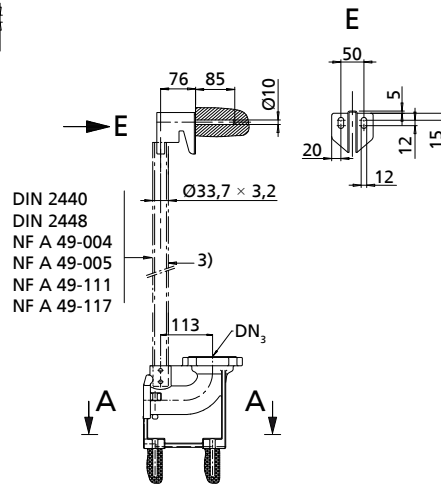

**Guide hoop arrangement**

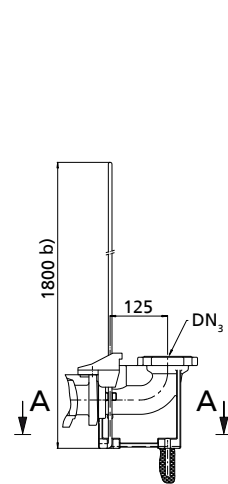

1)	Lowest switch-off point for automatic operation	2)	Minimum submergence for continuous operation
3)	Not included in KSB's scope of supply	a)	Minimum
b)	Maximum		

Dimensions of pump and foundation [mm]

Size	Pump													Foundation				
	DN <sub>1</sub>	DN <sub>2</sub>	a <sub>1</sub>	b <sub>1</sub>	d	f <sub>1</sub>	g	h <sub>1</sub>	k <sub>1</sub>	l <sub>1</sub>	m	R <sub>1</sub>	R <sub>3</sub>	Z <sub>f</sub>	DN <sub>3</sub>	N	O	P
50-172 S	-	50	470	376	250	105	200	31	472	502	125	161	501	4	50	465	465	350
50-170 F	50	50	470	376	250	105	200	31	472	502	125	161	501	4	50	465	465	350
50-222 S	-	50	532	389	254	105	200	27	488	514	129	153	559	4	50	465	465	350
50-220 F	50	50	532	389	254	105	200	27	488	514	129	153	559	4	50	465	465	350

**Installation in the sump**

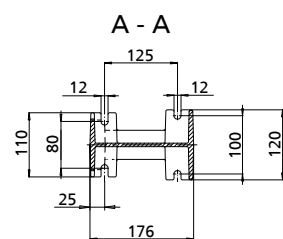

**Pump flange DN<sub>2</sub>**  
ISO 7005 PN 10/16  
DIN 2501 PN 10/16

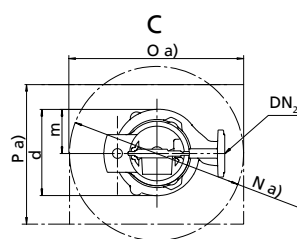

**Flanged bend DN<sub>3</sub>**  
ISO 7005 PN 10 - PN 16  
DIN 2501 PN 10 - PN 16  
ASME 2"  
ASME B16.1 class 125

**Clamped connection**

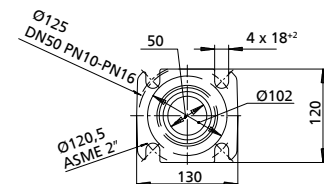
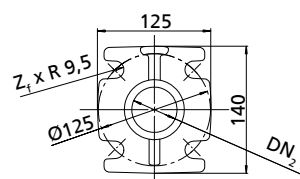
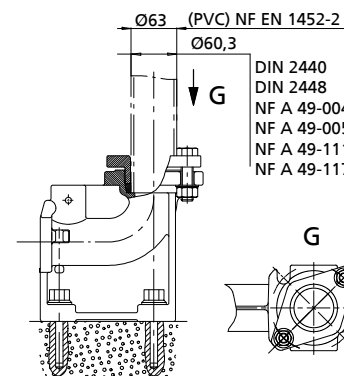

**Amarex N 50 - stationary installation with guide wire, single guide rail and guide hoop arrangement, inclined claw**

DN 3 = DN 50: DIN ISO ASME = standard

**Guide wire arrangement**

**Single guide rail arrangement**

**Guide hoop arrangement**

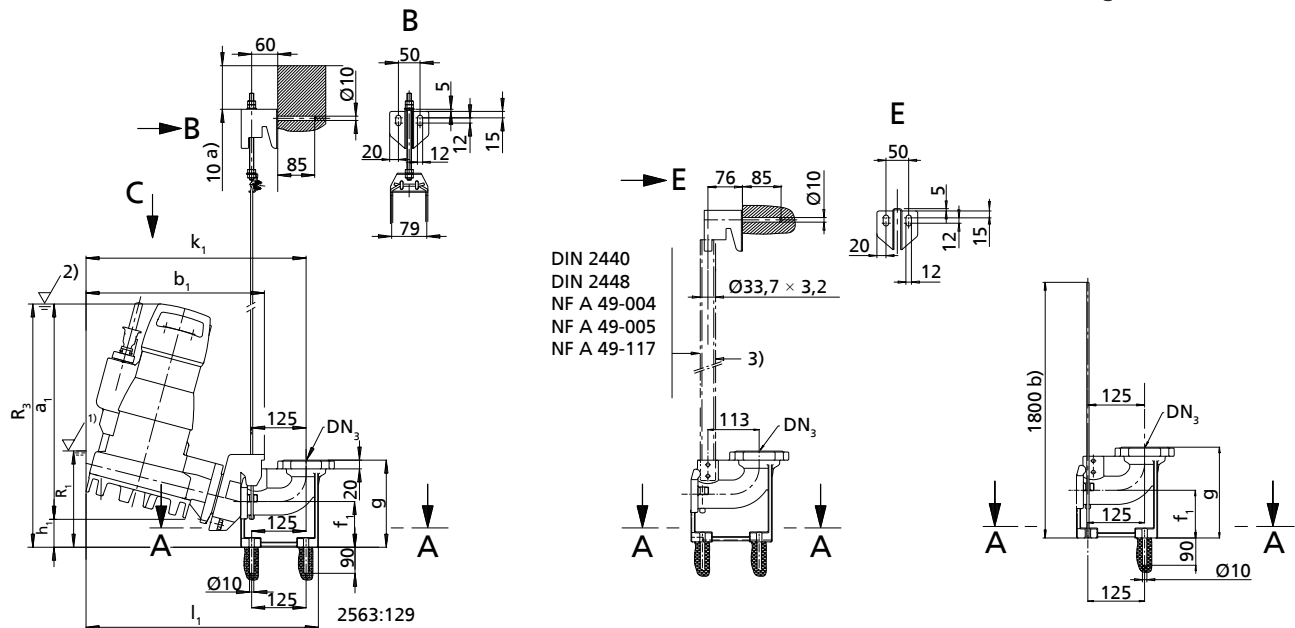

1)	Lowest switch-off point for automatic operation	2)	Minimum submergence for continuous operation
3)	Not included in KSB's scope of supply	a)	Minimum
b)	Maximum		

Dimensions of pump and foundation [mm]

Size	Pump													Foundation			
	DN <sub>2</sub>	a <sub>1</sub>	b <sub>1</sub>	d	f <sub>1</sub>	g	h <sub>1</sub>	k <sub>1</sub>	l <sub>1</sub>	m	R <sub>1</sub>	R <sub>3</sub>	Z <sub>f</sub>	DN <sub>3</sub>	N	O	P
50-172 S	50	495	421	250	105	200	58	500	526	125	220	550	4	50	480	480	350
50-222 S	50	556	416	254	105	200	54	506	532	129	230	606	4	50	480	480	350

**Installation in the sump**

**Clamped connection**

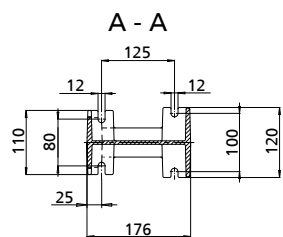

**Pump flange DN<sub>2</sub>**  
ISO 7005 PN10/16  
DIN 2501 PN10/16

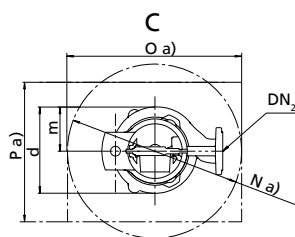

**Flanged bend DN<sub>3</sub>**  
ISO 7005 PN16  
DIN 2501 PN16  
ASME 2"  
ASME B16.1 class 125

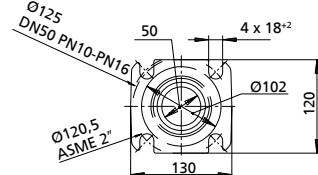
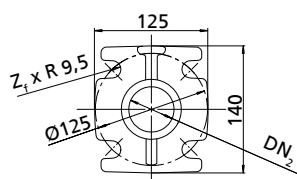
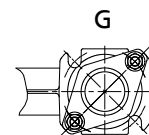
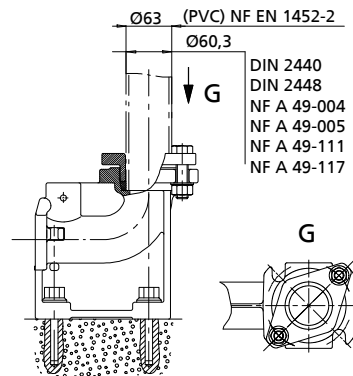

**Amarex N 50 - stationary installation with twin guide rail arrangement, inclined claw**

DN 3 = DN 50: DIN ISO ASME = standard

**Twin guide rail arrangement**

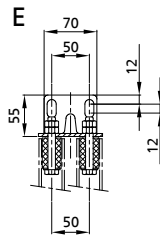
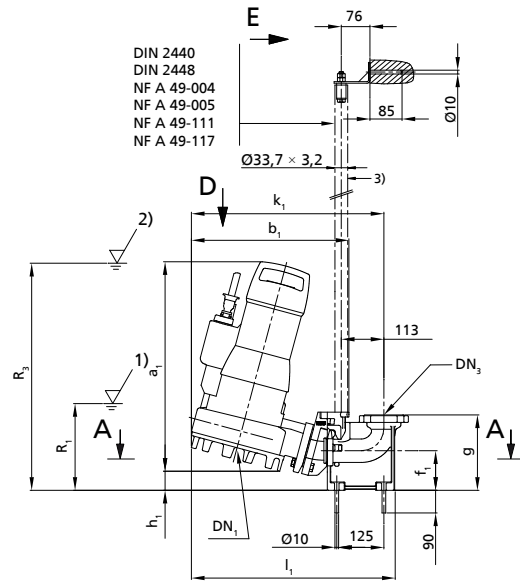

1)	Lowest switch-off point for automatic operation	2)	Minimum submergence for continuous operation
3)	Not included in KSB's scope of supply	a)	Minimum

Dimensions of pump and foundation [mm]

Size	Pump														Foundation			
	DN <sub>1</sub>	DN <sub>2</sub>	a <sub>1</sub>	b <sub>1</sub>	d	f <sub>1</sub>	g	h <sub>1</sub>	k <sub>1</sub>	l <sub>1</sub>	m	R <sub>1</sub>	R <sub>3</sub>	Z <sub>f</sub>	DN <sub>3</sub>	N	O	P
50-172 S	-	50	494	422	250	105	200	54	499	528	125	220	550	4	50	480	480	350
50-170 F	50	50	494	422	250	105	200	54	499	528	125	220	550	4	50	480	480	350
50-222 S	-	50	549	426	254	105	200	53	506	535	129	230	606	4	50	480	480	350
50-220 F	50	50	549	426	254	105	200	53	506	535	129	230	606	4	50	480	480	350

**Installation in the sump**

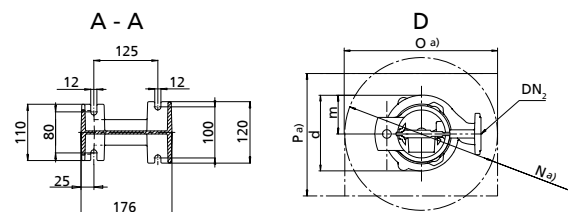

**Clamped connection**

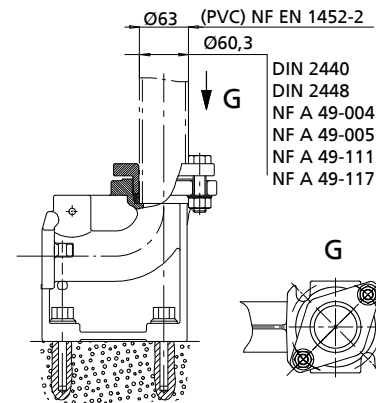

**Flanged bend DN<sub>3</sub>**

ISO 7005 PN16  
DIN 2501 PN16  
ASME 2"  
ASME B16.1 class 125

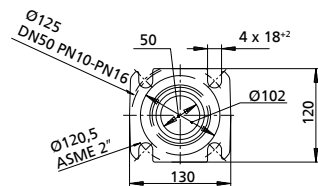

**Amarex N 65, stationary installation with guide wire, single guide rail and guide hoop arrangement**

DN 3 = 65/65: DIN ISO ASME = standard - DN 3 = 65/80: DIN ISO = standard, ASME = variant

**Guide wire arrangement**

**Single guide rail arrangement**

**Guide hoop arrangement**

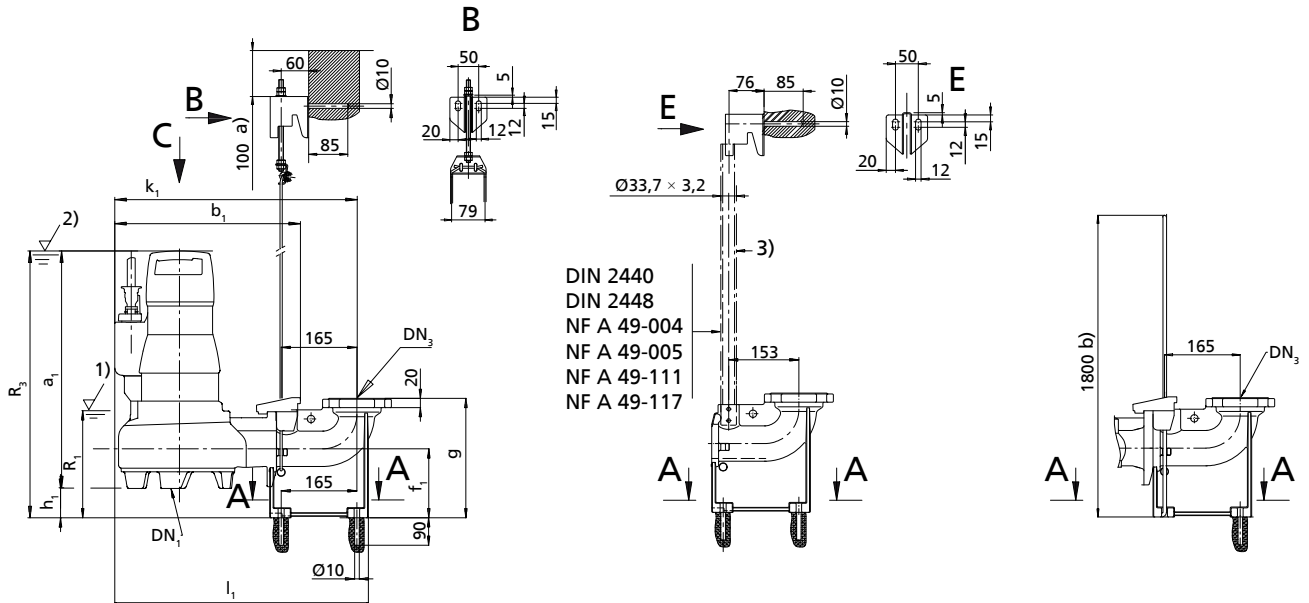

1)	Lowest switch-off point for automatic operation	2)	Minimum submergence for continuous operation
3)	Not included in KSB's scope of supply	a)	Minimum
b)	Maximum		

Dimensions of pump and foundation [mm]

Size	Pump														Foundation			
	DN <sub>1</sub>	DN <sub>2</sub>	a <sub>1</sub>	b <sub>1</sub>	d	f <sub>1</sub>	g	h <sub>1</sub>	k <sub>1</sub>	l <sub>1</sub>	m	R <sub>1</sub>	R <sub>3</sub>	Z <sub>f</sub>	DN <sub>3</sub>	N	O	P
65-170 F	65	65	578	422	251	150	260	61	558	583	127	234	639	4	65	500	500	400
65-220 F	65	65	518	407	265	150	260	63	544	569	142	241	581	4	65	500	500	400

**Installation in the sump**

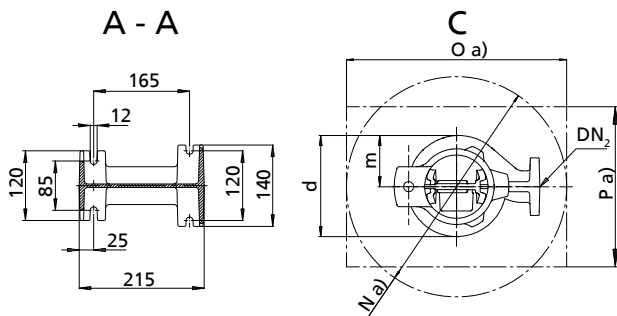

**Flanged bend DN**

**DN 65/65**

ISO 7005 PN16  
DIN 2501 PN16

ASME B 16.1 class 125  
2 1/2"

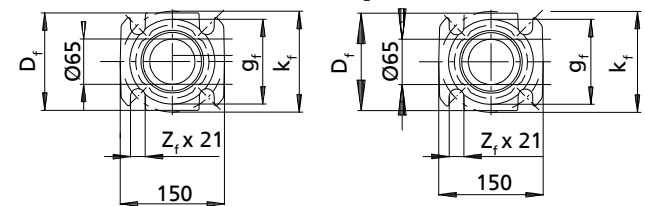

Dimensions of the flanged bend DN<sub>3</sub> [mm]

Flange variant	DN <sub>3</sub>	g <sub>f</sub>	k <sub>f</sub>	D <sub>f</sub>	Z <sub>f</sub>
ISO 7005 PN16	65	122	145	140	4
DIN 2501 PN16	80	133	160	200	8
ASME B16.1 class 125	65	122	140	140	4
	80	127	152,5	191	4

Extension elbow DN<sub>3</sub>

DN 65/80

ISO 7005 PN16  
DIN 2501 PN16

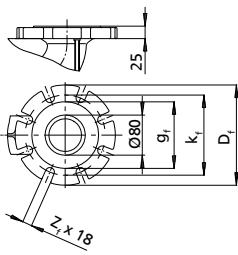

ASME B 16.1 class 125  
3"

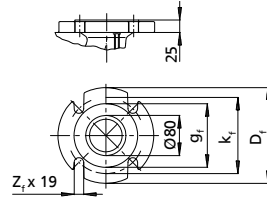

Clamped connection

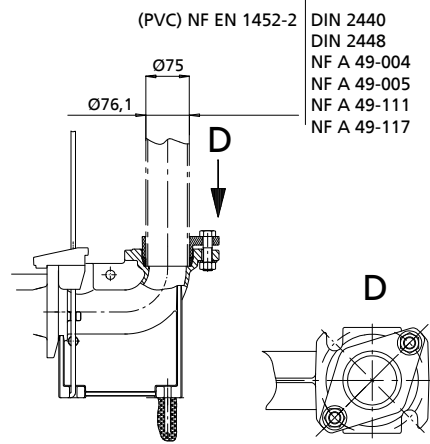

**Amarex N 65, stationary installation with twin guide rail arrangement**

DN 3 = 65/65: DIN ISO ASME = standard - DN 3 = 65/80: DIN ISO = standard, ASME = variant

**Twin guide rail arrangement**

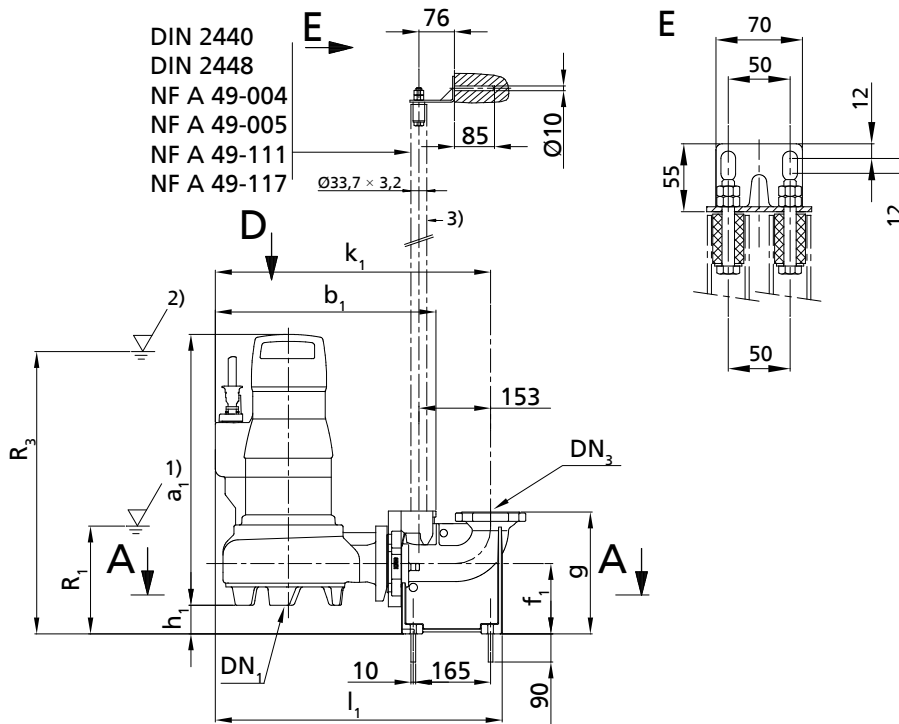

1)	Lowest switch-off point for automatic operation	2)	Minimum submergence for continuous operation
3)	Not included in KSB's scope of supply	a)	Minimum

Dimensions of pump and foundation [mm]

Size	Pump													Foundation			
	DN <sub>1</sub>	DN <sub>2</sub>	a <sub>1</sub>	b <sub>1</sub>	d	f <sub>1</sub>	g	h <sub>1</sub>	k <sub>1</sub>	l <sub>1</sub>	m	R <sub>1</sub>	R <sub>3</sub>	Z <sub>f</sub>	N	O	P
65-170 F	65	65	578	468	251	150	260	61	588	613	127	234	639	4	550	550	400
65-220 F	65	65	518	454	265	150	260	63	574	599	142	241	581	4	550	550	400

**Installation in the sump**

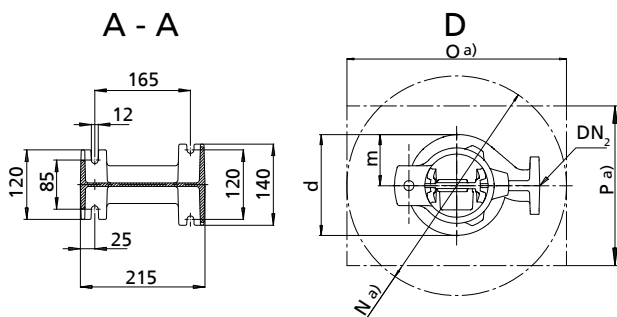

**Flanged bend DN**

**DN 65/65**

ISO 7005 PN16  
DIN 2501 PN16

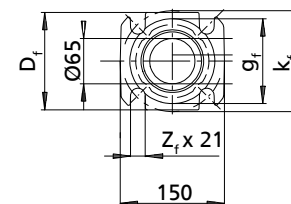

ASME B16.1 class 125  
2 1/2"

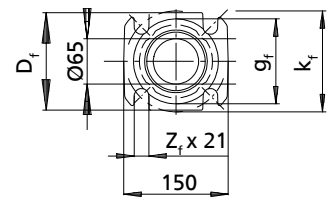

Dimensions of flanged bend DN<sub>3</sub> [mm]

Flange variant	DN <sub>3</sub>	g <sub>f</sub>	k <sub>f</sub>	D <sub>f</sub>	Z <sub>f</sub>
ISO 7005 PN16	65	122	145	140	4
DIN 2501 PN16	80	133	160	200	8
ASME B16.1 class 125	65	122	140	140	4
	80	127	152,5	191	4

**Extension elbow DN<sub>3</sub>**

**DN 65/80**

ISO 7005 PN16  
DIN 2501 PN16

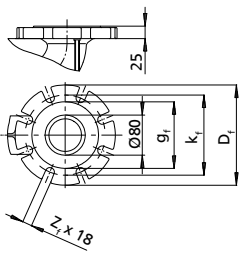

ASME B16.1 class 125  
3"

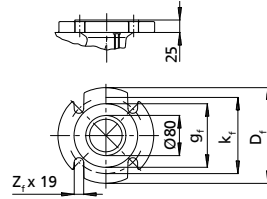

**Clamped connection**

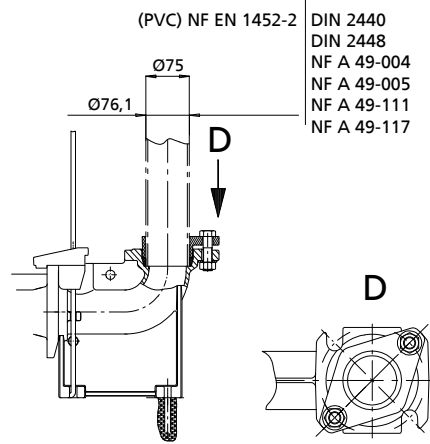

**Amarex N 80 and 100 - stationary installation with guide wire and single guide rail arrangement**

DN 3 = 80/80: DIN ISO = standard, ASME = variant - DN 3 = 80/100 or 100/100: DIN ISO ASME = standard

**Guide wire arrangement**

**Single guide rail arrangement**

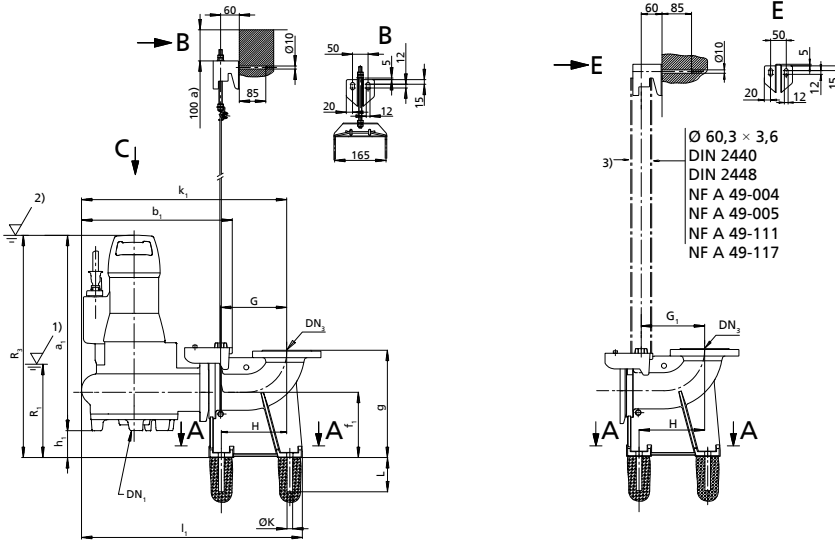

1)	Lowest switch-off point for automatic operation	2)	Minimum submergence for continuous operation
3)	Not included in KSB's scope of supply	a)	Minimum

**Pump dimensions [mm]**

Size	Pump													
	DN <sub>1</sub>	DN <sub>2</sub>	a <sub>1</sub>	b <sub>1</sub>	d	f <sub>1</sub>	g	h <sub>1</sub>	k <sub>1</sub>	l <sub>1</sub>	m	R <sub>1</sub>	R <sub>3</sub>	
80-220 F	80	80	582	478	322	200	320	103	604	694	176	262	685	
80-220 D	-	80	602	478	322	200	320	86	604	694	176	262	688	
100-220 F	100	100	603	476	318	210	345	98	641	691	169	280	701	
100-220 D	-	100	628	476	318	210	345	76	641	691	169	280	704	

**Foundation dimensions [mm]**

Size	Foundation														
	DN <sub>3</sub>	A	B	C	D	E	G	G <sub>1</sub>	H	J	øK	L	N	O	P
80-220 F/D	80	300	200	220	150	40	172,5	163	170	20	18	110	550	550	400
80-220 F/D	100	300	200	220	150	40	172,5	163	170	20	18	110	550	550	400
100-220 F/D	100	300	200	220	150	40	212,5	203	210	20	18	110	550	550	400

**Installation in the sump**

**Flanged bend DN**

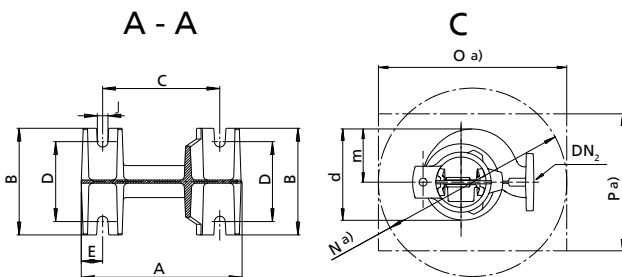

**DN 80/80**  
ISO 7005 PN16  
DIN 2501 PN16  
**DN 100/100**  
ISO 7005 PN16  
DIN 2501 PN16  
ASME B16.1 class 125  
4"

**DN 80/80**  
ASME B16.1 class 125  
3"

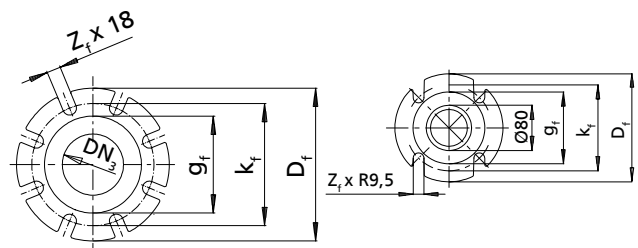



**Extension elbow DN<sub>3</sub>**

**DN 80/100**  
ISO 7005 PN16  
DIN 2501 PN16

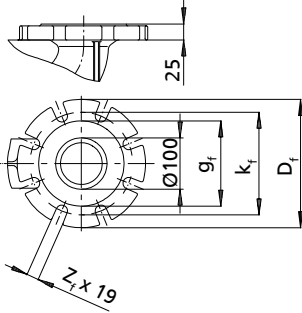

**DN 80/100**  
ASME B16.1 class 125  
4"

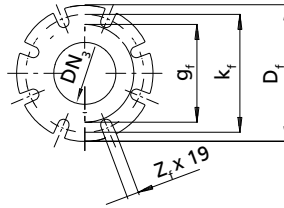

Dimensions of flanged bend DN<sub>3</sub> [mm]

Flange variant	DN <sub>3</sub>	g <sub>f</sub>	k <sub>f</sub>	D <sub>f</sub>	Z <sub>f</sub>
ISO 7005 PN16	80	132	160	200	8
DIN 2501 PN16	100	156	180	220	8
ASME B16.1 class 125	80	127	152,5	191	4
	100	156	190,5	220	8

### Amarex N 80 and 100 - stationary installation with twin guide rail arrangement

DN 3 = 80/80: DIN ISO = standard, ASME = variant - DN 3 = 80/100 or 100/100: DIN ISO ASME = standard

#### Twin guide rail arrangement

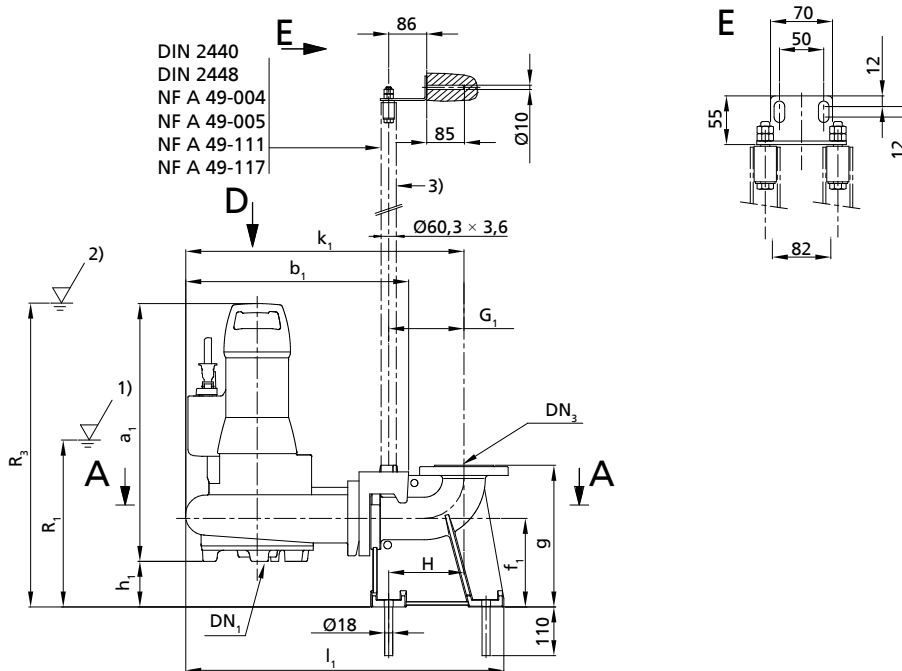

1)	Lowest switch-off point for automatic operation	2)	Minimum submergence for continuous operation
3)	Not included in KSB's scope of supply	a)	Minimum
b)	Maximum		

#### Pump dimensions [mm]

Size	Pump												
	DN <sub>1</sub>	DN <sub>2</sub>	a <sub>1</sub>	b <sub>1</sub>	d	f <sub>1</sub>	g	h <sub>1</sub>	k <sub>1</sub>	l <sub>1</sub>	m	R <sub>1</sub>	R <sub>3</sub>
80-220 F	80	80	582	506	322	200	320	103	630	720	176	262	685
80-220 D	-	80	602	506	322	200	320	86	630	720	176	262	688
100-220 F	100	100	603	529	318	210	345	98	674	724	169	280	701
100-220 D	-	100	628	529	318	210	345	76	674	724	169	280	704

#### Installation in the sump

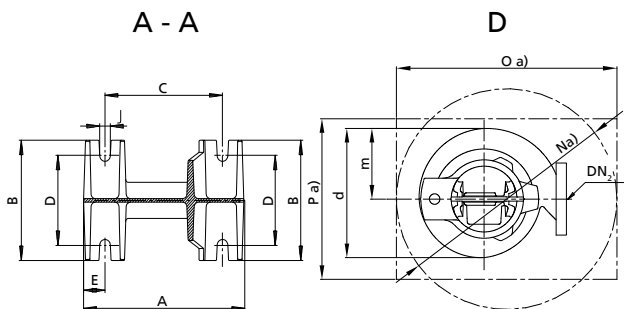

#### Foundation dimensions [mm]

Size	Foundation											
	DN <sub>3</sub>	A	B	C	D	E	G <sub>1</sub>	H	J	N	O	P
80-220 F	80	300	200	220	150	40	170	170	20	580	580	400
80-220 D	100	300	200	220	150	40	170	170	20	580	580	400
100-220 F	100	300	200	220	150	40	210	210	20	600	600	400
100-220 D	100	300	200	220	150	40	210	210	20	600	600	400

### Flanged bend DN

**DN 80/80**

ISO 7005 PN16  
DIN 2501 PN16

**DN 100/100**

ISO 7005 PN16  
DIN 2501 PN16  
ASME B16.1 class 125  
4"

**DN 80/80**

ASME B16.1 class 125  
3"

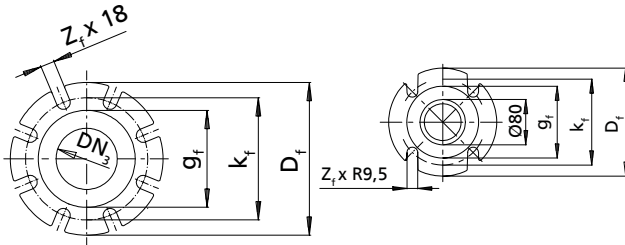

### Extension elbow DN<sub>3</sub>

**DN 80/80**

ISO 7005 PN16  
DIN 2501 PN16

**DN 80/100**

ASME B16.1 class 125  
4"

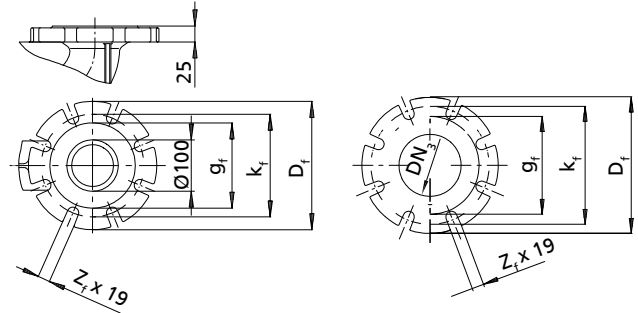

Dimensions of flanged bend DN<sub>3</sub> [mm]

Flange variant	DN <sub>3</sub>	g <sub>f</sub>	k <sub>f</sub>	D <sub>f</sub>	Z <sub>f</sub>
ISO 7005 PN16	80	132	160	200	8
DIN 2501 PN16	100	156	180	220	8
ASME B16.1 150 lbs	80	127	152,5	191	4
	100	156	190,5	220	8

**Installation types**

Installation type S – stationary wet installation

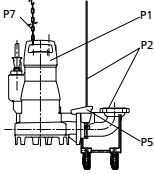
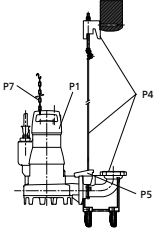
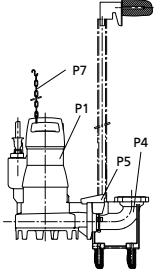
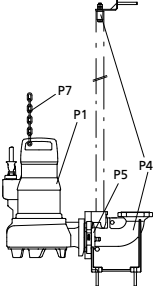
Installation type	Description	Comment
	<p><b>Guide hoop arrangement</b></p> <p>P1: pump</p> <p>P2: installation parts for guide hoop arrangement, installation depth = 1.5 m / 1.8 m / 2.1 m</p> <p>P5: claw</p> <p>P7: chain and shackle, length = 2 m</p>	<p>Only for the following sizes:</p> <p>50-170</p> <p>50-172</p> <p>50-220</p> <p>50-222</p> <p>65-170</p> <p>65-220</p>
	<p><b>Guide wire arrangement</b></p> <p>P1: pump</p> <p>P4: installation parts for guide wire arrangement, installation depth = 4.5 m</p> <p>P5: claw</p> <p>P7: chain and shackle, length = 5 m</p>	
	<p><b>Single guide rail arrangement</b></p> <p>P1: pump</p> <p>P4: installation parts for single guide rail arrangement</p> <p>P5: claw</p> <p>P7: chain and shackle, length = 5 m</p>	
	<p><b>Twin guide rail arrangement</b></p> <p>P1: pump</p> <p>P4: installation parts for twin guide rail arrangement</p> <p>P5: claw and adapter</p> <p>P7: chain and shackle, length = 5 m</p>	

Installation type P – transportable wet installation

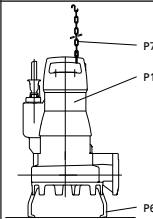
Installation type	Description
	<p>P1: pump</p> <p>P6: foot</p> <p>P7: chain and shackle, length = 5 m</p>

**Installation information**

**Suggested installation layouts for transportable pump sets**

Size 50

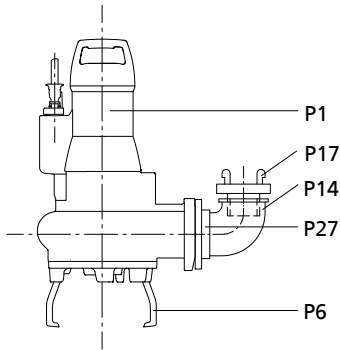

**Suggestion 1**

Vertical hose connection with elbow (P14) and Storz rigid coupling (P17) (quick connection)

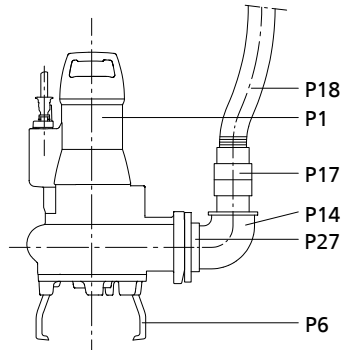

**Suggestion 2**

Vertical hose connection with plastic hose (P18)

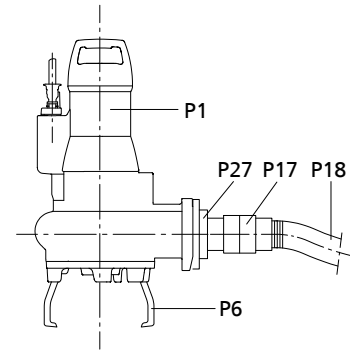

**Suggestion 3**

Horizontal hose connection (quick connection) with plastic hose (P18)

Sizes 65, 80, 100

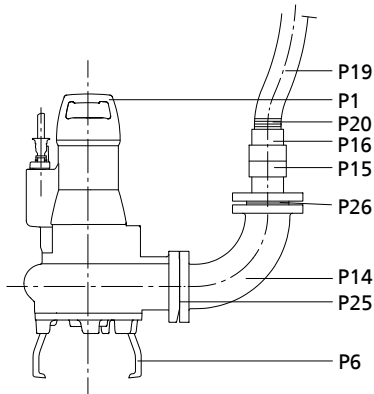

**Suggestion 1**

Vertical hose connection (quick connection) with plastic hose (P19) and hose clip (P20)

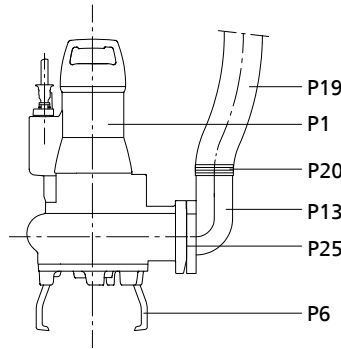

**Suggestion 2**

Vertical hose connection with plastic hose (P19), hose clip (P20) and connection elbow (P13)

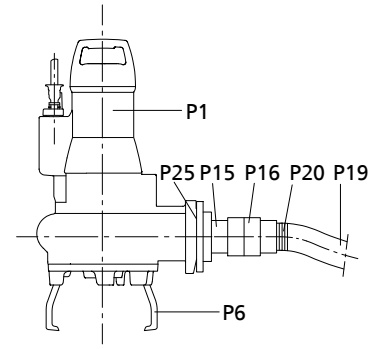

**Suggestion 3**

Horizontal hose connection (quick connection) with plastic hose (P19), hose clip (P20), Storz hose coupling (P16), Storz rigid coupling (P15)

P1 to P27 (⇒ Page 41)

**Suggested installation layouts for stationary pump sets**

Sizes 50, 65, 80, 100

**Guide hoop arrangement**

Amarex N S 50-172/F 50-170, S 50-222/F 50-220, F 65-170/65-220

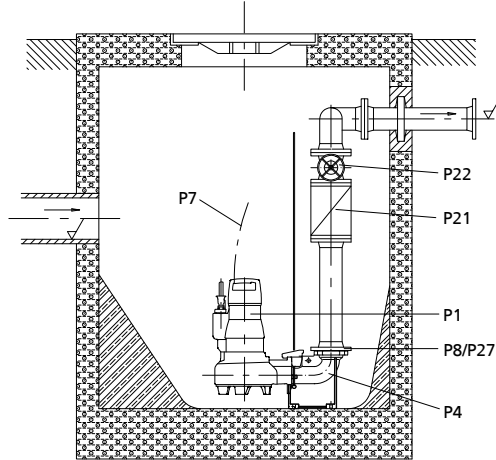

Suggestion 1  
Single-pump station  
Flanged duckfoot bend

**Suspended installation**

Amarex N S 50-172/F 50-170, S 50-222/F 50-220, F 65-170/65-220

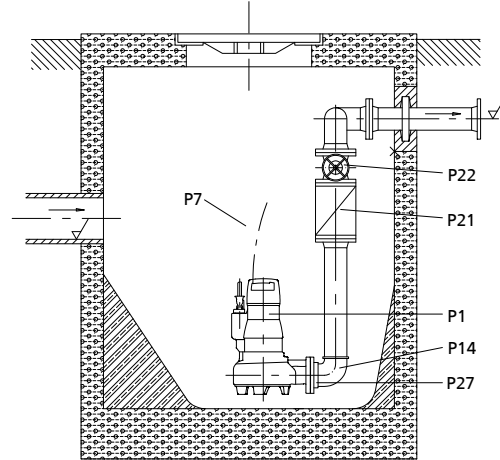

Suggestion 2  
Single-pump station for 1.5 m installation depth  
Direct connection to discharge pipe (suspended installation)

**Guide wire, single guide rail or twin guide rail arrangement**

Amarex N 50, 65, 80, 100

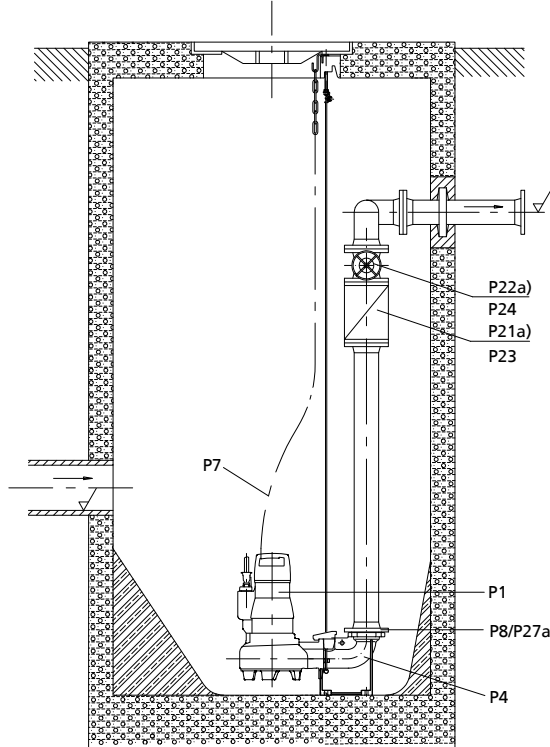

Suggestion 3  
Either with guide wire, single guide rail or twin guide rail arrangement  
Single-pump station for 4.5 m installation depth  
Flanged duckfoot bend

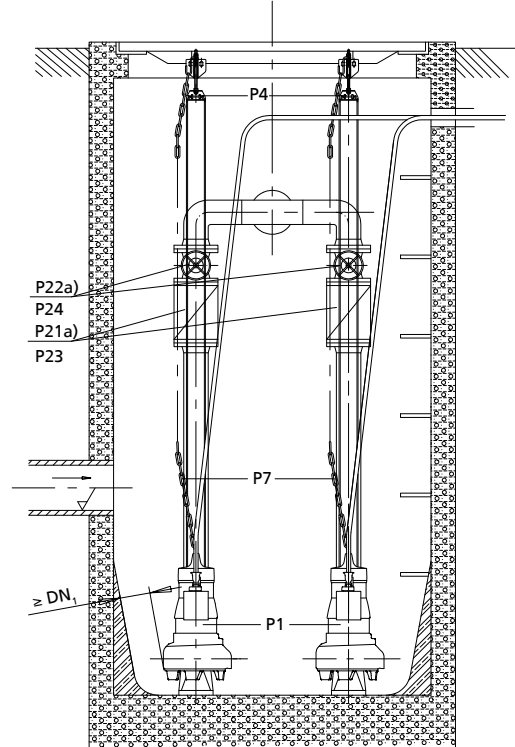

Suggestion 4  
Either with guide wire, single guide rail or twin guide rail arrangement  
Dual-pump station for 4.5 m installation depth  
Flanged duckfoot bend

a) DN 50 only

Dimensions

Guide wire arrangement

Amarex N 50, 65, 80, 100

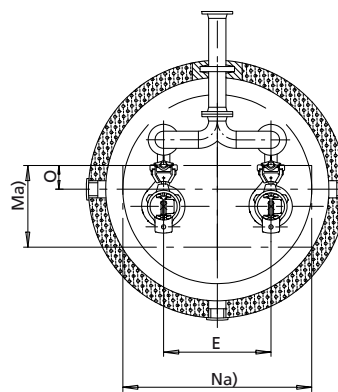
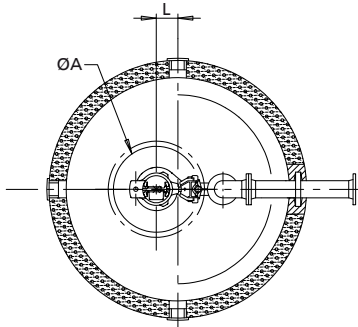
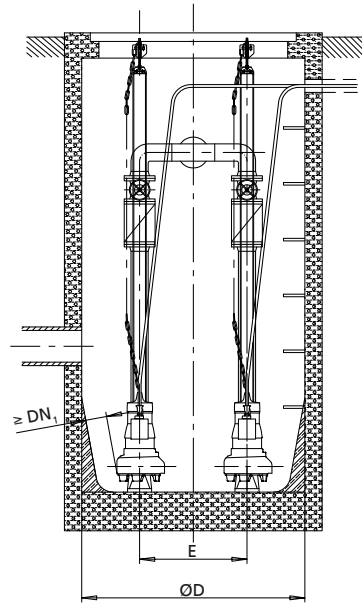
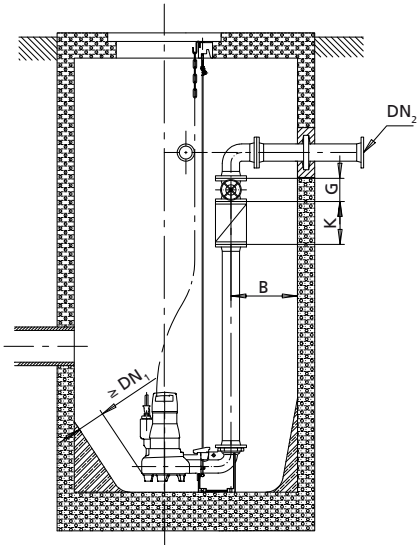

Single-pump station for 4.5 m installation depth  
Flanged duckfoot bend

Dual-pump station for 4.5 m installation depth  
Flanged duckfoot bend

a)	minimum
----	---------

Dimensions [mm]

Amarex N		Ø A	B	Ø D	E	G	K	L	M	N	O	DN <sub>1</sub>	DN <sub>2</sub>
S 50-172 /	1 pump	625	165	1000	-	75	150	42	-	-	-	50	50
F 50-170	2 pumps	-	235	1000	300	75	150	-	550	700	200	50	50
S 50-222 /	1 pump	625	165	1000	-	75	150	42	-	-	-	50	50
F 50-220	2 pumps	-	235	1000	300	75	150	-	550	700	200	50	50
F 65-170 /	1 pump	625	175	1000	-	180	260	92	-	-	-	65	65
F 65-220	2 pumps	-	360	1200	600	180	260	-	550	1000	135	65	65
F 80-220 /	1 pump	625	200	1000	-	180	260	25	-	-	-	80	80
D 80-220	2 pumps	-	320	1200	600	180	260	-	600	1000	168	80	80
F 100-220	1 pump	625	200	1000	-	190	300	65	-	-	-	100	100
	2 pumps	-	320	1200	600	190	300	-	600	1000	128	100	100

### Suggested electrical installation layouts

Amarex N is available in explosion-proof and non-explosionproof design.

CEE motor protection switch (up to 4.0 kW)

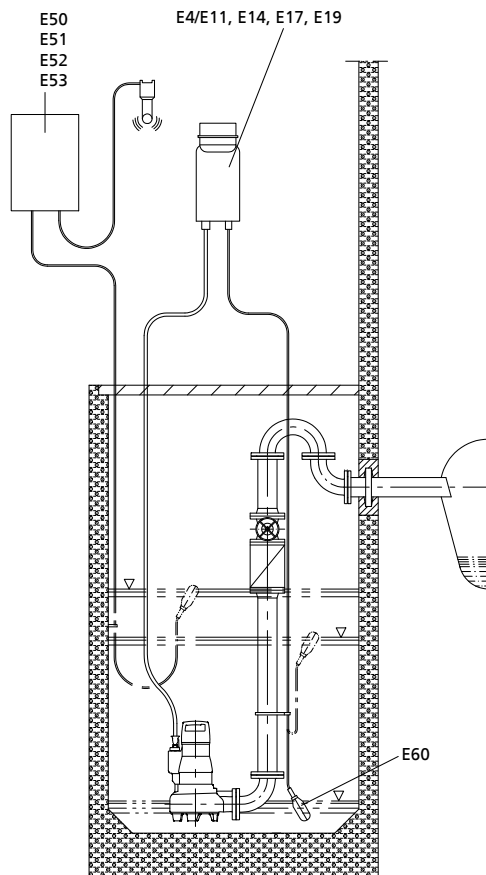

Suggested installation layout No. 1  
Non-explosionproof

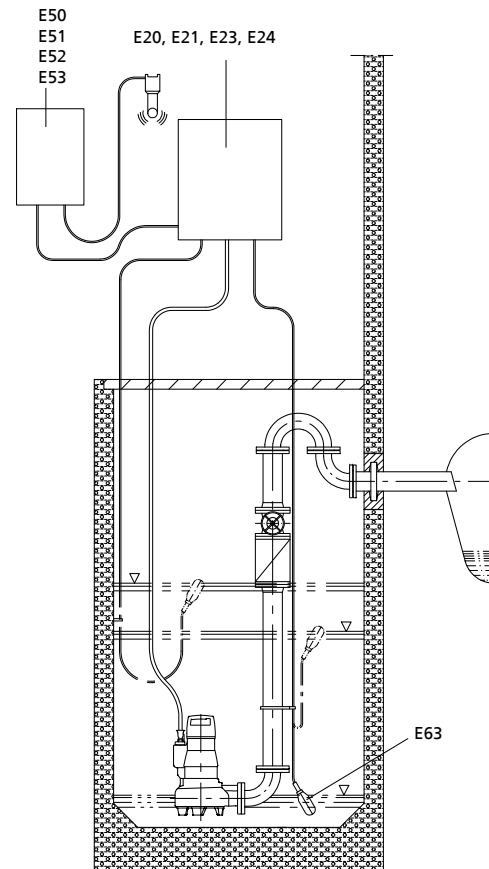

Suggested installation layout No. 2  
Explosion-proof

### Scope of supply

#### Stationary wet-installed model (installation type S)

- Pump set, complete with power cable
- Claw with sealing element (O-ring) and mounting elements
- Lifting rope/lifting chain<sup>20)</sup>
- Mounting bracket with mounting elements

- Duckfoot bend with mounting elements
- Guiding accessories  
(guide rails are not included in KSB's scope of supply)

#### Transportable wet-installed model (installation type P)

- Pump set, complete with power cable
- Feet (and foot plate, if applicable)
- Lifting rope/lifting chain<sup>21)</sup>

<sup>20)</sup> Optional

<sup>21)</sup> Optional



**Accessories**

**Installation parts for stationary pump sets**

Overview of installation parts for stationary installation

	Item	Description	Sizes	Connection/ installation depth	Mat. No.	[kg]	
<b>Guide hoop arrangement</b>							
	P2 + P5	Installation parts for stationary wet installation (guide hoop arrangement)  Consisting of: DN 50 flanged duckfoot bend, stainless steel anchor bolts, guide rail, claw with stainless steel screws/bolts	Amarex DN 50, DN 3: DIN ISO ASME straight claw	Inst. depth 1.5 m	39022210	9	
				Inst. depth 1.8 m	39022211	10	
				Inst. depth 2.1 m	39022212	11	
				Amarex N DN 50, DN 3: DIN ISO ASME inclined claw	Inst. depth 1.5 m	39022213	14
					Inst. depth 1.8 m	39022214	15
					Inst. depth 2.1 m	39022215	14
	P2 + P5	Installation parts for stationary wet installation (guide hoop arrangement)  Consisting of: DN 65 flanged duckfoot bend, stainless steel anchor bolts, guide hoop, claw with stainless steel screws/bolts	Amarex N DN 65, DN 3: DIN ISO ASME	Inst. depth 1.5 m	39020827	14.5	
				Inst. depth 1.8 m	39020828	15.5	
				Inst. depth 2.1 m	39020829	17	
	P2 + P5	Installation parts for stationary wet installation (guide hoop arrangement)  Consisting of: DN 65/80 flanged duckfoot bend, stainless steel anchor bolts, guide rail, claw with stainless steel screws/bolts	Amarex N DN 65/80, DN 3: DIN/ISO	Inst. depth 1.5 m	39020848	16	
				Inst. depth 1.8 m	39020849	17	
				Inst. depth 2.1 m	39020850	18.5	
				Amarex N DN 65/80, DN 3: ASME	Inst. depth 1.5 m	39022255	16
					Inst. depth 1.8 m	39022256	17
					Inst. depth 2.1 m	39022257	16
<b>Guide wire arrangement</b>							
	P4 + P5	Installation parts for stationary wet installation, installation depth 4.5 m (guide wire installation)  Consisting of: flanged duckfoot bend, stainless steel anchor bolts, suspension bracket, mounting bracket, 10 m guide wire, claw with stainless steel screws/bolts	Amarex N straight claw	DN 50, DN 3: DIN ISO ASME	39022196	13	
				Amarex N inclined claw	DN 50, DN 3: DIN ISO ASME	39022200	18
					DN 65, DN 3: DIN ISO ASME	39020820	13.8
				Amarex N DN 65/80, DN 3: DIN/ISO	DN 65/80, DN 3: DIN/ISO	39020834	19.1
					DN 65/80, DN 3: ASME	39020838	19.1
				Amarex N DN 80, DN 3: DIN/ISO	DN 80, DN 3: DIN/ISO	39020988	35
					DN 80, DN 3: ASME	39020992	41
				Amarex N DN 80/100, DIN ISO ASME	DN 80/100, DIN ISO ASME	39021002	31.5
					DN 100, DIN ISO ASME	39021009	41
<b>Single guide rail arrangement</b>							
	P4 + P5	Installation parts for wet-installed stationary pump sets (single guide rail arrangement) for installation depth = 4.5 m  Consisting of: flanged duckfoot bend, stainless steel anchor bolts, mounting bracket, claw with stainless steel screws/bolts (guide rail not included in KSB's scope of supply)	Amarex N straight claw	DN 50, DN 3: DIN ISO ASME	39022204	12.5	
				Amarex N inclined claw	DN 50, DN 3: DIN ISO ASME	39022207	18.5
					DN 65, DN 3: DIN ISO ASME	39021191	14.8
				Amarex N DN 65/80, DN 3: DIN/ISO	DN 65/80, DN 3: DIN/ISO	39021194	18.7
					DN 65/80, DN 3: ASME	39021197	19.2
				Amarex N DN 80, DN 3: DIN/ISO	DN 80, DN 3: DIN/ISO	39021200	26
					DN 80, DN 3: ASME	39021203	29.6
				Amarex N DN 80/DN 100, DN 3: DIN ISO ASME	DN 80/DN 100, DN 3: DIN ISO ASME	39021206	31
					DN 100, DN 3: DIN ISO ASME	39021209	26.8
				<b>Twin guide rail arrangement</b>			
	P4 + P5	Installation parts for stationary wet installation (twin guide rail arrangement)  Consisting of: flanged duckfoot bend, stainless steel anchor bolts, mounting bracket, adapter, claw with stainless steel screws/bolts (guide rails not included in KSB's scope of supply)	Amarex N inclined claw	DN 50, DN 3: DIN ISO ASME	39023002	14	
				Amarex N straight claw	DN 65, DN 3: DIN ISO ASME	39023006	19.5
					DN 65/80, DN 3: DIN/ISO	39023009	22.8
				Amarex N DN 65/80, DN 3: ASME	DN 65/80, DN 3: ASME	39023012	24.5
					DN 80, DN 3: DIN/ISO	39023018	32
				Amarex N DN 80/100, DN 3: DIN ISO ASME	DN 80, DN 3: ASME	39023021	32
					DN 80/100, DN 3: DIN ISO ASME	39023024	34
				Amarex N DN 100, DN 3: DIN ISO ASME	DN 100, DN 3: DIN ISO ASME	39023027	34
DN 100, DN 3: DIN ISO ASME							
<b>Claw</b>							

	Item	Description	Sizes	Connection/ installation depth	Mat. No.	[kg]			
	P5	Claw for Amarex N EN-GJL-250 with stainless steel screws/bolts  Guide hoop arrangement for DN 50 and DN 65; guide wire and single guide rail arrangement for all DN	Amarex N straight claw	DN 50	39022248	1.1			
			Amarex N inclined claw	DN 50	39022252	7			
			Amarex N	DN 65	39021018	1.9			
			Amarex N	DN 80/DN 100	39021020	3.1			
	P5	Claw for Amarex N EN-GJL-250 with stainless steel screws/bolts  Twin guide rail arrangement	Amarex N inclined claw	DN 50	39022990	6			
			Amarex N straight claw	DN 65	39022993	7.3			
				DN 80	39022996	9.7			
				DN 100	39022999	14.7			
				P5	Claw for Amarex EN-GJL-250 with stainless steel screws/bolts  Guide wire, single guide rail, guide hoop arrangement	Amarex straight claw	DN 50	39021016	1.1
						Amarex inclined claw	DN 50	19551046	5
Amarex	DN 65	39021018				1.9			
	DN 80/DN 100	39021020	3.1						
<b>Lifting bail</b>									
		Lifting bail made of stainless steel 1.4306 with A4-70 bolts, for lowering the pump set at an angle	Amarex N	DN 50	39022395	0.6			
				DN 65/DN 80/DN 100	39018004	1			
		Lifting bail made of stainless steel 1.4306 With A4-70 screws/bolts, for lowering the pump set in a vertical position	Amarex N	DN 32/50	39023593	0.85			
			Amarex N	DN 65/DN 80/DN 100	39023594	1.2			
<b>Conversion parts</b>									
		Parts for conversion to twin guide rail arrangement, consisting of: mounting bracket, stainless steel screws/bolts, adapter, anchor bolts  Note: required for conversion of guide hoop, guide wire or single guide rail arrangement to twin guide rail arrangement  Note: for twin guide rail arrangements a claw is mandatory.		DN 50/DN 65	39022984	1.4			
				DN 80/DN 100	39022987	2.5			

Off-standard designs on request.

### Installation parts for transportable pump sets

Overview of installation parts for transportable pump sets

	Item	Description	Sizes	Mat. No.	[kg]
	P6	3 feet Footplate incl. bolts  (only for uneven mounting surfaces and in combination with feet)	Amarex N DN 50, 65, 80, 100	39022260	0.4
			Amarex N DN 50, 65, 80, 100	39022262	0.9

**Chain for stationary and transportable pump sets**

Overview of chains for stationary and transportable pump sets









Item	Description	Sizes		Mat. No.	[kg]
P7	Chain (1.4404) short-linked, tested and duly labelled to Directive 2006/42/EC (Machinery Directive), hook (1.4301), shackle (1.4404) Maximum load: 160 kg	2 m	Amarex N DN 50, 65	39023811	1.2
		3 m	Amarex N DN 50, 65, 80, 100	39023812	1.6
		5 m	Amarex N DN 50, 65, 80, 100	39023813	2.4
		10 m	Amarex N DN 50, 65, 80, 100	39023814	4.4
	Polypropylene lifting rope with shackle 1.4401 and hook 1.4571 <sup>22)</sup>	5 m	Amarex N DN 50, 65, 80, 100	39021975	2.5

**Pump accessories**

Overview of accessories for stationary and transportable pump sets

	Item	Description	Connection	Amarex N				Mat. No.	[kg]	
				50	65	80	100			
	P8	Flange for pipe coupling PN 10, at the flanged elbow, mating dimensions to PN 16	DN 50/R2	X	-	-	-	19551111	1.2	
			DN 65/R2 1/2	-	X	-	-	39020184	1.2	
	P9	PVC adapter for hose connection, with 1 hose clip, plastic hose of inside diameter 63 item 19	R2	X	-	-	-	11191498	0.3	
	P13	Connection elbow with flange/hose connection made of EN-GJL-250, grey cast iron PN 16, DIN 2501, including joint ring and hose clip; for DN 100 also with fixing bolts To be used for flange connections item 25 / item 26 (not for DN 100).	DN 65/B 75	-	X	-	-	19135655	6	
			DN 80/B 75	-	-	X	-	19131746	6.6	
			DN 100/A 110	-	-	-	X	19139718	10	
	P14	Elbow with internal thread/external thread (to be used for flange connection item 27 and item 30), galvanised grey cast iron  Connection elbow with flanges PN 16, DIN 2501 (to be used for flange connections item 25 or item 26), grey cast iron	R2	X	-	-	-	00241966	0.3	
DN 65/65			-	X	-	-	00265480	11		
DN 65/80			-	X	-	-	25198402	8		
DN 80/80			-	-	X	-	11150856	10		
	P15	Storz rigid coupling with flange, to DIN 2501, drilled to PN 16 (to be used for flange connection item 25 or item 26), aluminium/steel	DN 65/B 75	-	X	-	-	18040148	3.5	
DN 80/B 75			-	-	X	-	18072642	3.5		
DN 100/A 110			-	-	-	X	18060162	5		
	P16	Storz hose coupling, aluminium alloy 2 hose clips, item 20, are required for hose mounting (for plastic hoses B 75 and A 110, item 19)	C 52 (DIN 14321)	X	-	-	-	00524551	0.3	
			B 75 (DIN 14322)	-	X	X	-	00520454	0.7	
			A 110 (DIN 14323)	-	-	-	X	00522313	1.5	
	P17	Storz rigid coupling with external thread to DIN ISO 228/1	C 52/G 2 A	X	-	-	-	00524370	0.2	
			B 75 - G 2 1/2	-	X	-	-	00524371	0.4	
	P18	Plastic hose DN 50, DIN 14811, with integrated C couplings	C 52	X	-	-	-	00522262	2.3	
			C 52	X	-	-	-	00522263	4.2	
			C 52	X	-	-	-	00522264	5.7	
	P19	Plastic hose without coupling, DIN 14 811	63	5	X	-	-	-	39018688	1.7
				10	X	-	-	-	39018689	3.4
				20	X	-	-	-	39018690	6.8
			B 75	5	-	X	X	-	39019064	2
				20	-	X	X	-	39019066	8
				30	-	X	X	-	39019071	12
			80	5	-	-	X	-	39018691	2.2

<sup>22)</sup> Increase quantity for larger installation depths.

	Item	Description	Connection	Amarex N				Mat. No.	[kg]
				50	65	80	100		
			10	-	-	X	-	39019062	4.3
		A 110	5	-	-	-	X	39019067	4.7
			10	-	-	-	X	39019068	9.3
			30	-	-	-	X	39019070	27.9
	P20	Hose clip DIN 3017, chrome steel	B 50 <sup>23)</sup>	X	-	-	-	39000515	0.025
			B 75	-	X	X	-	00109515	0.04
			AL 110 - 120 B <sup>24)</sup>	-	-	-	X	00520853	0.1
	P21	RK swing check valve Plastic, EN 12 050-4, with internal thread ISO 7/1, full port and drain plug; cannot be used for pumped drainage	Rp 2	X	-	-	-	01009773	0.5
	P22	Socket gate valve CuZn PN 10-12 DIN 3352	Rp 2	X	-	-	-	00411503	1.287
			Rp 2 1/2	-	X	-	-	39000507	1.7
	P23	KSB swing check valve, grey cast iron With full port, lifting device, flanges drilled to DIN 2501, PN 16 (not for lifting units)	DN 65	-	X	-	-	48829253	16.2
			DN 80	-	-	X	-	48829254	21.5
			DN 100	-	-	-	X	48829255	29
	P24	ECOLINE GTR-16P gate valve, grey cast iron, PN 16, flanges drilled to ISO 7005/DIN 2501	DN 65	-	X	-	-	49709579	15
			DN 80	-	-	X	-	49709580	22
			DN 100	-	-	-	X	49709581	26.5
	P25	Set of installation accessories for a flange connection, discharge nozzle; item 13, 14 or 15 Consisting of: 4 hexagon head bolts with nuts and 1 sealing element		X	-	-	-	39021944	0.8
				-	X	-	-	19551115	0.8
				-	-	X	-	19551100	0.8
				-	-	-	X	19551113	0.8
	P26	Set of installation accessories for a flange connection, Consisting of: 8 hexagon head bolts with nuts and 1 sealing element		-	-	X	-	19551114	0.8
				-	-	-	X	19551116	0.8
	P27	Threaded flange for guide hoop arrangement (P2) and guide wire arrangement (P4) Consisting of: flange, 4 hexagon head bolts with nuts and washers and 1 sealing element	DN 50/Rp 2	X	-	-	-	19551353	2
			DN 65/Rp 2 1/2	-	X	-	-	39021943	2.9
	P28	Hand pump, wall mounting, grey cast iron, suction-side connection Rp 1 1/2		X	X	X	X	00520485	12
	P30	Adapter with reduced external thread M4 EN 1042K	2 x 1 1/4	-	-	-	-	01135663	0.4

23) For plastic hose Ø 63 item 19

24) 2 units required

**Electrical accessories**

**Control units, non-ATEX compliant**

**i** Valid for all countries except France.  
Control units for Amarex N without ATEX

Item	Description	Power min [A]	Power max [A]	Type	Mat. No.	[kg]
E4	Multi-functional plug, type Hyper, with motor protection relay CEE plug	2,6	3,7	Hyper 37.1	19071492	1
		3,7	5,5	Hyper 55.1	19071493	1
		5,5	8,0	Hyper 80.1	19071494	1
		8,0	11,5	Hyper 115.1	19071495	1
<b>LevelControl Basic 2 control unit for single-pump station, IP 54</b>						
E11	For float switch or 4...20 mA sensor, optional master switch, 400 x 281 x 135 mm	2,5	4,0	BC1 400 <sup>DFNO</sup> 040	19073763	4.5
		4,0	6,3	BC1 400 <sup>DFNO</sup> 063	19073764	4.5
		6,3	10,0	BC1 400 <sup>DFNO</sup> 100	19073765	4.5
E14	Pneumatic, optional master switch, 400 x 281 x 135 mm	2,5	4,0	BC1 400 <sup>DPNO</sup> 040	19073768	4.5
		4,0	6,3	BC1 400 <sup>DPNO</sup> 063	19073769	4.5
		6,3	10,0	BC1 400 <sup>DPNO</sup> 100	19073770	4.5
E17	Bubbler control, with master switch, 400 x 300 x 155 mm	2,5	4,0	BS1 400 <sup>DLNO</sup> 040	19073818	12
		4,0	6,3	BS1 400 <sup>DLNO</sup> 063	19073819	12
		6,3	10,0	BS1 400 <sup>DLNO</sup> 100	19073820	12
E19	Bubbler control for BC version Only to be used for connections with neutral conductors! Optional component O1 (master switch) not possible! 400 x 281 x 135 mm	2,5	4,0	BC1 400 <sup>DLNO</sup> 040	19075148	4.5
		4,0	6,3	BC1 400 <sup>DLNO</sup> 063	19075149	4.5
		6,3	10,0	BC1 400 <sup>DLNO</sup> 100	19075150	4.5
<b>LevelControl Basic 2 control unit for dual-pump station, IP 54</b>						
E 31	For float switch or 4...20 mA sensor, optionally with master switch, 400 x 281 x 135 mm	2,5	4,0	BC2 400 <sup>DFNO</sup> 040	19073777	4.7
		4,0	6,3	BC2 400 <sup>DFNO</sup> 063	19073778	4.7
		6,3	10,0	BC2 400 <sup>DFNO</sup> 100	19073779	4.7
E34	Pneumatic, optional master switch, 400 x 281 x 135 mm	2,5	4,0	BC2 400 <sup>DPNO</sup> 040	19073782	4.7
		4,0	6,3	BC2 400 <sup>DPNO</sup> 063	19073783	4.7
		6,3	10,0	BC2 400 <sup>DPNO</sup> 100	19073784	4.7
E37	Bubbler control, with master switch, 400 x 300 x 155 mm	2,5	4,0	BS2 400 <sup>DLNO</sup> 040	19073860	13
		4,0	6,3	BS2 400 <sup>DLNO</sup> 063	19073861	13
		6,3	10,0	BS2 400 <sup>DLNO</sup> 100	19073862	13
E39	Bubbler control for BC version Only to be used for connections with neutral conductors! Optional component O1 (master switch) not possible! 400 x 281 x 135 mm	2,5	4,0	BC2 400 <sup>DLNO</sup> 040	19075151	4.7
		4,0	6,3	BC2 400 <sup>DLNO</sup> 063	19075152	4.7
		6,3	10,0	BC2 400 <sup>DLNO</sup> 100	19075153	4.7

**i** Only valid for France!  
Control units for Amarex N without ATEX





Item	Description	Power min [A]	Power max [A]	Type	Mat. No.	[kg]
E4	Multi-functional plug, type Hyper, with motor protection relay CEE plug	2,6	3,7	Hyper 37.1	19071492	1
		3,7	5,5	Hyper 55.1	19071493	1
		5,5	8,0	Hyper 80.1	19071494	1
		8,0	11,5	Hyper 115.1	19071495	1
<b>LevelControl Basic 2 control unit for single-pump stations</b>						
E11	For float switch or 4...20 mA sensor, with master switch, 400 x 278 x 120 mm	2,5	4,0	BC1 400 <sup>DFNO</sup> 040 02	19073878	4.5
		4,0	6,0	BC1 400 <sup>DFNO</sup> 063 02	19073879	4.5
		6,0	10,0	BC1 400 <sup>DFNO</sup> 100 02	19073880	4.5
E14	Pneumatic, with master switch, 400 x 278 x 120 mm	2,5	4,0	BC1 400 <sup>DPNO</sup> 040 02	25)	25)
		4,0	6,3	BC1 400 <sup>DPNO</sup> 063 02	25)	25)
		6,3	10,0	BC1 400 <sup>DPNO</sup> 100 02	25)	25)
E17	Bubbler control, with master switch, 400 x 300 x 155 mm	2,5	4,0	BS1 400 <sup>DLNO</sup> 040 02	25)	25)
		4,0	6,3	BS1 400 <sup>DLNO</sup> 063 02	25)	25)
		6,3	10,0	BS1 400 <sup>DLNO</sup> 100 02	25)	25)

25) See KSB Easy Select

Item	Description	Power min [A]	Power max [A]	Type	Mat. No.	[kg]
<b>LevelControl Basic 2 control unit for dual-pump stations</b>						
E11	For float switch or 4...20 mA sensor, optional master switch, 400 x 278 x 120 mm	2,5	4,0	BC2 400 <sup>DFNO</sup> 040 02	19073888	4.7
		4,0	6,3	BC2 400 <sup>DFNO</sup> 063 02	19073889	4.7
		6,0	10,0	BC2 400 <sup>DFNO</sup> 100 02	19073890	4.7
E14	Pneumatic, with master switch, 400 x 278 x 120 mm	2,5	4,0	BC2 400 <sup>DPNO</sup> 040 02	25)	25)
		4,0	6,3	BC2 400 <sup>DPNO</sup> 063 02	25)	25)
		6,3	10,0	BC2 400 <sup>DPNO</sup> 100 02	25)	25)
E17	Bubbler control, with master switch, 400 x 300 x 155 mm	2,5	4,0	BS2 400 <sup>DLNO</sup> 040 02	25)	25)
		4,0	6,3	BS2 400 <sup>DLNO</sup> 063 02	25)	25)
		6,3	10,0	BS2 400 <sup>DLNO</sup> 100 02	25)	25)





### Alarm switchgears for pumps without ATEX

AS 0/AS 1/AS 2/AS 4/AS 5

	Item	Description	Mat. No.	[kg]
	E50	Alarm switchgear AS 0 With circuit breaker, acoustic signal transmitter with 85 dB(A), green equipment-on lamp Plastic housing IP20, 140 x 80 x 57 mm. Use float switch, F1 moisture sensor (item E64), M1 alarm contactor or signal relay of control unit as contactor.	29128401	0.5
	E51	Alarm switchgear AS 2 With circuit breaker, acoustic signal with 85 dB(A), green equipment-on lamp, volt-free contact for hook-up to a control station Plastic housing IP 20, 140 x 80 x 57 mm. Use float switch, F1 moisture sensor (item E 64) or signal relay of control unit as contactor.	29128422	0.5
	E52	Alarm switchgear AS 4 With circuit breaker, acoustic signal transmitter with 85 dB(A), green equipment-on lamp, volt-free contact for hook-up to a control station, self-charging power supply unit for 5 hours of operation in the event of a power failure Plastic housing IP20, 140 x 80 x 57 mm. Use float switch (E60), F1 moisture sensor (item E64) or signal relay of control unit as contactor.	29128442	0.5
	E53	Alarm switchgear AS 5 Mains-independent, with self-charging power supply unit for 10 hours of operation in the event of a power failure, mains pilot LED, fault indicator light, horn-off push button, volt-free contact for hook-up to a control station, ready for connection with 1.8 m connection cable and plug. ISO housing IP41, 190 x 165 x 75 mm. Use float switch (E60) or signal relay of control unit as contactor.	00530561	1.7
	E55	Alarm switchgear AS 1 In IP30 ISO plug housing, mains-independent, with self-charging power supply unit for 5 hours of operation in the event of a power failure, acoustic signal transmitter 70 dB(A) with circuit breaker and integrated signal transmitter with 3-metre connection cable, max. 60 °C, not suitable for steam and condensate.  1. High water alert by suspending the moisture sensor in a (pump) sump above the pump start-up point.  2. Water alarm signal at a water level of only 1 mm (!), by placing the contactor on the floor of rooms at risk of flooding, e.g. the cellar or next to the washing machine in the kitchen or bathroom.	00533740	0.9









**Alarm switchgears for pumps without ATEX**

AS 0/AS 1/AS 2/AS 4/AS 5

	Item	Description	Mat. No.	[kg]
	E50	Alarm switchgear AS 0 With circuit breaker, acoustic signal transmitter with 85 dB(A), green equipment-on lamp Plastic housing IP20, 140 x 80 x 57 mm. Use float switch, F1 moisture sensor (item E64), M1 alarm contactor or signal relay of control unit as contactor.	29128401	0.5
	E51	Alarm switchgear AS 2 With circuit breaker, acoustic signal with 85 dB(A), green equipment-on lamp, volt-free contact for hook-up to a control station Plastic housing IP 20, 140 x 80 x 57 mm. Use float switch, F1 moisture sensor (item E 64) or signal relay of control unit as contactor.	29128422	0.5
	E52	Alarm switchgear AS 4 With circuit breaker, acoustic signal transmitter with 85 dB(A), green equipment-on lamp, volt-free contact for hook-up to a control station, self-charging power supply unit for 5 hours of operation in the event of a power failure Plastic housing IP20, 140 x 80 x 57 mm. Use float switch (E60), F1 moisture sensor (item E64) or signal relay of control unit as contactor.	29128442	0.5
	E53	Alarm switchgear AS 5 Mains-independent, with self-charging power supply unit for 10 hours of operation in the event of a power failure, mains pilot LED, fault indicator light, horn-off push button, volt-free contact for hook-up to a control station, ready for connection with 1.8 m connection cable and plug. ISO housing IP41, 190 x 165 x 75 mm. Use float switch (E60) or signal relay of control unit as contactor.	00530561	1.7
	E55	Alarm switchgear AS 1 In IP30 ISO plug housing, mains-independent, with self-charging power supply unit for 5 hours of operation in the event of a power failure, acoustic signal transmitter 70 dB(A) with circuit breaker and integrated signal transmitter with 3-metre connection cable, max. 60 °C, not suitable for steam and condensate. 1. High water alert by suspending the moisture sensor in a (pump) sump above the pump start-up point. 2. Water alarm signal at a water level of only 1 mm (!), by placing the contactor on the floor of rooms at risk of flooding, e.g. the cellar or next to the washing machine in the kitchen or bathroom.	00533740	0.9

### Accessories for non-ATEX control units

Overview of control unit accessories for Amarex N, non-ATEX compliant

	Item	Description		Mat. No.	[kg]
	E60	Float switch with free cable end (NO contact) Switch housing made of polypropylene (max. fluid temperature 70 °C), circuit closed in upper float position, connection cable (H07RN-F3G1)	3 m	11037742	0.5
			5 m	11037743	0.8
			10 m	11037744	1.3
			15 m	11037745	1.8
			20 m	11037746	2.4
			25 m	11037747	2.9
			30 m	11037748	3.4
	E62	Float switch with free cable end (NC contact), Circuit open in upper float position, power cable (H07RN-F 3G1)	5 m	11037756	0.8
			10 m	11037757	1.4
			20 m	11037758	2.6
	E64	Leakage sensor F 1	3 m	19072366	0.2
	E65	Open pressure bell set - pneumatic and bubbler control with polyamide tube 8 x 1 mm	Tube length 10 m	19071721	1.2
			Tube length 20 m	19071837	2
			Tube length 50 m	19074200	2.5
	E66	Closed pressure bell set - pneumatic with polyamide tube 8 x 3 mm	Tube length 10 m	19071722	3.5
			Tube length > 10 m		
	E70	Horn, 12 V DC, 105 dB, 150 mA, IP54, with 0.45 m connection cable		01086547	0.1
	E71	Alarm combination, 12 V DC		01139930	0.1
	E72	Yellow alarm strobe light, 12 V DC, 195 mA, IP65		01056355	0.3
	E73	PC service tool		47121210	0.2
	E90	Rechargeable battery retrofit kit for LevelControl Basic 2. Powers the electronics, float switches, level sensor(s) or the internal pressure sensor and the alarm equipment (buzzer, horn, alarm combination), for single-pump and dual-pump stations.	For type BC, includes 2 rechargeable batteries 6 V, 1.3 Ah and charging unit	19074194	0.8
	E91		For type BS, consisting of 1 rechargeable battery 12 V, 1.2 Ah and charging unit	19074199	1



**ATEX-compliant control units**

**i** The control units are not explosion-proof, which means that they must not be operated in potentially explosive atmospheres.

**i** For ATEX-compliant variants, intrinsic safety barriers and an ATEX level switch (float switch) must be fitted. Selection via KSB EasySelect.

**i** **Valid for all countries except France.**

Control unit accessories for Amarex N with ATEX

Item	Description	Power min [A]	Power max [A]	Type	Mat. No.	[kg]
<b>LevelControl Basic 2 control unit for single-pump station</b>						
E20	Float switch, with master switch, 600 x 400 x 200 mm	2,5	4,0	BS1 400 <sup>DPEO</sup> 040	19073800	12
		4,0	6,3	BS1 400 <sup>DPEO</sup> 063	19073801	12
		6,3	10,0	BS1 400 <sup>DPEO</sup> 100	19073802	12
E21	Pneumatic, optional master switch, 400 x 281 x 135 mm	2,5	4,0	BC1 400 <sup>DPEO</sup> 040	19073771	4.5
		4,0	6,3	BC1 400 <sup>DPEO</sup> 063	19073772	4.5
		6,3	10,0	BC1 400 <sup>DPEO</sup> 100	19073773	4.5
E23	Bubbler control, with master switch, 400 x 300 x 155 mm	2,5	4,0	BS1 400 <sup>DLEO</sup> 040	19073821	12
		4,0	6,3	BS1 400 <sup>DLEO</sup> 063	19073822	12
		6,3	10,0	BS1 400 <sup>DLEO</sup> 100	19073823	12
E24	Bubbler control for BC version Only to be used for connections with neutral conductors! Optional component O1 (master switch) not possible! 400 x 281 x 135 mm	2,5	4,0	BC1 400 <sup>DLEO</sup> 040	19075154	4.5
		4,0	6,3	BC1 400 <sup>DLEO</sup> 063	19075155	4.5
		6,3	10,0	BC1 400 <sup>DLEO</sup> 100	19075156	4.5
<b>LevelControl Basic 2 control unit for dual-pump station</b>						
E40	Float switch, with master switch, 600 x 400 x 200 mm	2,5	4,0	BS2 400 <sup>DPEO</sup> 040	19073842	13
		4,0	6,3	BS2 400 <sup>DPEO</sup> 063	19073843	13
		6,3	10,0	BS2 400 <sup>DPEO</sup> 100	19073844	13
E41	Pneumatic, optional master switch, 400 x 281 x 135 mm	2,5	4,0	BC2 400 <sup>DPEO</sup> 040	19073785	4.7
		4,0	6,3	BC2 400 <sup>DPEO</sup> 063	19073786	4.7
		6,3	10,0	BC2 400 <sup>DPEO</sup> 100	19073787	4.7
E43	Bubbler control, with master switch, 400 x 300 x 155 mm	2,5	4,0	BS2 400 <sup>DLEO</sup> 040	19073863	13
		4,0	6,3	BS2 400 <sup>DLEO</sup> 063	19073864	13
		6,3	10,0	BS2 400 <sup>DLEO</sup> 100	19073865	13
E44	Bubbler control for BC version Only to be used for connections with neutral conductors! Optional component O1 (master switch) not possible! 400 x 281 x 135 mm	2,5	4,0	BC2 400 <sup>DLEO</sup> 040	19075157	4.7
		4,0	6,3	BC2 400 <sup>DLEO</sup> 063	19075158	4.7
		6,3	10,0	BC2 400 <sup>DLEO</sup> 100	19075159	4.7

**i** **Only valid for France!**

Control unit accessories for Amarex N with ATEX





Item	Description	Power min [A]	Power max [A]	Type	Mat. No.	[kg]
<b>LevelControl Basic 2 control unit for single-pump stations</b>						
E20	Float switch, with master switch, 600 x 400 x 200 mm	2,5	4,0	BS1 400 <sup>DPEO</sup> 040 02	26)	26)
		4,0	6,3	BS1 400 <sup>DPEO</sup> 063 02	26)	26)
		6,3	10,0	BS1 400 <sup>DPEO</sup> 100 02	26)	26)
E21	Pneumatic, with master switch, 400 x 278 x 120 mm	2,5	4,0	BC1 400 <sup>DPEO</sup> 040 02	26)	26)
		4,0	6,3	BC1 400 <sup>DPEO</sup> 063 02	26)	26)
		6,3	10,0	BC1 400 <sup>DPEO</sup> 100 02	26)	26)
E23	Bubbler control, with master switch, 400 x 300 x 155 mm	2,5	4,0	BS1 400 <sup>DLEO</sup> 040 02	26)	26)
		4,0	6,3	BS1 400 <sup>DLEO</sup> 063 02	26)	26)
		6,3	10,0	BS1 400 <sup>DLEO</sup> 100 02	26)	26)
<b>LevelControl Basic 2 control unit for dual-pump stations</b>						
E40	Float switch, with master switch, 600 x 400 x 200 mm	2,5	4,0	BS2 400 <sup>DPEO</sup> 040 02	26)	26)
		4,0	6,3	BS2 400 <sup>DPEO</sup> 063 02	26)	26)
		6,3	10,0	BS2 400 <sup>DPEO</sup> 100 02	26)	26)
41	Pneumatic, with master switch, 400 x 278 x 120 mm	2,5	4,0	BC2 400 <sup>DPEO</sup> 040 02	26)	26)

26) See KSB Easy Select

Item	Description	Power min [A]	Power max [A]	Type	Mat. No.	[kg]
		4,0	6,3	BC2 400 DPEO 063 02	26)	26)
		6,3	10,0	BC2 400 DPEO 100 02	26)	26)
E43	Bubbler control, with master switch, 400 x 300 x 155 mm	2,5	4,0	BS2 400 DLEO 040 02	26)	26)
		4,0	6,3	BS2 400 DLEO 063 02	26)	26)
		6,3	10,0	BS2 400 DLEO 100 02	26)	26)

### Accessories for ATEX-compliant control units

Overview of accessories for Amarex N with ATEX

	Item	Description		Mat. No.	[kg]
	E63	Float switch with free cable end (NO contact) With declaration of compliance with explosion protection standards Power cable (H 07 RN-F3G1)	5 m	01148226	0.7
			10 m	01148247	1
			20 m	01148248	2
	E65	Open pressure bell set - pneumatic and bubbler control with polyamide tube 8 x 1 mm	Tube length 10 m	19071721	1.2
			Tube length 20 m	19071837	2
			Tube length 50 m	19074200	2.5
	E66	Closed pressure bell set - pneumatic with polyamide tube 8 x 3 mm	Tube length 10 m	19071722	3.5
			Tube length > 10 m		
	E70	Horn, 12 V DC, 105 dB, 150 mA, IP54, with 0.45 m connection cable, not explosion-proof		01086547	0.1
	E71	Alarm combination, 12 V DC not explosion-proof		01139930	0.1
	E72	Yellow alarm strobe light, 12 V DC, 195 mA, IP65, not explosion-proof		01056355	0.3
	O45	Plastic housing, (W) 82 x (H) 55 x (D) 106.5 [mm], IP65, for easier installation of alarm strobe light, for wall mounting		01061067	0.2
	E73	PC service tool		47121210	0.2
	E90	Rechargeable battery retrofit kit for LevelControl Basic 2. Powers the electronics, float switches, level sensor(s) or the internal pressure sensor and the alarm equipment (buzzer, horn, alarm combination), for single-pump and dual-pump stations.	For type BC, includes 2 rechargeable batteries 6 V, 1.3 Ah and charging unit	19074194	0.8
	E91		For type BS, consisting of 1 rechargeable battery 12 V, 1.2 Ah and charging unit	19074199	1



**KSB Aktiengesellschaft**

P.O. Box 200743 • 06008 Halle (Saale) • Turmstraße 92 • 06110 Halle (Germany)

Tel. +49 345 4826-0 • Fax +49 345 4826-4699

[www.ksb.com](http://www.ksb.com)

16.03.2016

2563.5/15-EN