

Submersible Grinder Pump Type ABS Piranha S10 - PE125

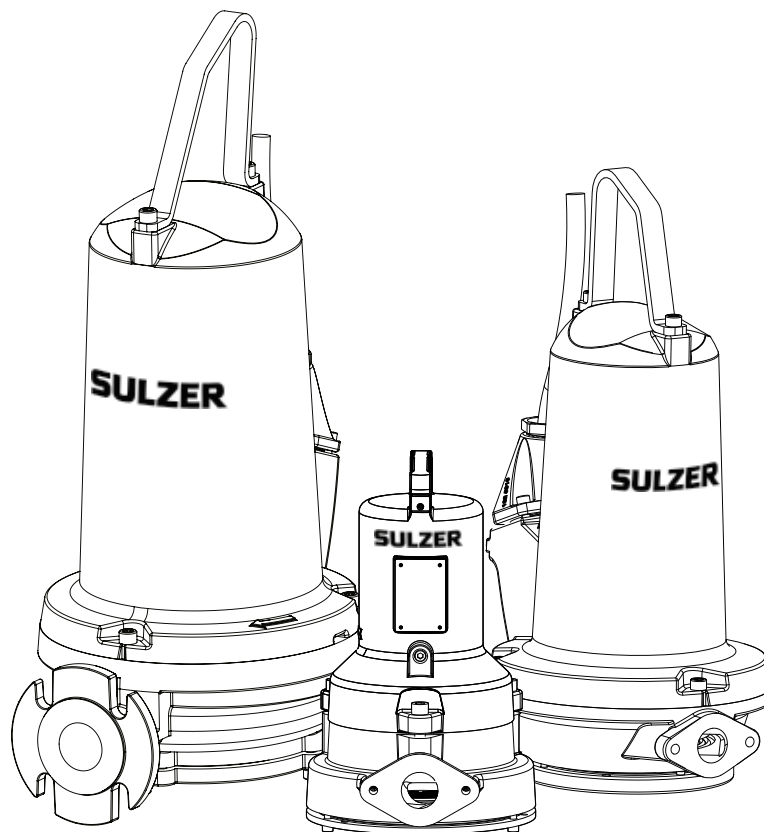

Submersible Grinder Pump Type ABS Piranha**50 Hz:**

Ex⁽¹⁾ & Non-Ex	Ex⁽¹⁾
S10/4W-50	PE30/2C-50
S12/2-50	PE 55/2E-50
S12/2W-50	PE70/2E-50
S13/4-50	PE90/2E-50
S17/2-50	PE110/2E-50
S17/2W-50	
S21/2-50	
S26/2-50	

60 Hz:

Ex⁽²⁾ & Non-Ex⁽³⁾	Ex⁽²⁾ & Non-Ex⁽³⁾	Ex⁽²⁾ & Non-Ex⁽³⁾
S10/4-60	PE25/2W-C-60	PE80/2-E-60
S10/4W-60	PE28/2-C-60	PE100/2-E-60
S20/2-60	PE35/2-C-60	PE110/2-E-60
S20/2W-60	PE35/2W-C-60	PE125/2-E-60
S26/2W-60	PE45/2-C-60	
S30/2-60	PE45/2W-C-60	

Approvals:⁽¹⁾ ATEX. ⁽²⁾ FM. ⁽³⁾ CSA.**Contents**

1	Application areas	3
1.1	Explosion-proof approval	3
2	Safety	3
2.1	Use of explosion-proof pumps in explosive zones	3
2.2	Special conditions for safe use of S-type, explosion-proof motors.	3
3	Technical data	4
3.1	Nameplate	4
4	General design features	6
4.1	Design features Piranha-S	6
4.2	Design features Piranha-PE	7
5	Types of operation and frequency of starting	8
6	Weights	8
6.1	Piranha-PE	8
6.2	Chain (DIN 763)	8
7	Transport and storage	9
7.1	Transport	9
7.2	Storage	9
7.2.1	Moisture protection of motor connection cable	9
8	Mounting and installation	10
8.1	Installation example in concrete sump	10
8.2	Venting of the volute	10
8.3	Discharge line	11
9	Electrical connection	11
9.1	Temperature monitoring	11
9.2	Seal monitoring	11
9.3	Wiring diagrams	12
9.4	Checking direction of rotation	13
9.5	Changing direction of rotation	13
10	Commissioning	13
11	Maintenance and service	14
11.1	General maintenance hints	14
11.2	Shredding system	14
11.3	Oil filling and changing	14
11.4	Oil-fill quantities	15
11.5	Bearings and mechanical seals	15
11.6	Maintenance of lifting stations in accordance with EN 12056.	15
11.7	Cleaning	15
12	Troubleshooting guide	16

Symbols and notices used in this booklet:



Presence of dangerous voltage.



Non-compliance may result in personal injury.



Danger of an explosion occurring.

ATTENTION! Non-observance may result in damage to the unit or negatively affect its performance.

NOTE: Important information for particular attention.

1 Application areas

Piranha submersible grinder pumps have been designed for the pumping of sewage containing faecal matter from buildings and sites where the location is below the sewer level.

In addition Piranha pumps are ideal for effective and economical pressurised dewatering using pipes of small cross-sectional area, in private, municipal, and industrial applications.

The regulations of DIN EN 12056-4 as well as other local codes should be observed.

ATTENTION *The maximum allowable temperature of the medium pumped is 40 °C.*

1.1 Explosion-proof approval

Explosion-proof motors of the Piranha series have certification in accordance with Factory Mutual (FM) Class 1 Div. 1 Groups C and D (60 Hz, US), and ATEX 2014/34/EU [II 2G Ex db IIB T4 Gb] (50 Hz).

2 Safety

The general and specific health and safety requirements are described in detail in the “**Safety Instructions for Sulzer Products Type ABS**” booklet. If anything is not clear or you have any questions as to safety make certain to contact the manufacturer Sulzer.

This unit can be used by children aged 8 years and above, and persons with reduced physical, sensory, or mental capabilities, or lack of experience and knowledge, when they have been given supervision or instruction concerning the safe use of the device and understand the hazards involved. Children must not play with the appliance. Cleaning and user maintenance should not be performed by children without supervision.

2.1 Use of explosion-proof pumps in explosive zones.

1. Explosion-proof submersible pumps may only be operated with the thermal sensing system connected.
2. Float switches and seal monitoring (DI) must be connected via an intrinsically safe electrical circuit, Protection Type EX (i), in accordance with IEC 60079-11.
3. Dismantling and repair of submersible explosion-proof motors may only be carried out by approved personnel in specially approved work shops.

2.2 Special conditions for safe use of S-type, explosion-proof motors.

1. The integral supply cable shall be suitably protected from mechanical damage and terminated within an appropriate termination facility.
2. Pump motors rated for use with 50/60 Hz sinusoidal supplies shall have the thermal protection devices connected in such a way that the machine is isolated from the supply in the event of the stator reaching 130 °C.
3. Pump motors rated for use with variable frequency or non-sinusoidal supplies shall have the thermal protection devices connected in such a way that the machine is isolated from the supply in the event of the stator reaching 100 °C for T4 classified machines, or 160 °C for T3C classified machines.
4. These motor units are not intended for user service or repair, any operation that may affect the explosion protection characteristics should be referred to the manufacturer. Repairs on flameproof joints may only be performed in accordance with the manufacturer’s design specifications.

3 Technical data

Detailed technical information is available in the technical data sheet Submersible Grinder Pump Type ABS Piranha which can be downloaded from www.sulzer.com > Products > Pumps > Submersible Pumps.

Maximum noise level ≤ 70 dB. This may be exceeded in certain circumstances.

3.1 Nameplate

We recommend that you record the data from the nameplate on the pump in the corresponding form below, and maintain it as a source of reference for the ordering of spare parts, repeat orders and general queries.

Always state the pump type, item no. and serial no. in all communications.

ATEX- and FM-rated Piranha pumps are approved for use in hazardous locations. If an Ex-rated pump is serviced or repaired in a workshop that is not Ex-approved then it must no longer be used in hazardous locations. In that case the Ex nameplate must be removed and replaced by the standard nameplate, or where instead a standard and a secondary Ex nameplate is fitted to the pump the secondary nameplate must be removed.

Standard nameplate

SULZER xx/xxxx IP 68

Typ
Nr _____ Sn _____

U _N	I _N	Ph	Hz
P1:	Cos φ	n	
P2:	Insul. Cl.F		
Q _{max}	H _{max}		
DN	H _{min}	Ø Imp	

Sulzer Pump Solutions Ireland Ltd.
Wexford, Ireland.
Made in Ireland www.sulzer.com

1003-03

Piranha-S

SULZER xx/xxxx IP 68

Typ
Nr _____ Sn _____

U _N	I _N	Ph	Hz
P1:	Cos φ	n	
P2:	Weight		
Q _{max}	H _{max}		
DN	H _{min}	Ø Imp	

Sulzer Pump Solutions Ireland Ltd.
Wexford, Ireland.
Made in Ireland www.sulzer.com

1231-00

Piranha-PE

ATEX nameplate

SULZER 1180 xx/xxxx IP 68
Baseefa 03ATEX07.X II 2G Ex db IIB T4 Gb

Typ
Nr _____ Sn _____ Insul.Cl.H

U _N	I _N	Cos φ	Ph	Hz
P1:	P2:	n		
Q _{max}	H _{max}			
DN	H _{min}	Ø Imp		

Connection information for the temperature controller is in the installation instructions. Do not open while energized.

Anschlussinweise für die Temperaturwächter in der Montage- u. Betriebsanleitung beachten. Nicht unter Spannung öffnen.

Sulzer Pump Solutions Ireland Ltd.
Wexford, Ireland.
Made in Ireland www.sulzer.com

1001-04

Piranha-S

1180

II 2G Ex db IIB T4 Gb PTB 10 ATEX 1062 X

Do not open while energized
Nicht unter Spannung öffnen

4224
5026

1232-02

Piranha-PE

Legend

Typ	Pump type	
Nr	Item number	
Sn	Serial number	
xx/xxxx	Production date (week/year)	
U _N	Rated voltage	V
I _N	Rated current	A
Ph	Number of phases	
Hz	Frequency	Hz
Insul. Cl.	Insulation class	

P1	Rated input power	kW
P2	Rated output power	kW
n	Speed	r/min
Cos φ	Power factor	pf
Q _{max}	Maximum flow	m ³ /h
H _{max}	Maximum head	m
Ø Imp.	Impeller diameter	mm
DN	Discharge diameter	mm

FM nameplate

SULZER			IP 68
APPROVED		Explosion Proof CL.1 DIV.1 GR.C+D	
SUBMERSIBLE WASTEWATER PUMP MOTOR		000000	XX/XXXX
Model:	#####	Sn	
Volts:	P2:	F.L. Amps	
Hz	Ph	RPM:	Insul.Cl.F
AMB. TEMP.40 °C		OPER. TEMP. T3C	
Pump:		Imp. Dia:	
Flow Max:		Hmax	
DO NOT REMOVE COVER WHILE CIRCUIT IS ALIVE			
Sulzer Pump Solutions Ireland Ltd.			
Wexford, Ireland.			
Made in Ireland	www.sulzer.com		

Piranha-S and Piranha-PE

CSA nameplate

SULZER			IP 68
		LR51412	000000
SUBMERSIBLE WASTEWATER PUMP MOTOR		000000	XX/XXXX
Model:		Sn	
Nr.		Sn	
Volts:		F.L. Amps:	
Hz	Phase	RPM:	P2:
Max. Amb. Temp.40 °C		Insul.Cl.F	
Imp. Dia:		NEMA Code: A	
Flow Max:		Hmax	
Use with approved motor control that matches motor input full load amps.			
Utiliser un démarreur approuvé convenant au courant à pleine charge du moteur.			
Sulzer Pump Solutions Ireland Ltd.			
Wexford, Ireland.			
Made in Ireland	www.sulzer.com		

Piranha-S and Piranha-PE

Legend

Model	Pump type/ Item number
Sn	Serial number
Volts	Rated voltage
P2	Rated output power
F.L.Amps	Full load amps
Hz	Frequency
Ph	Three/single phase

RPM	Speed
Imp. dia	Impeller diameter
Max. ▽	Max submersible depth
Insul. Cl.	Insulation class
NEMA Code	
Flow Max.	Maximum flow
Hmax	Maximum head

4 General design features

Submersible grinder pump fitted with a shredding system hydraulic.

The shredding system is located before the impeller and consists of a shredding rotor in combination with a stationary cutting ring fixed to a spiral bottom plate.

4.1 Design features Piranha-S

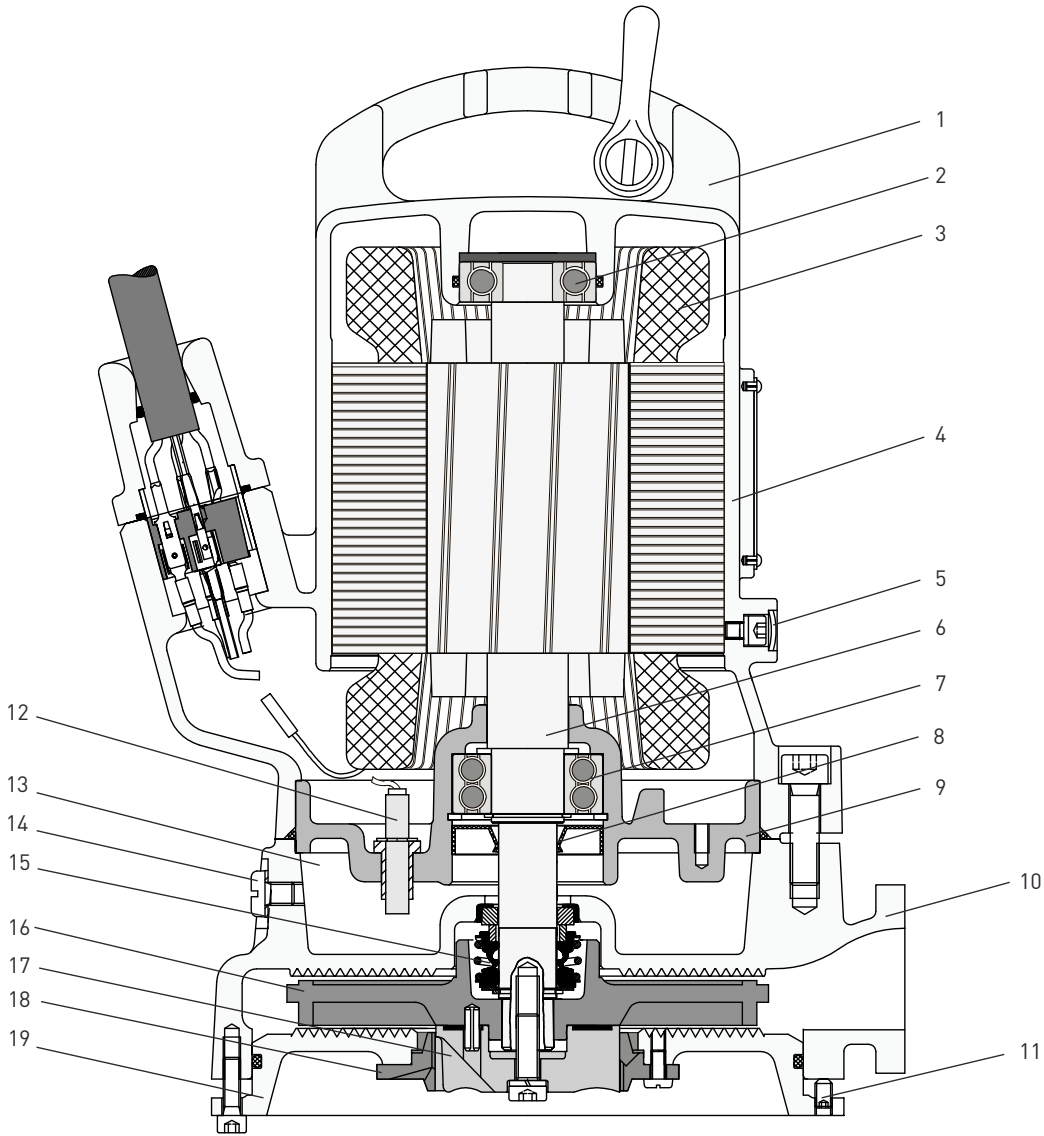

1233-00

Shredding system

- | | |
|----------------------------------------------|-----------------------------------------------|
| 1 Cast iron lifting handle and steel shackle | 11 Bottom plate adjustment screw |
| 2 Upper bearing - single row | 12 Moisture sensor (DI) |
| 3 Motor with thermal sensors | 13 Oil chamber |
| 4 Motor housing | 14 Oil chamber drain plug/pressure test point |
| 5 Motor chamber pressure test point | 15 Mechanical seal |
| 6 Stainless steel shaft | 16 Impeller |
| 7 Lower bearing - double row | 17 Shredding rotor |
| 8 Oil-lubricated lip seal | 18 Cutting ring (fixed to bottom plate) |
| 9 Bearing housing | 19 Bottom plate |
| 10 Volute | |

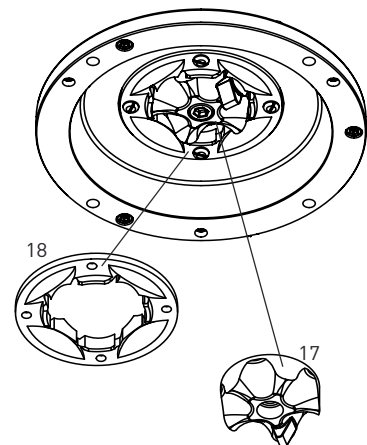

1234-00

4.2 Design features Piranha-PE

Submersible grinder pump fitted with a shredding system hydraulic and a Premium Efficiency motor.

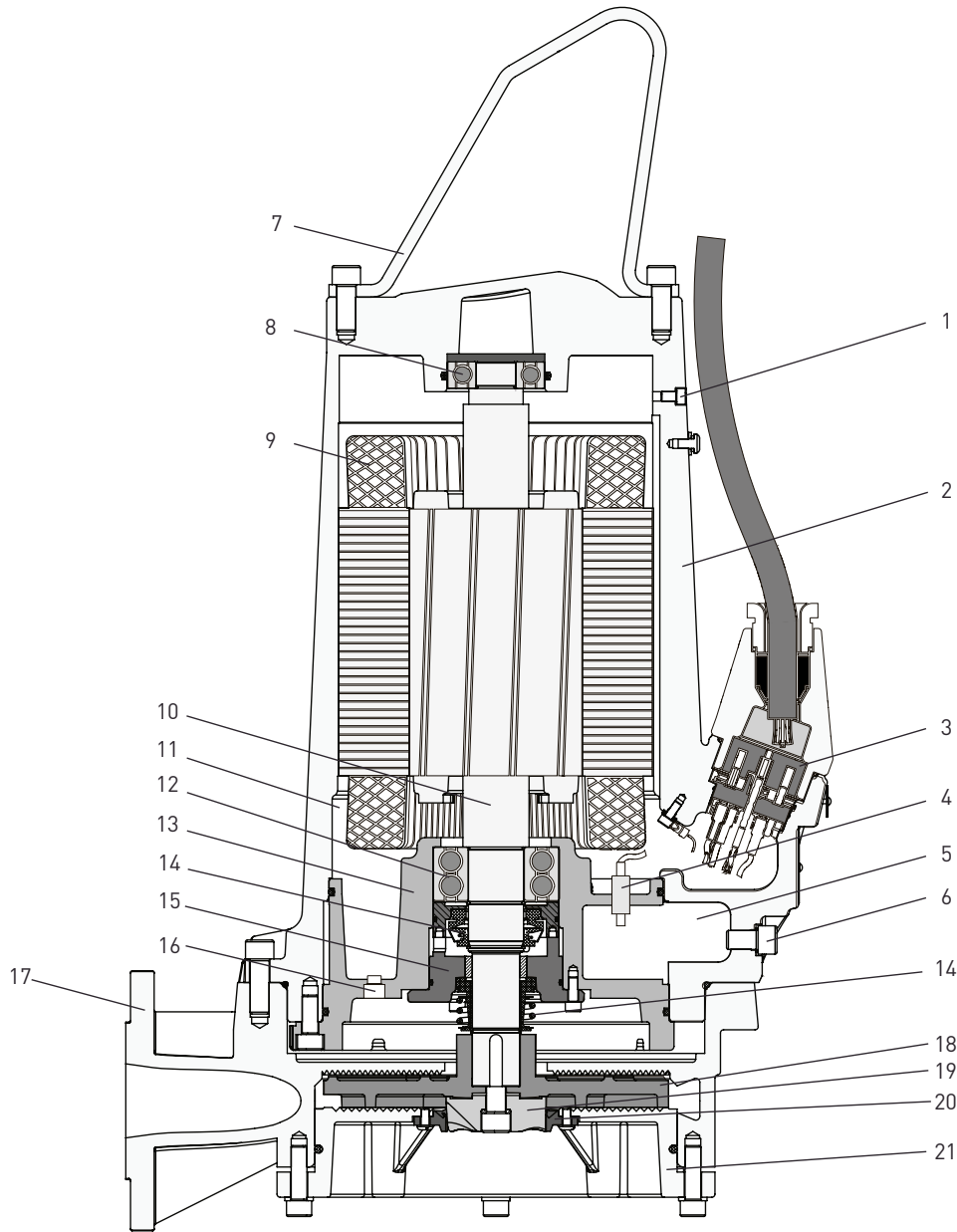

1235-00

Shredding system

- | | |
|----------------------------------------------|-----------------------------------------------|
| 1 Cast iron lifting handle and steel shackle | 11 Bottom plate adjustment screw |
| 2 Upper bearing - single row | 12 Moisture sensor (DI) |
| 3 Motor with thermal sensors | 13 Oil chamber |
| 4 Motor housing | 14 Oil chamber drain plug/pressure test point |
| 5 Motor chamber pressure test point | 15 Mechanical seal |
| 6 Stainless steel shaft | 16 Impeller |
| 7 Lower bearing - double row | 17 Shredding rotor |
| 8 Oil-lubricated lip seal | 18 Cutting ring (fixed to bottom plate) |
| 9 Bearing housing | 19 Bottom plate |
| 10 Volute | |

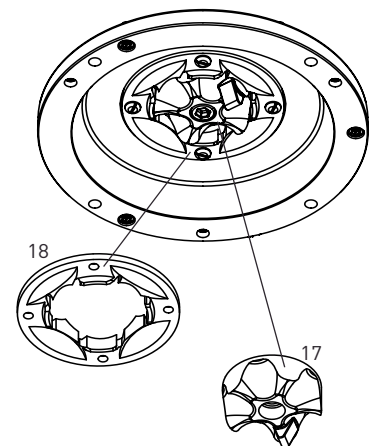

1234-00

5 Types of operation and frequency of starting

Pumps of the Piranha-PE series have been designed for continuous operation S1 when either submerged or dry-installed.

Piranha-S has been designed for intermittent use only (S3, 25%) when dry-installed, and continuous use (S1) when submerged, but only to the minimum water levels specified below.

Piranha-S	0530	0630	0631	0641	0830	0831	0840	0841
Minimum water level (mm)	331	348	346	346	408	445	379	450

6 Weights

NOTE: Weight on nameplate is for pump and cable only.

6.1 Piranha-PE

	Pedestal bracket and fasteners	Skirtbase (transportable)	Cable					Pump (without cable)	
			kg (lbs)						
Piranha	kg (lbs)	kg (lbs)	400 V ¹⁾	208 V ²⁾	230 V ²⁾	460 V ²⁾	600 V ²⁾	kg (lbs)	
50 Hz	S10 - S17	4 (9)	4 (9)	0.2 (0.4)	-	-	-	-	30 (66)
	S21	4 (9)	4 (9)	0.2 (0.4)	-	-	-	-	32 (71)
	S26	4 (9)	4 (9)	0.2 (0.4)	-	-	-	-	35 (77)
	PE 30/2D	4 (9)	4 (9)	0.3 (0.7)	-	-	-	-	82 (181)
	PE 55/2D,	7 (15)	4 (9)	0.4 (0.9)	-	-	-	-	122 (269)
	PE 70/2D	7 (15)	4 (9)	0.4 (0.9)	-	-	-	-	126 (278)
	PE 90/2D, PE 110/2D	7 (15)	4 (9)	0.4 (0.9)	-	-	-	-	148 (326)
60 Hz	S10 & S20	4 (9)	4 (9)	-	0.13 (0.29)	0.13 (0.29)	0.13 (0.29)	-	30 (66)
	S26	4 (9)	4 (9)	-	0.13 (0.29)	0.13 (0.29)	-	--	35 (77)
	S30	4 (9)	4 (9)	-	0.13 (0.29)	0.13 (0.29)	0.13 (0.29)	-	51 (112)
	PE 25/2W	4 (9)	4 (9)	-	0.18 (0.4)	0.18 (0.4)	-	-	77 (170)
	PE 28/2D	4 (9)	4 (9)	-	0.14 (0.3)	0.14 (0.3)	0.14 (0.3)	0.14 (0.3)	77 (170)
	PE 35/2W	4 (9)	4 (9)	-	0.23 (0.5)	0.23 (0.5)	-	-	77 (170)
	PE 35/2D	4 (9)	4 (9)	-	0.18 (0.4)	0.14 (0.3)	0.14 (0.3)	0.14 (0.3)	77 (170)
	PE 45/2W	4 (9)	4 (9)	-	0.23 (0.5)	0.23 (0.5)	-	-	80 (176)
	PE 45/2D	4 (9)	4 (9)	-	0.23 (0.5)	0.18 (0.4)	0.18 (0.4)	0.14 (0.3)	80 (176)
	PE 80/2D	7 (15)	4 (9)	-	0.23 (0.5)	0.23 (0.5)	0.18 (0.4)	0.14 (0.3)	124 (273)
	PE 100/2D,	7 (15)	4 (9)	-	0.23 (0.5)	0.23 (0.5)	0.23 (0.5)	0.18 (0.4)	153 (337)
	PE 110/2D	7 (15)	4 (9)	-	0.23 (0.5)	0.23 (0.5)	0.23 (0.5)	0.23 (0.5)	153 (337)
	PE 125/2D	7 (15)	4 (9)	-	0.23 (0.5)	0.23 (0.5)	0.23 (0.5)	0.23 (0.5)	153 (337)

¹⁾ Weight per metre. ²⁾ Weight per foot.

6.2 Chain (DIN 763)

Size (mm)	5 x 35	6 x 42	8 x 52	10 x 65	13 x 82
Weight per metre (kg)	0.43	0.63	1.10	1.75	2.95



Weights of accessories, other than or in addition to those listed, must also be included when specifying the working load of any lifting equipment. Please consult with your local Sulzer representative prior to installation.

7 Transport and storage

7.1 Transport

During transport, care should be taken that the pump is not dropped or thrown.

The unit is fitted with a lifting device to which a chain and shackle may be attached for transport purposes.



The unit should never be raised or lowered by the power cable.



Take note of the weight of the entire unit. The hoist and chain must be adequately dimensioned for that weight and must comply with the current valid safety regulations.

All relevant safety regulations as well as general good technical practice must be complied with.

7.2 Storage

1. During long periods of storage the pump should be protected from moisture and extremes of cold or heat.
2. To prevent the mechanical seals from sticking it is recommended that occasionally the impeller is rotated by hand.
3. If the pump is being taken out of service the oil should be changed before storage.
4. After storage the pump should be inspected for damage, the oil level should be checked, and the impeller checked to ensure it rotates freely.

7.2.1 Moisture protection of motor connection cable

The motor connection cables are protected against the ingress of moisture along the cable by having the ends sealed at the factory with protective covers.

ATTENTION! *The ends of the cables should never be immersed in water as the protective covers only provide protection against water spray or similar (IP44) and are not a water tight seal. The covers should only be removed immediately prior to connecting the pumps electrically.*

During storage or installation, prior to the laying and connection of the power cable, particular attention should be given to the prevention of water damage in locations which could flood.

ATTENTION! *If there is a possibility of water ingress then the cable should be secured so that the end is above the maximum possible flood level. Take care not to damage the cable or its insulation when doing this.*

8 Mounting and installation



The regulations covering the use of pumps in sewage applications together with all regulations involving the use of explosion-proof motors should be observed. The cable ducting to the control panel should be sealed off in a gas-tight manner by the use of a foaming material after the cable and control circuits have been pulled through. In particular the safety regulations covering work in enclosed areas in sewage plants should be observed together with general good technical practice.

For the Piranha transportable version, arrange the cable run so that the cables will not be kinked or nipped. Connect the discharge pipe and cable (see section "Electrical Connection"). Place the pump on a firm surface which will prevent it from overturning or burrowing down. The pump can also be bolted down to the base or suspended slightly by the lifting handle. Hoses, pipes and valves must be sized to suit the pump performance.

8.1 Installation example in concrete sump

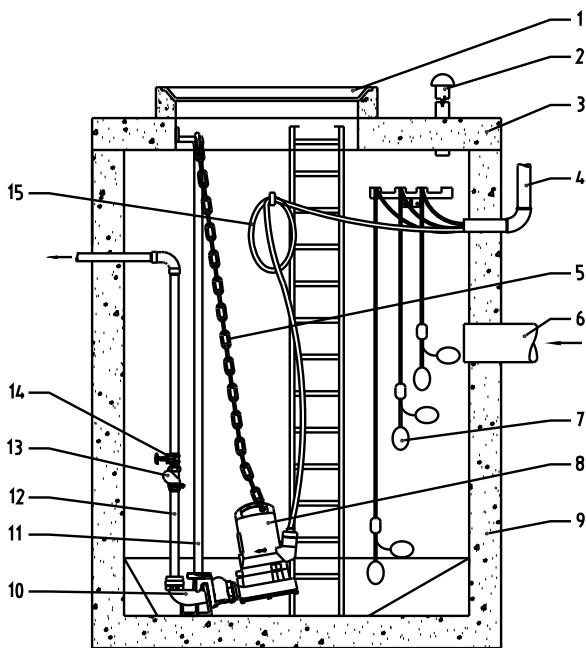

- | | |
|----|------------------------------------------------|
| 1 | Sump cover |
| 2 | Venting line |
| 3 | Sump cover |
| 4 | Protective duct to the control panel for cable |
| 5 | Chain |
| 6 | Inflow line |
| 7 | Ball type float switch |
| 8 | Submersible pump |
| 9 | Concrete sump |
| 10 | Pedestal |
| 11 | Guide tube* |
| 12 | Discharge line |
| 13 | Non-return valve |
| 14 | Gate valve |
| 15 | Power cable to motor |

1005-00

* The fitting of a guide tube is compulsory when the pump is installed on a pedestal.

ATTENTION For those applications subject to Regulation DIN 1986, a backwash loop should be provided in the discharge line.

8.2 Venting of the volute

After lowering the pump into a sump full of water, an air lock may occur in the volute and cause pumping problems. To clear the air lock, shake the pump, or raise the pump in the medium and then lower it again. If necessary, repeat this venting procedure.

8.3 Discharge line

The discharge line must be installed in compliance with the relevant regulations. DIN 1986/100 and EN 12056 applies in particular to the following:

- The discharge line should be fitted with a backwash loop (180° bend) located above the backwash level and should then flow by gravity into the collection line or sewer.
- The discharge line should not be connected to a down pipe.
- No other inflows or discharge lines should be connected to this discharge line.

ATTENTION! *The discharge line should be installed so that it is not affected by frost.*

The vent line is connected by means of a push-on sleeve to the vertical outlet at the top of the collection tank. It should be of constant cross-section (min. DN 70) and should have a continuous rise to above roof level.

9 Electrical connection



Before commissioning an expert should check that one of the necessary electrical protective devices is available. Earthing, neutral, earth leakage circuit breakers, etc. must comply with the regulations of the local electricity supply authority and a qualified person should check that these are in perfect order.

ATTENTION! *The power supply system on site must comply with local regulations with regard to cross-sectional area and maximum voltage drop. The voltage stated on the nameplate of the pump must correspond to that of the mains*

The power supply cable must be protected by an adequately dimensioned slow-blow fuse corresponding to the rated power of the pump.



The incoming power supply as well as the connection of the pump itself to the terminals on the control panel must comply with the circuit diagram of the control panel as well as the motor connection diagrams and must be carried out by a qualified person.

All relevant safety regulations as well as general good technical practice must be complied with.

ATTENTION! *For use in the open air, the following regulations apply:*

Submersible pumps used outdoors must be fitted with a power cable of at least 10 m length. Other regulations may apply in different countries.

In all installations, the power supply to the pump must be via a residual current device (e.g. RCD, ELCB, RCBO etc.) with a rated residual operating current not exceeding 30 mA. For installations not having a fixed residual current device the pump must be plugged into the power supply through a portable version of the device.

NOTE: *Please consult your electrician.*

9.1 Temperature monitoring

Thermal sensors in the stator windings protect the motor from overheating.

Piranha motors are fitted with bimetallic thermal sensors in the stator as standard in Piranha-PE and Ex Piranha-S, and as an option in non-Ex Piranha-S.

ATTENTION: *Explosion-proof pumps may only be used in explosive zones with the thermal sensors connected.*

9.2 Seal monitoring

Piranha-PE and Piranha-S pumps are supplied with a moisture sensor (DI), to detect and alert to the ingress of water into the motor and oil chambers.

DI is optional with Piranha-S, and in the Ex-version monitors only the motor chamber.

ATTENTION: *If the DI seal monitoring is activated the unit must be immediately taken out of service. Please contact your Sulzer Service Centre.*

NOTE! *Running the Piranha-PE pump with the thermal and/or moisture sensors disconnected will invalidate related warranty claims.*

9.3 Wiring diagrams

Single phase:

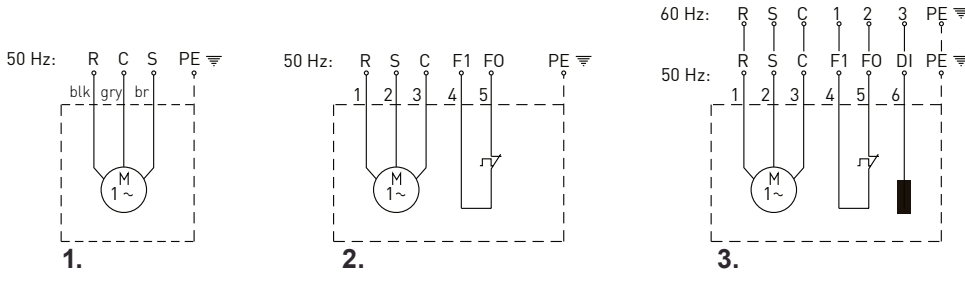

NOTE:
 R = Run
 S = Start
 C = Neutral (Common)
 F1, F0 = Thermal sensor
 DI = Seal monitor
 PE = Earth
 blk = Black
 gry = Grey
 br = Brown

1236-00

Three phase:

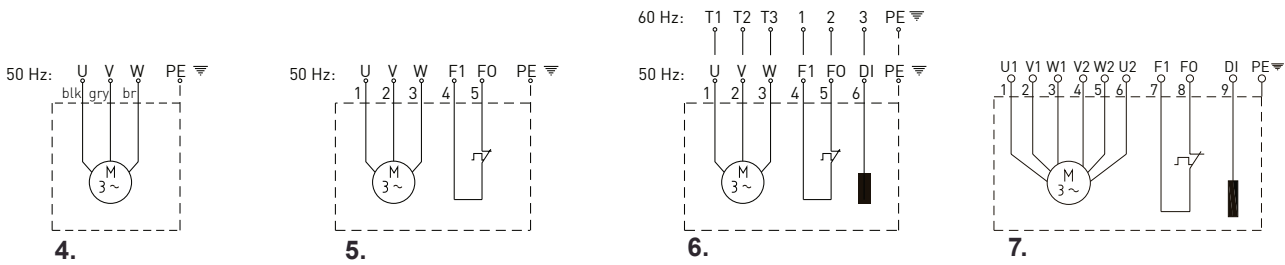

1237-00

	Single phase			Three phase			
	1.	2.	3.	4.	5.	6.	7.
Piranha 50 Hz	S10/4 S12/2 S17/2	S10/4-Ex S12/2-Ex S17/2-Ex	S10/4, S10/4-Ex, S12/2, S12/2-Ex, S17/2, S17/2-Ex	S13/4 S12/2 S17/2 S21/2 S26/2	S13/4-Ex S12/2-Ex S17/2-Ex S21/2-Ex S26/2-Ex	S13/4, S13/4-Ex, S12/2, S12/2-Ex, S17/2, S17/2-Ex, S21/2, S21/2-Ex, S26/2, S26/2 (DO5)* S26/2-Ex PE30/2C-Ex	PE55/2E-Ex PE70/2E-Ex PE90/2E-Ex PE110/2E-Ex
Piranha 60 Hz	-	-	S10/4, S10/4-Ex, S20/2, S20/2-Ex, S26/2, S26/2-Ex, PE25/2C-Ex ** PE35/2C-Ex ** PE45/2C-Ex **	-	-	S10/4, S10/4-Ex, S20/2, S20/2-Ex, S30/2, S30/2-Ex, PE28/2C-Ex ** PE35/2C-Ex ** PE45/2C-EX ** PE80/2E-EX ** PE100/2E-EX ** PE110/2E-EX ** PE125/2E-EX **	-

* 400/695V

** Non-Ex where CSA approved.

ATTENTION: It is important to use the correct capacitors with single phase pumps, use of incorrect capacitors will lead to motor burn-out.

9.4 Checking direction of rotation

When three phase units are being commissioned for the first time and also when used on a new site, the direction of rotation must be carefully checked by a qualified person.



When checking the direction of rotation, the unit should be secured in such a manner that no danger to personnel is caused by the rotating impeller, or by the resulting air flow. Do not place your hand into the hydraulic system!



When checking the direction of rotation, or when starting the unit, pay attention to the **START REACTION**. This can be very powerful and cause the pump to jerk in the opposite direction to the direction of rotation.

ATTENTION:

When viewed from above, the direction of rotation is correct if the impeller rotates in a clockwise manner.



NOTE:

The start reaction is anti-clockwise.

NOTE:

If a number of units are connected to a single control panel then each unit must be individually checked.

ATTENTION!

The mains supply to the control panel should have a clockwise rotation. If the leads are connected in accordance with the circuit diagram and lead designations, the direction of rotation will be correct.

9.5 Changing direction of rotation



The direction of rotation should only be altered by a qualified person.

If the direction of rotation is incorrect then this is altered by changing over two phases of the power supply cable in the control panel. The direction of rotation should then be rechecked

NOTE:

The direction of rotation measuring device monitors the direction of rotation of the mains supply or that of an emergency generator.

10 Commissioning



In explosive zones, care must be taken that during switching on and operation, the pump section is filled with water or alternatively is submerged or under water. Ensure that the minimum submergence given in the data sheet is observed. Other types of operation e.g. snore operation or dry running are not allowed.

Before commissioning the unit should be checked and a functional test carried out. Particular attention should be paid to the following:

- Have the electrical connections been carried out in accordance with regulations?
- Have the thermal sensors been connected?
- Is the seal monitoring device (where fitted) correctly installed?
- Is the motor overload switch correctly set?
- Have the power and control circuit cables been correctly fitted?
- Was the sump cleaned out?
- Have the inflow and outflows of the pump station been cleaned and checked?
- Is the direction of rotation correct - even if run via an emergency generator?
- Are the level controls functioning correctly?
- Are the required gates valves (where fitted) open?
- Do the non-return valves (where fitted) function easily?
- Has the volute been vented (see Sec. 8.2) ?

11 Maintenance and service



To avoid danger if the power cable is damaged, it must be replaced by the manufacturer or its service agent or a similarly qualified person.



Before commencing any maintenance work the unit should be completely disconnected from the mains by a qualified person and care should be taken that it cannot be inadvertently switched back on.



Servicing must only be carried out by qualified personnel.



When carrying out any repair or maintenance work, the safety regulations covering work in enclosed areas of sewage installations as well as good general technical practices should be followed.

NOTE

The maintenance instructions given here are not designed for “do-it-yourself” repairs as special technical knowledge is required.

11.1 General maintenance hints

Sulzer submersible pumps are reliable quality products, each being subjected to careful final inspection. Lubricated-for-life ball bearings, together with monitoring devices, ensure optimum pump reliability provided that the pump has been connected and operated in accordance with the operating instructions. However, should a malfunction occur, do not improvise, but ask your Sulzer Customer Service Department for assistance. This applies particularly if the pump is continually switched off by the current overload in the control panel, by the thermal sensors of the thermo-control system, or by the seal monitoring system (DI).

Regular inspection and care is recommended to ensure a long service life. Service intervals vary for Piranha pumps depending on installation and application. For recommended service interval details contact your local Sulzer Service Centre. A maintenance contract with our Service Department will guarantee the best technical service.

When carrying out repairs, only original spare parts supplied by the manufacturer should be used. Sulzer warranty conditions are only valid provided that any repair work has been carried out in an Sulzer approved workshop and where original Sulzer spare parts have been used.

NOTE ***ATEX- and FM-rated Piranha pumps are approved for use in hazardous locations. If an Ex-rated pump is serviced or repaired in a workshop that is not Ex-approved then it must no longer be used in hazardous locations. In that case the Ex nameplate must be removed and replaced by the standard nameplate, or where instead a standard and a secondary Ex nameplate is fitted to the pump the secondary nameplate must be removed.***

11.2 Shredding system

The shredding system of the Piranha is a wearing part, and as such may need to be replaced. A reduction in cutting performance can reduce the output. We recommend that the shredding system is inspected regularly. This is particularly so if sewage containing sand is being pumped. Regular inspection and care is recommended to ensure a long service life.

The Sulzer Service Organisation would be pleased to advise you on any applications you may have and to assist you in solving your pumping problems.

11.3 Oil filling and changing

The motor chamber (Piranha-PE), and the oil chamber between the motor and the hydraulic section (Piranha-PE & Piranha-S), have been filled at manufacture.

An oil change is only necessary:

- at specified service intervals (for details contact your local Sulzer Service Centre).
- if the DI moisture sensor detects an ingress of water into the oil chamber or motor chamber.
- after repair work that requires draining of the oil.
- if the pump is being taken out of service the oil should be changed before storage.

11.3.1 Instructions on how to drain and fill the oil chamber

1. Loosen the plug screw enough to release any pressure that may have built-up, and re-tighten (for location see pages 6 and 7).



Before doing so, place a cloth over the plug screw to contain any possible spray of oil as the pump de-pressurises.

2. Place the pump in a horizontal position on a waste oil sump with the drain hole underneath.
3. Remove the plug screw and seal ring from the drain hole.
4. After the oil is fully drained rotate the pump so that the drain hole is positioned to the top.
5. Select the required volume from the oil-fill quantities table and slowly fill with oil into the drain hole.
6. Refit the plug screw and seal ring.

11.4 Oil-fill quantities

Piranha	Motor	Oil Chamber (litres)
S	S10/4 - S26/2	0.53
PE	PE30/2-C	0.43
	PE55/2-E - PE125/2-E	0.68

Specification

Piranha-S: white mineral VG15 FP175C

Piranha-PE: white mineral VG8 FP153C

11.5 Bearings and mechanical seals

Piranha pumps are fitted with lubricated-for-life ball bearings.

Shaft sealing is by means of double mechanical seals (Piranha-PE), and mechanical seal / lip seal (Piranha-S).

ATTENTION! *Once removed, bearings and seals must not be re-used, and must be replaced with genuine Sulzer spare parts in an approved workshop.*

11.6 Maintenance of lifting stations in accordance with EN 12056.

It is recommended that the lifting station be inspected monthly and its function checked.

In accordance with EN regulations, the lifting station should be maintained by a qualified person at the following intervals:

- in commercial premises - every three months.
- in apartment blocks - every six months.
- in a single family home - once a year.

In addition we recommend that a maintenance contract be taken out with a qualified company.

11.7 Cleaning

If the pump is used for transportable applications, then in order to avoid deposits of dirt and encrustation it should be cleaned after each usage by pumping clear water. In the case of fixed installation, we recommend that the functioning of the automatic level control system be checked regularly. By switching the selection switch (switch setting "HAND") the sump will be emptied. If deposits of dirt are visible on the floats then these should be cleaned. After cleaning, the pump should be rinsed out with clear water and a number of automatic pumping cycles carried out.

12 Troubleshooting guide

Fault	Cause	Fix
Pump does not run	Moisture sensor shutdown.	Check for loose or damaged oil plug, or locate and replace faulty mechanical seal / damaged o-rings. Change oil. ¹⁾
	Air lock in volute	Shake or raise and lower the pump repeatedly until resulting air bubbles no longer appear at surface level.
	Level control override.	Check for float switch that is faulty or tangled and held in OFF position in sump.
	Impeller jammed.	Inspect and remove jammed object. Check gap between impeller and bottom plate and adjust if necessary.
	Gate valve closed, non-return valve blocked.	Open gate valve, clean blockage from non-return valve.
Pump switching on/off intermittently	Temperature sensor shutdown.	Motor will restart automatically when pump cools down. Check thermal relay settings in control panel. Check for impeller blockage. If none of above, a service inspection is required. ¹⁾
Low head or flow	Wrong direction of rotation.	Change rotation by interchanging two phases of the power supply cable.
	Gap too wide between impeller and bottom plate	Reduce gap.
	Gate valve partially open.	Open valve fully.
Excessive noise or vibration	Defective bearing.	Replace bearing. ¹⁾
	Clogged impeller.	Remove and clean hydraulics.
	Wrong direction of rotation.	Change rotation by interchanging two phases of the power supply cable.



Before commencing any inspection or repair work the pump should be completely disconnected from the mains by a qualified person and care should be taken that it cannot be inadvertently switched back on.

¹⁾ Pump must be taken to approved workshop.

SERVICE LOG

Date	Hours of Operation	Comments	Sign

SERVICE LOG

Date	Hours of Operation	Comments	Sign

