

Technical Specification

883457\_7.0

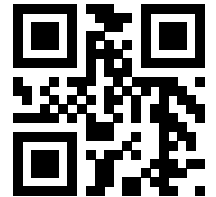
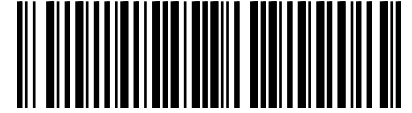

# Flygt 3315

50 HZ



# Table of Contents



1 N-pump.....	2
1.1 Product description.....	2
1.2 Motor rating and performance curves 3315.090/.095/.180/.185.....	5
1.3 Motor rating and performance curves 3315.660/670.....	8
2 Dimensions and Weight.....	11
2.1 Drawings.....	11

# 1 N-pump

## 1.1 Product description



### Usage

A submersible pump for efficient pumping of clean water, surface water, and wastewater containing solids or long-fibered material. The pump is designed for sustained high efficiency. Stainless steel N-impeller is available as an option.

### Denomination

Type	Non-explosion proof version	Explosion proof version	Pressure class	Installation types
Gray iron	3315.180	3315.090	LT – Low head MT – Medium head HT – High head	P, S, T, Z
Hard-Iron™	3315.185	3315.095	LT – Low head MT – Medium head HT – High head	P, S, T, Z
Stainless steel	3315.660	3315.670	LT – Low head MT – Medium head HT – High head	P, S

P Semipermanent, wet well arrangement with the pump installed on two guide bars. The connection to the discharge is automatic.

S Portable semipermanent, wet well arrangement with hose coupling or flange for connection to the discharge pipeline.

T Vertical permanent, dry well arrangement with flange connection to the suction and discharge piping.

Z Horizontal permanent, dry well arrangement with flange connection to the suction and discharge piping.

### Application limits

Feature	Description
Liquid temperature	Maximum 40°C (104°F)
Liquid temperature, warm water version	Maximum 70°C (158°F)
Depth of immersion	Maximum 20 m (65 ft)

Feature	Description
pH of the pumped liquid	5.5 - 14
Liquid density	Maximum 1100 kg/m <sup>3</sup>

### Motor data



Feature	Description
Motor type	Squirrel-cage induction motor
Frequency	50 Hz
Power supply	3-phase
Starting method	<ul style="list-style-type: none"> <li>• Direct on-line</li> <li>• Star-delta</li> <li>• Variable Frequency Drive (VFD)</li> </ul>
Number of starts per hour	Maximum 15
Code compliance	IEC 60034-1
Voltage variation	<ul style="list-style-type: none"> <li>• Continuously running: Maximum <math>\pm 10\%</math></li> <li>• Intermittent running: Maximum <math>\pm 10\%</math></li> </ul>
Voltage imbalance between phases	Maximum 2%
Stator insulation class	H (180°C, 356°F)

### Cables

Application	Type
Direct-on-line start or Y/D start with two cables	Flygt SUBCAB® - a heavy duty 4 cores motor power cable with two twisted pair screened control cores. Conductor insulation rating of 90°C, which allows for increased current. Superior mechanical strength and high abrasion and tear resistant. Chemical resistant within pH 3-10 and ozone, oil, and flame resistant. Used up to 70°C water temperature. Cables < 10 mm <sup>2</sup> with unscreened control cores.
Y/D start	Flygt SUBCAB® - a heavy duty 7 cores motor power cable with two twisted pair screened control cores. Conductor insulation rating of 90°C, which allows for increased current. Superior mechanical strength and high abrasion and tear resistant. Chemical resistant within pH 3-10 and ozone, oil, and flame resistant. Used up to 70°C water temperature. Cables < 7G6 mm <sup>2</sup> with unscreened control cores.
Variable Frequency drive	Screened Flygt SUBCAB® - a heavy duty 4 screened cores motor power cable with four twisted pair screened control cores. Conductor insulation rating of 90°C, which allows for increased current. Superior mechanical strength and high abrasion and tear resistant. Chemical resistant within pH 3-10 and ozone, oil, and flame resistant. Used up to 70°C water temperature.

### Monitoring equipment

Thermal contacts opening temperature 140°C (284°F)

Leakage sensor in the inspection chamber (FLS10)

### Materials

Denomination	Material	ASTM	EN
Major castings	Cast iron, gray	35B	GJL-250



Denomination	Material	ASTM	EN
Pump housing	Cast iron, gray	35B	GJL-250
Impeller, alternative 1	Cast iron, gray	35B	GJL-250
Impeller, alternative 2	Stainless steel, Duplex	CD-4MCuN	10283:2010 -1.4474
Impeller, alternative 3	Hard-Iron™	A 532 – Alloy IIIA	12513-JN 3049
Insert ring, alternative 1	Cast iron, gray	35B	GJL-250
Insert ring, alternative 2	Hard-Iron™	A 532 – Alloy IIIA	12513-JN 3049
Cooling jacket, inner	Steel	A572 Grade 60	1.0045, 1.0553, ...
Cooling jacket, outer	Stainless steel	AISI 316L	1.4404
Lifting handle	Stainless steel	AISI 316L	1.4404
Shaft	Stainless steel	AISI 431	1.4057
Screws and nuts	Stainless steel, A4	AISI 316L	1.4404
O-rings	Nitrile rubber (NBR) 70° IRH	-	-
O-rings	Fluorinated rubber (FPM) 70° IRH	-	-
Glycol	Heat transfer fluid based on monopropylene glycol.	-	-

If the impeller material is Hard-Iron™, then the insert ring must also be Hard-Iron™.

Table 1: Mechanical seals

Alternative	Inner seal	Outer seal
1	Corrosion resistant cemented carbide (WCCR)/ Corrosion resistant cemented carbide (WCCR)	Corrosion resistant cemented carbide (WCCR)/ Corrosion resistant cemented carbide (WCCR)
2	Corrosion resistant cemented carbide (WCCR)/ Corrosion resistant cemented carbide (WCCR)	Silicon carbide (RSiC)/ Silicon carbide (RSiC)

### Surface treatment

Priming	Finish
Painted with a primer, see internal standard M0700.00.0002	Navy gray color NCS 5804-B07G. Two-component high-solid top coating, see internal standard M0700.00.0004 for standard painting and M0700.00.0008 for special painting.

### Options

- Warm liquid version (non-explosion proof versions)
- Sensors: Thermistor, FLS, Pt100, VIS 10
- Pump memory
- Surface treatment (Epoxy)
- Zinc anodes
- Other cables

### Accessories

Discharge connections, adapters, hose connections, and other mechanical accessories

Electrical accessories such as pump controller, control panels, starters, monitoring relays, cables

## 1.2 Motor rating and performance curves 3315.090/.095/.180/.185

These are examples of motor rating and curves. For more information, please contact your local sales and service representative.

Star-delta starting current is 1/3 of Direct on-line starting current.

LT

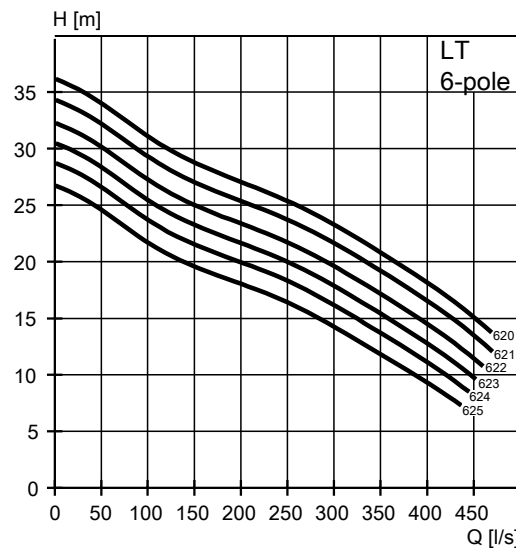
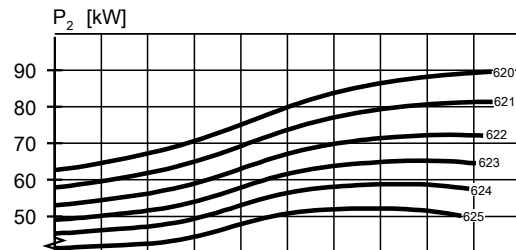

WS004524A

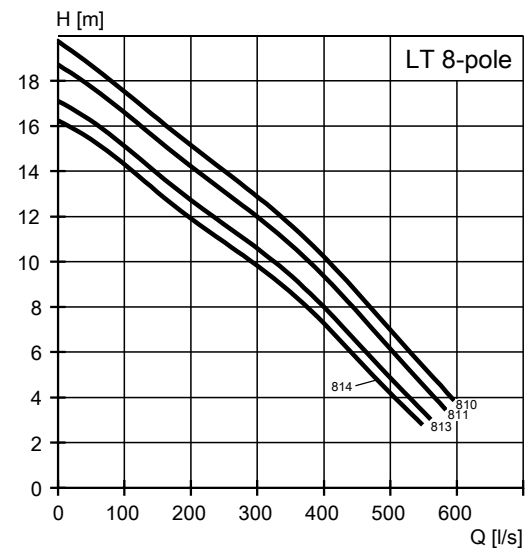
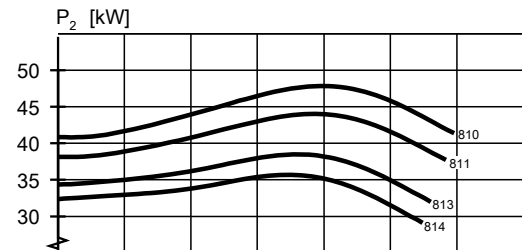

WS004525A

Table 2: 400 V, 50 Hz, 3-phase

Rated power, kW	Rated power, hp	Curve/ Impeller No	Revolutions per minute, rpm	Rated current, A	Starting current, A	Power factor, $\cos\phi$	Installation
48	64	811	735	102	525	0.75	P,T,Z
48	64	812	735	102	525	0.75	P,T,Z
48	64	813	735	102	525	0.75	P,T,Z
48	64	814	735	102	525	0.75	P,T,Z
62	83	810	735	124	660	0.79	P,T,Z
62	83	811	735	124	660	0.79	P,T,Z
62	83	812	735	124	660	0.79	P,T,Z
62	83	813	735	124	660	0.79	P,T,Z
62	83	814	735	124	660	0.79	P,T,Z
75	101	622	985	150	835	0.79	P,S,T,Z
75	101	623	985	150	835	0.79	P,S,T,Z
75	101	624	985	150	835	0.79	P,S,T,Z



Rated power, kW	Rated power, hp	Curve/ Impeller No	Revolutions per minute, rpm	Rated current, A	Starting current, A	Power factor, cosφ	Installation
75	101	625	985	150	835	0.79	P,S,T,Z
90	121	620	985	185	1160	0.76	P,S,T,Z
90	121	621	985	185	1160	0.76	P,S,T,Z
90	121	622	985	185	1160	0.76	P,S,T,Z
90	121	623	985	185	1160	0.76	P,S,T,Z
90	121	624	985	185	1160	0.76	P,S,T,Z
90	121	625	985	185	1160	0.76	P,S,T,Z

MT

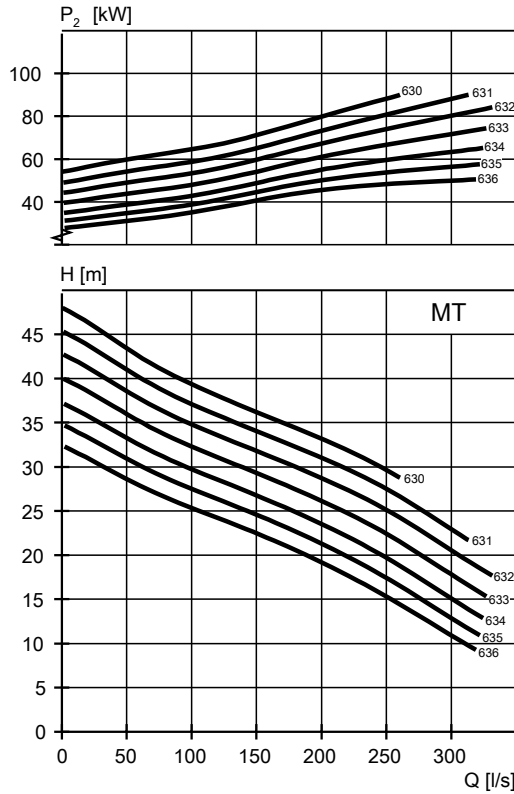

WS004526A

Table 3: 400 V, 50 Hz, 3-phase

Rated power, kW	Rated power, hp	Curve/ Impeller No	Revolutions per minute, rpm	Rated current, A	Starting current, A	Power factor, cosφ	Installation
75	101	632	985	150	835	0.79	P,S,T,Z
75	101	633	985	150	835	0.79	P,S,T,Z
75	101	634	985	150	835	0.79	P,S,T,Z
75	101	635	985	150	835	0.79	P,S,T,Z
75	101	636	985	150	835	0.79	P,S,T,Z
90	121	630	985	185	1160	0.76	P,S,T,Z
90	121	631	985	185	1160	0.76	P,S,T,Z
90	121	632	985	185	1160	0.76	P,S,T,Z
90	121	633	985	185	1160	0.76	P,S,T,Z



Rated power, kW	Rated power, hp	Curve/ Impeller No	Revolutions per minute, rpm	Rated current, A	Starting current, A	Power factor, $\cos\phi$	Installation
90	121	634	985	185	1160	0.76	P,S,T,Z
90	121	635	985	185	1160	0.76	P,S,T,Z
90	121	636	985	185	1160	0.76	P,S,T,Z

HT

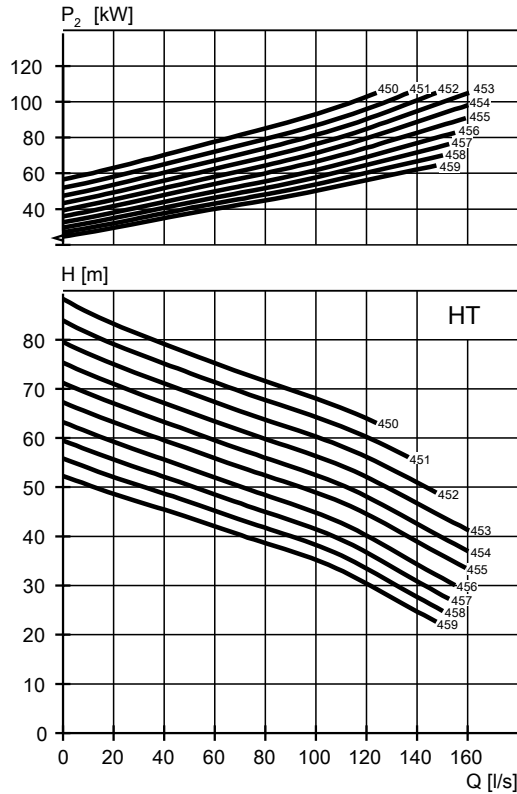

WS004527A

Table 4: 400 V, 50 Hz, 3-phase

Rated power, kW	Rated power, hp	Curve/ Impeller No	Revolutions per minute, rpm	Rated current, A	Starting current, A	Power factor, $\cos\phi$	Installation
85	114	453	1475	159	710	0.83	P,S,T,Z
85	114	454	1475	159	710	0.83	P,S,T,Z
85	114	455	1475	159	710	0.83	P,S,T,Z
85	114	456	1475	159	710	0.83	P,S,T,Z
85	114	457	1475	159	710	0.83	P,S,T,Z
85	114	458	1475	159	710	0.83	P,S,T,Z
85	114	459	1475	159	710	0.83	P,S,T,Z
105	141	450	1480	199	1105	0.81	P,S,T,Z
105	141	451	1480	199	1105	0.81	P,S,T,Z
105	141	452	1480	199	1105	0.81	P,S,T,Z
105	141	453	1480	199	1105	0.81	P,S,T,Z
105	141	454	1480	199	1105	0.81	P,S,T,Z
105	141	455	1480	199	1105	0.81	P,S,T,Z



Rated power, kW	Rated power, hp	Curve/ Impeller No	Revolutions per minute, rpm	Rated current, A	Starting current, A	Power factor, cosφ	Installation
105	141	456	1480	199	1105	0.81	P,S,T,Z
105	141	457	1480	199	1105	0.81	P,S,T,Z
105	141	458	1480	199	1105	0.81	P,S,T,Z
105	141	459	1480	199	1105	0.81	P,S,T,Z

### 1.3 Motor rating and performance curves 3315.660/670

These are examples of motor rating and curves. For more information, please contact your local sales and service representative.

Star-delta starting current is 1/3 of Direct on-line starting current.

LT

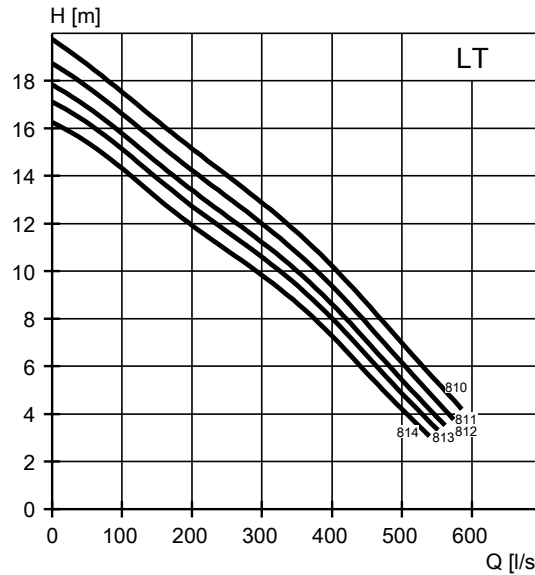
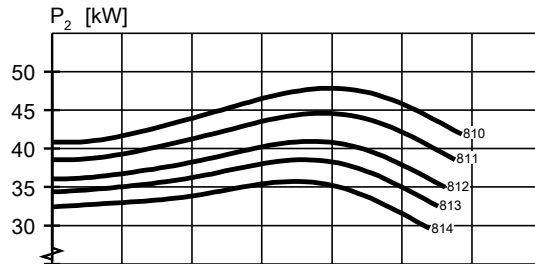

WS007746A

Table 5: 400 V, 50 Hz, 3-phase

Rated power, kW	Rated power, hp	Curve/ Impeller No	Revolutions per minute, rpm	Rated current, A	Starting current, A	Power factor, cos φ	Installation
48	64	811	735	102	545	0.75	P,T,Z
48	64	812	735	102	545	0.75	P,T,Z
48	64	813	735	102	545	0.75	P,T,Z
48	64	814	735	102	545	0.75	P,T,Z
62	83	810	735	124	660	0.79	P,T,Z
62	83	811	735	124	660	0.79	P,T,Z

MT

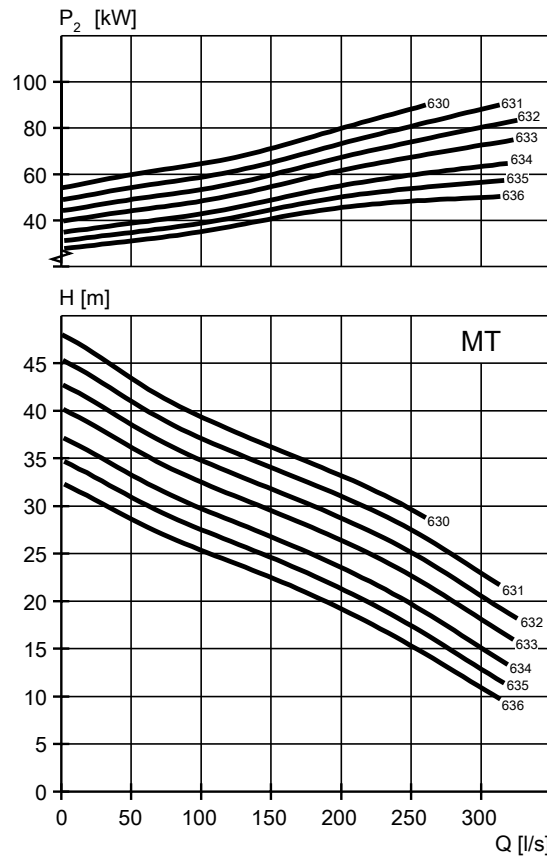

WS007747A

Table 6: 400 V, 50 Hz, 3-phase

Rated power, kW	Rated power, hp	Curve/ Impeller No	Revolutions per minute, rpm	Rated current, A	Starting current, A	Power factor, $\cos \varphi$	Installation
75	101	632	985	150	935	0.79	P,S,T,Z
75	101	633	985	150	935	0.79	P,S,T,Z
75	101	634	985	150	935	0.79	P,S,T,Z
75	101	635	985	150	935	0.79	P,S,T,Z
75	101	636	985	150	935	0.79	P,S,T,Z
90	121	630	985	185	1170	0.76	P,S,T,Z
90	121	631	985	185	1170	0.76	P,S,T,Z
90	121	632	985	185	1170	0.76	P,S,T,Z
90	121	633	985	185	1170	0.76	P,S,T,Z

HT

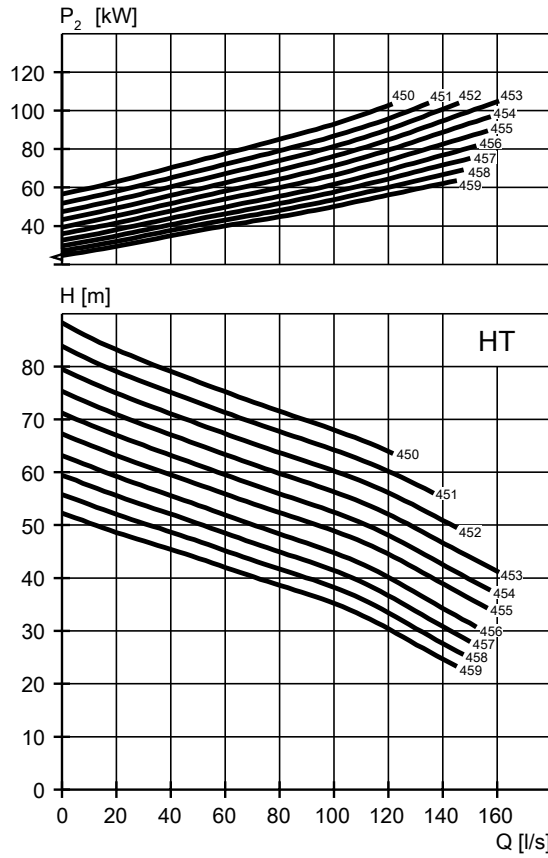

WS007745A

Table 7: 400 V, 50 Hz, 3-phase

Rated power, kW	Rated power, hp	Curve/ Impeller No	Revolutions per minute, rpm	Rated current, A	Starting current, A	Power factor, cos φ	Installation
85	114	453	1475	159	690	0.83	P,S,T,Z
85	114	454	1475	159	690	0.83	P,S,T,Z
85	114	455	1475	159	690	0.83	P,S,T,Z
85	114	456	1475	159	690	0.83	P,S,T,Z
85	114	457	1475	159	690	0.83	P,S,T,Z
85	114	458	1475	159	690	0.83	P,S,T,Z
85	114	459	1475	159	690	0.83	P,S,T,Z
105	141	450	1480	199	1105	0.81	P,S,T,Z
105	141	451	1480	199	1105	0.81	P,S,T,Z
105	141	452	1480	199	1105	0.81	P,S,T,Z
105	141	453	1480	199	1105	0.81	P,S,T,Z
105	141	454	1480	199	1105	0.81	P,S,T,Z
105	141	455	1480	199	1105	0.81	P,S,T,Z

# 2 Dimensions and Weight

## 2.1 Drawings

All drawings are available as Acrobat documents (.pdf) and AutoCad drawings (.dwg). Contact a local sales and service representative for more information.

All dimensions are in mm.

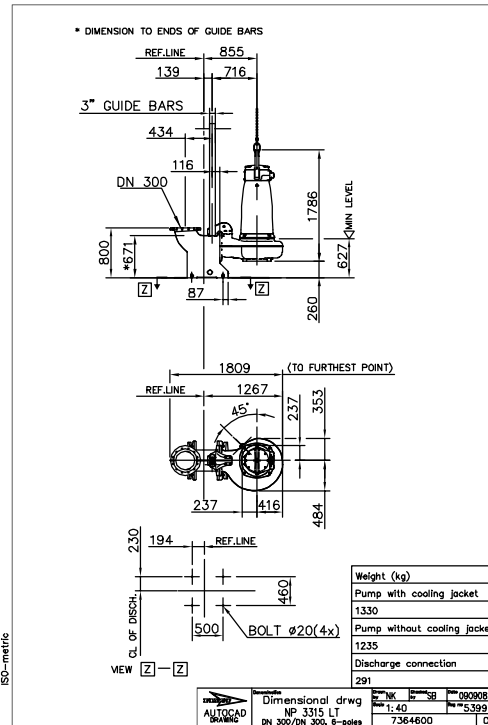

Figure 1: LT, P-installation

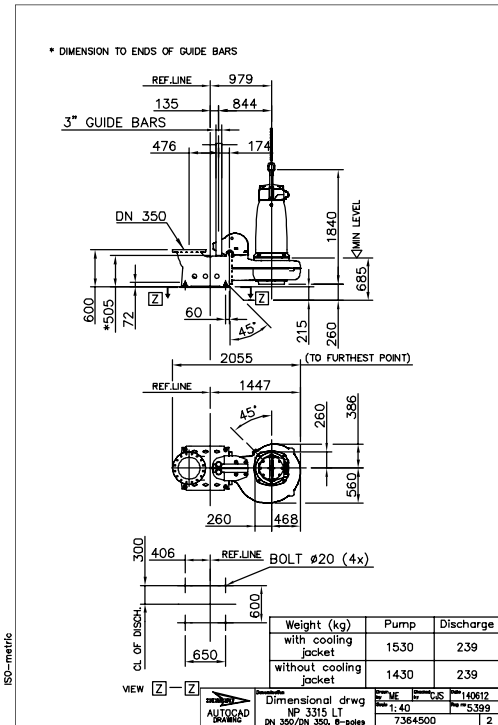

Figure 2: LT, P-installation



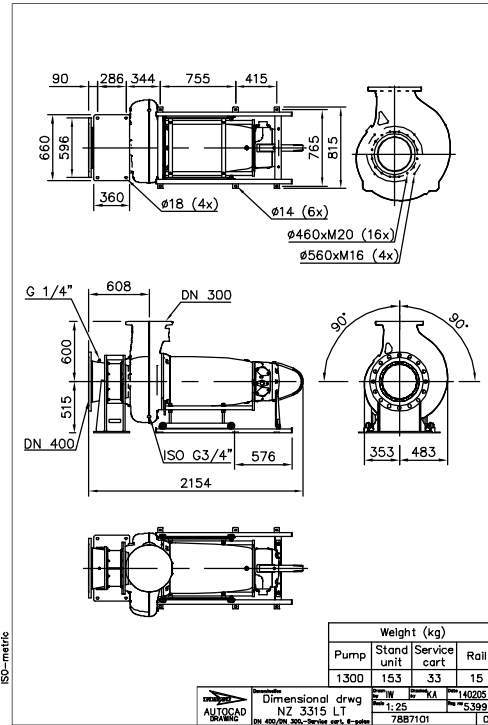

Figure 7: LT, Z-installation

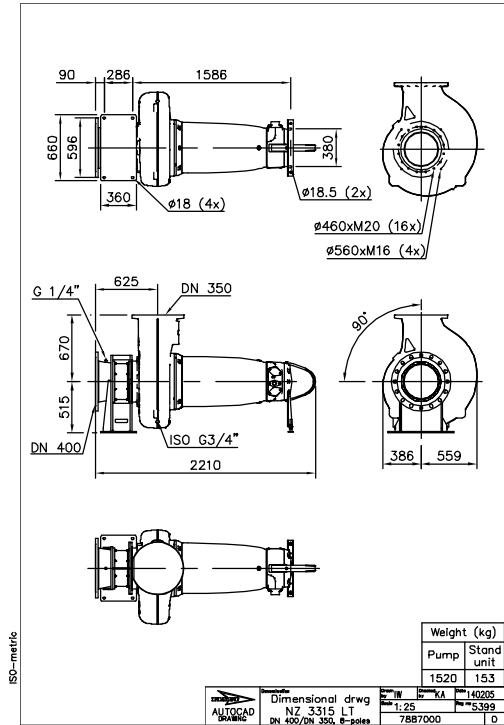

Figure 8: LT, Z-installation

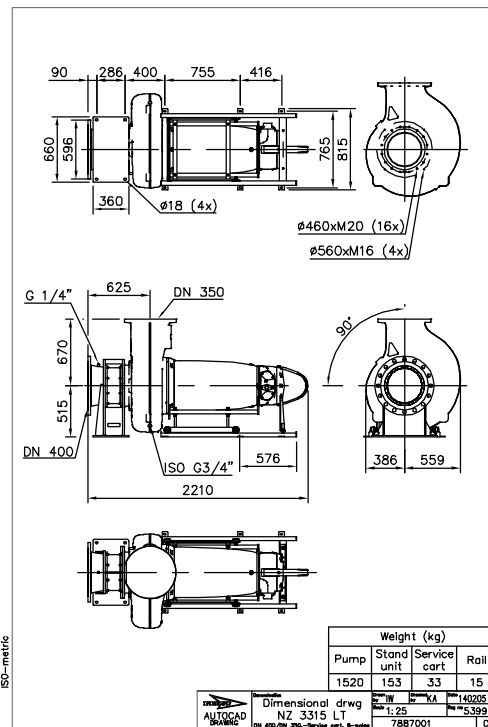

Figure 9: LT, Z-installation

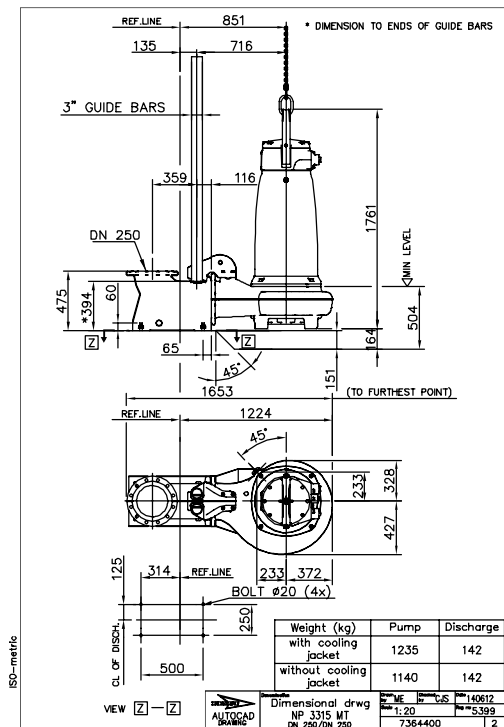

Figure 10: MT, P-installation

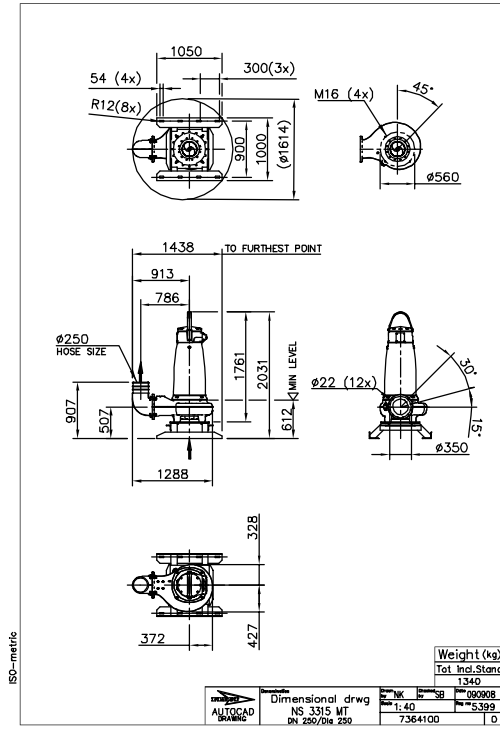

Figure 11: MT, S-installation

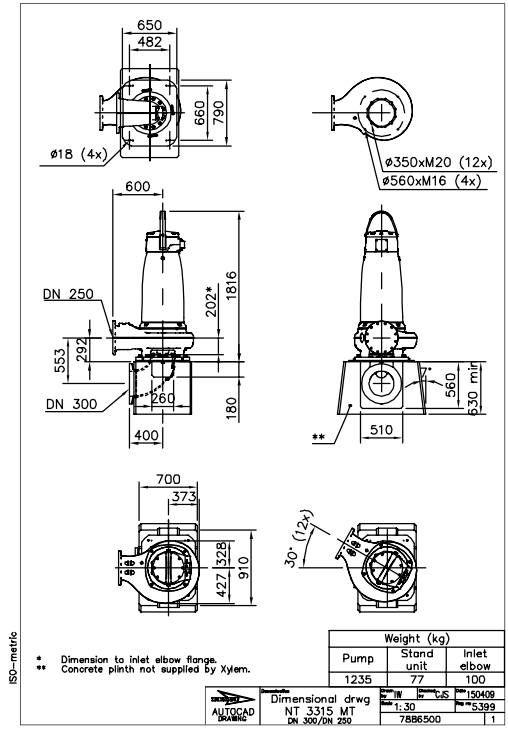

Figure 12: MT, T-installation

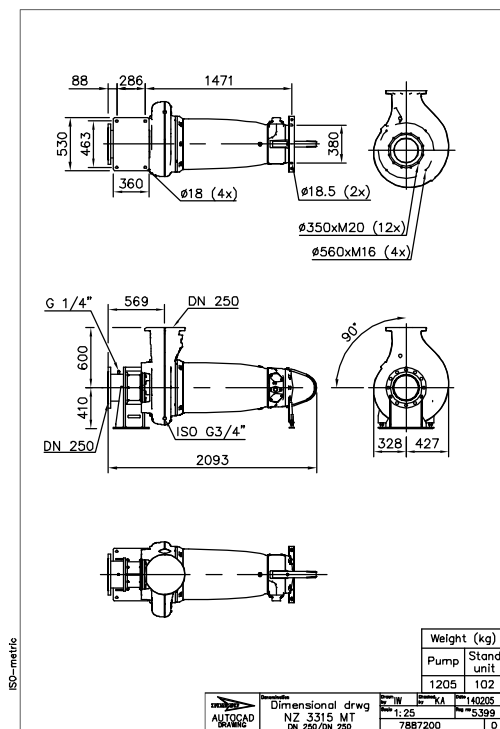

Figure 13: MT, Z-installation

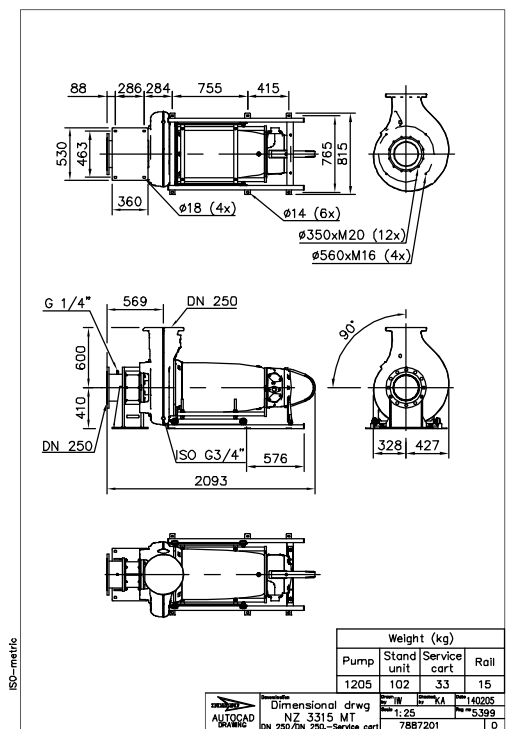

Figure 14: MT, Z-installation



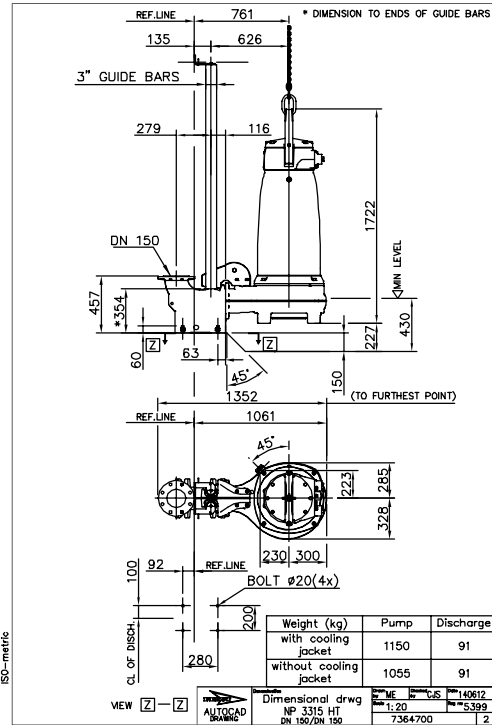

Figure 15: HT, P-installation

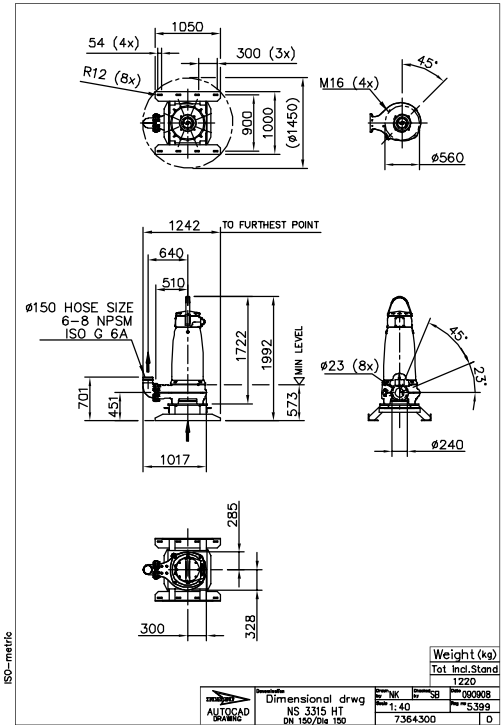

Figure 16: HT, S-installation

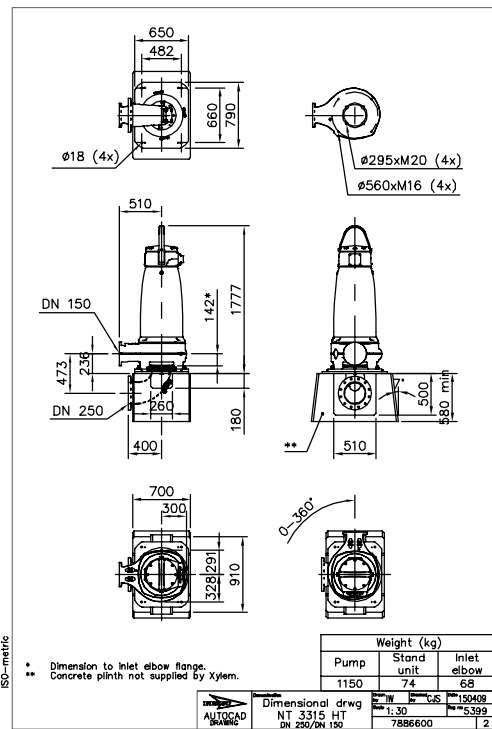

Figure 17: HT, T-installation

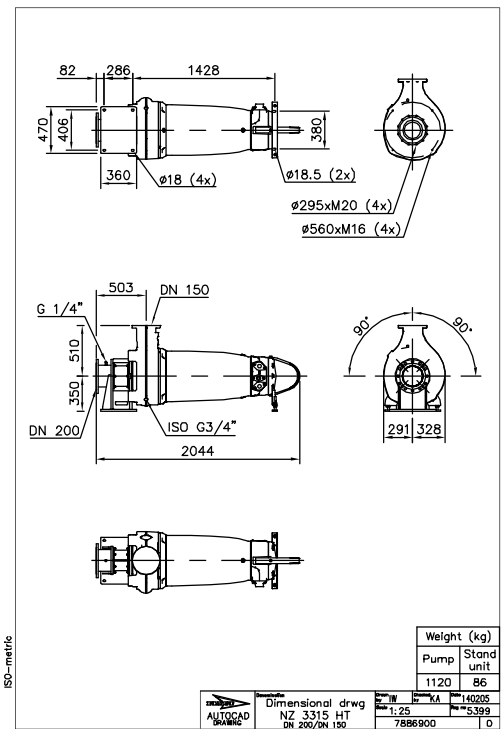

Figure 18: HT, Z-installation

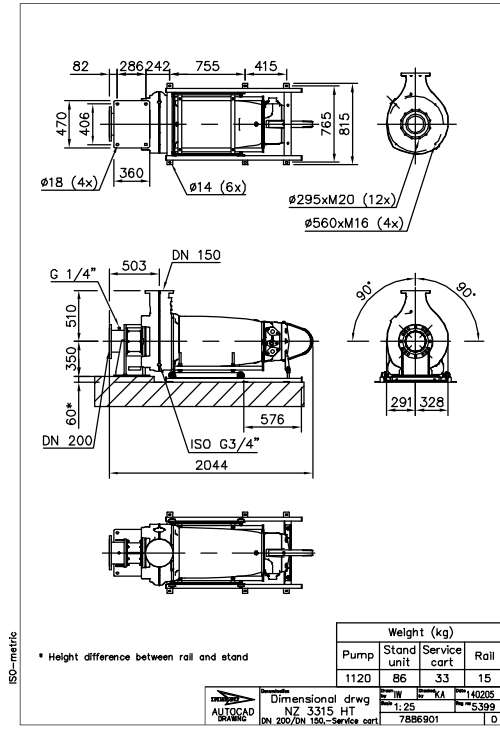

Figure 19: HT, Z-installation



# Xylem |'zīləm|

- 1) The tissue in plants that brings water upward from the roots;
- 2) a leading global water technology company.

We're a global team unified in a common purpose: creating advanced technology solutions to the world's water challenges. Developing new technologies that will improve the way water is used, conserved, and re-used in the future is central to our work. Our products and services move, treat, analyze, monitor and return water to the environment, in public utility, industrial, residential and commercial building services settings. Xylem also provides a leading portfolio of smart metering, network technologies and advanced analytics solutions for water, electric and gas utilities. In more than 150 countries, we have strong, long-standing relationships with customers who know us for our powerful combination of leading product brands and applications expertise with a strong focus on developing comprehensive, sustainable solutions.

For more information on how Xylem can help you, go to [www.xylem.com](http://www.xylem.com)



Xylem Water Solutions Global  
Services AB  
361 80 Emmaboda  
Sweden  
Tel: +46-471-24 70 00  
Fax: +46-471-24 74 01  
<http://tpi.xylem.com>  
[www.xylemwatersolutions.com/  
contacts/](http://www.xylemwatersolutions.com/contacts/)

Visit our Web site for the latest version of this document and more information

The original instruction is in English. All non-English instructions are translations of the original instruction.

© 2012 Xylem Inc