

**Floodable sewage disposal unit
 with integrated swing check valve**

Sanistar



Application

HOMA Sanistar are compact sewage disposal units. They are suitable for pumping sewage and waste water from toilets, hand basins, showers and rooms which are below the sewer level. Even if there is a natural fall, if the sewer is flooded, the sewage is unable to drain. In this case, Sanistar will prevent a back up and flooding of the room. HOMA Sanistar are the ideal solution for new constructions or renovation of old constructions.

They are used for applications in:

- Detached houses
- basement rooms
- sanitary facilities in cellar rooms
- sanitary facilities in restaurants, hotels, cinemas, theaters, shopping centers, schools and hospitals.

DIN EN 12050-1: Design tested and monitored.

Pumped medium: Clean water and waste water with solid and fibrous content and feces.

Max. temperature of pumped medium: 35° C, for brief periods up to 60° C.

Operating mode: Intermittent operation.

Design

Flood protected single or twin pump lifting station consisting of:

Collecting tank: Odour and gas-tight plastic collecting tank.

Inlets:

- DN 100 horizontal, 180 mm height
- DN 100 horizontal, 250 mm height
- DN 100 vertical
- DN 150 horizontal and vertical
- DN 40 vertical.

Discharge: Flange DN 80.

Flexible union piece DN 80/DN 100. With integrated soft ball check valve.

Air vent: DN 70 vertical.

Connection for diaphragm pump: BSP 1" F .

Cleaning cover with screw cap.

Pump: Pump chamber integrated in the collecting tank. Non clogging impeller, spherical clearance 45 mm.

Motor: Fully submersible motor, sealed against pressurized water, single phase or three phase version. Thermal sensor for temperature monitoring in the winding. Insulation class H, Protection rating IP 68. Chrome steel motor shaft, pre-lubricated bearings.

Seal: Triple radial seal in separate oil chamber, oil control possible from the outside.

Materials

Collecting tank with pump housing	Polyethylen
Impeller, pressurized lid	Cast iron EN-GJL-250
Motor shaft, screws	Stainless steel
Elastomers	NBR

Scope of supply

Tank with 1 pump (Sanistar 1...) or 2 pumps (Sanistar 2...), discharge with DN 80 soft ball check valve and flanged elastic union piece DN 80/DN 100 with hose bands. Elastic union piece for inlet DN 100 and air vent DN 70 with hose bands. Pneumatic level switch. Electronic control unit with mains cable and safety plug (1-Ph) or CEE-plug 16 A (3-Ph).

Control box

Pneumatic level control with pressure operation. Motor over run period which prevents sewage build up and blockage. Electronic control box for control and monitoring of all important functions. Motor protection with temperature control of the winding. Optical failure alarm. Acoustic alarm by buzzer. Volt free contact for remote signal. Control indication for direction of rotation. Connection for ServCom controller (see accessories) for:



- Monitoring of operation hours, number of starts, maintenance interval, abnormal operating conditions.
- Adjustment of pump operation level in the tank.

Mains-independent alarm by installing a 9 V battery (see accessories). Also available with PCM control (on request).

Additional for twin pump station:

Auto-change over after each pump cycle. Operation of both pumps at high flow. In the event of failure automatic change over to the second pump.

Conveying capacities

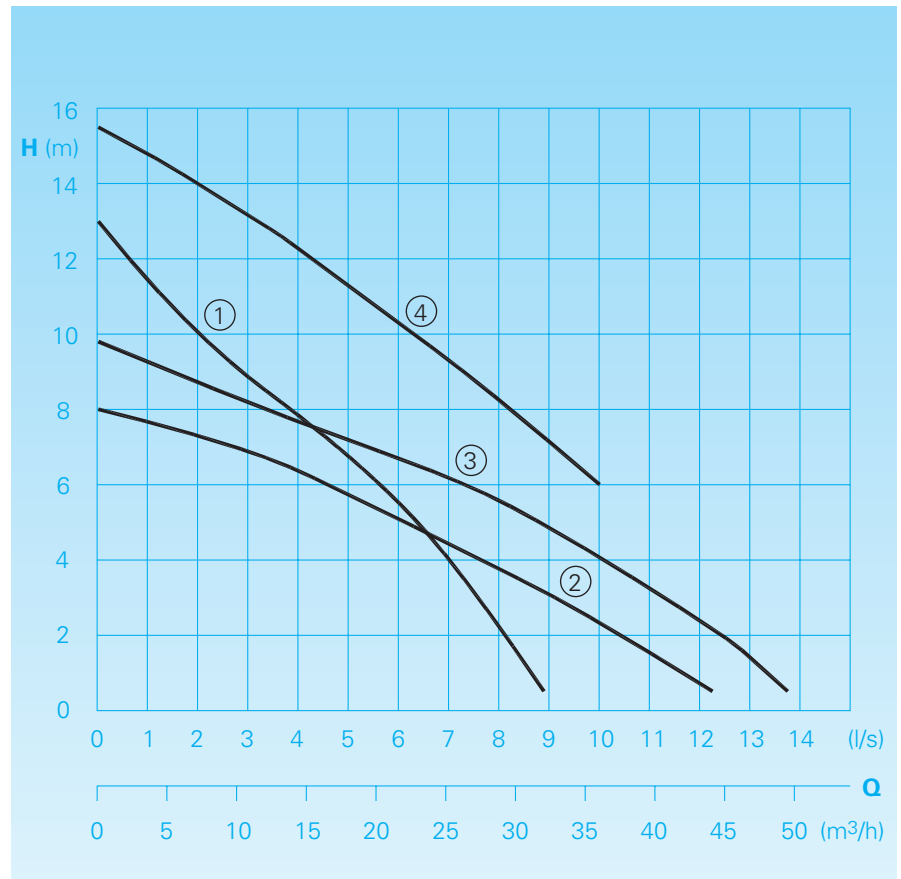

Connecting cable	Type	Length
Unit-control box	H07RN8-F 6G1,5	4 m
Control box plug	H07RN8-F 5G1,5	0,8 m

Technical data

Curve No.	Type Sanistar	No. of pumps	Motor input P ₁ (kW) P ₂ (kW)	Voltage 50 Hz (V)	Rotat. speed (rpm)	Nominal current (A)	Collecting tank total volume	Collecting tank operation vol.	Weight (kg)
①	105 W	1	1,6 1,1	230/1Ph	2900	7,0	70 l	30 l	64
①	105 D	1	1,5 1,1	400/3Ph	2900	2,5	70 l	30 l	64
②	110 W	1	1,7 1,3	230/1Ph	1450	7,1	70 l	30 l	66
②	110 D	1	1,5 1,1	400/3Ph	1450	3,1	70 l	30 l	66
③	120 W	1	2,3 1,7	230/1Ph	1450	10,7	70 l	30 l	73
③	120 D	1	2,3 1,7	400/3Ph	1450	4,4	70 l	30 l	73
④	130 D	1	3,0 2,1	400/3Ph	2900	5,1	70 l	30 l	73
①	205 W	2	1,6 1,1	230/1Ph	2900	7,0	95 l	45 l	92
①	205 D	2	1,5 1,1	400/3Ph	2900	2,5	95 l	45 l	92
②	210 W	2	1,7 1,3	230/1Ph	1450	7,1	95 l	45 l	96
②	210 D	2	1,5 1,1	400/3Ph	1450	3,1	95 l	45 l	96
③	220 W	2	2,3 1,7	230/1Ph	1450	10,7	95 l	45 l	110
③	220 D	2	2,3 1,7	400/3Ph	1450	4,4	95 l	45 l	110
④	230 D	2	3,0 2,1	400/3Ph	2900	5,1	95 l	45 l	110

The types Sanistar 210 to 230 are also available with 1 pump to allow a later installation of the second pump.

Inlets: DN 100 (3x), DN 150 (2x), DN 40 | **Discharge:** Flange DN 80 / EU-piece DN 80 / DN 100

Air vent: DN 70 / Connection for diaphragm pump BSP 1" F

Installation example

Main inlet
vertical

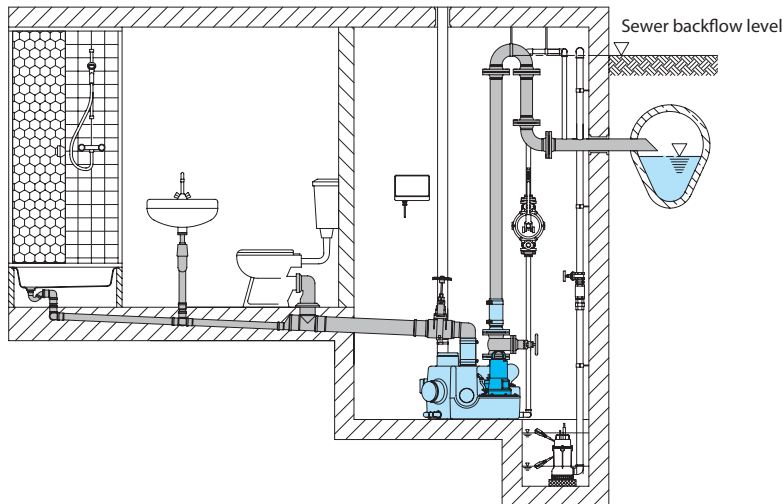

Direct connection
Euro-WC
(Inlet height 180 mm)

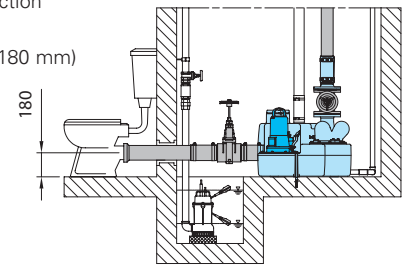

Direct connection
Hanging-WC
(Inlet height 250 mm)

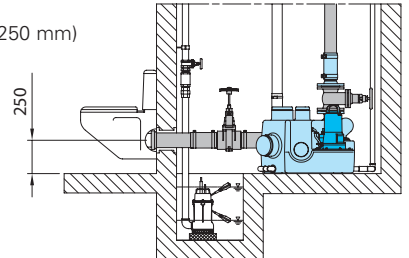

Accessories

Description	Size	Part no.	
① PVC-inlet valve	DN 100	2214110	
	DN 150	2214160	
② Elastic union piece with hose bands	DN 100	im Liefer- umfang	
	DN 150	2159542	
○ Hose clamp	S 115/20	2311520	
	GBS 168/30	2317520	
③ Flanged gate valve with 2 flanges PN 10	DN 80	2216080	
○ Set of screws with seal	galvanized	DN 80	2214080
	stainless steel	DN 80	2214082
④ Elastic union-piece with flange DN 80 for pressure pipe	DN 100	in scope of supply	
	DN 80	2159021	
○ Diaphragm pump	BSP 1" F	8502445	
○ Battery 9 V for mains-independent alarm		1952214	
○ ServCom diagnostic device for monitoring of operation data and adjustment of the control levels in the tank		1964450	

Vertical inlet

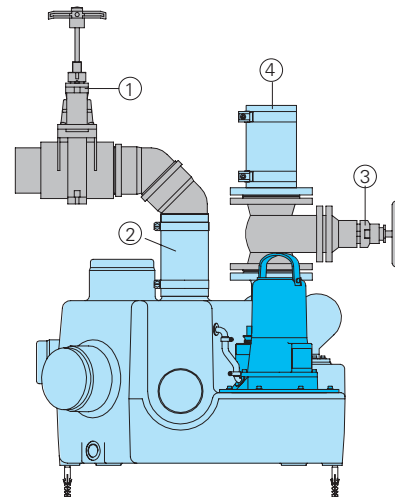

Horizontal inlet

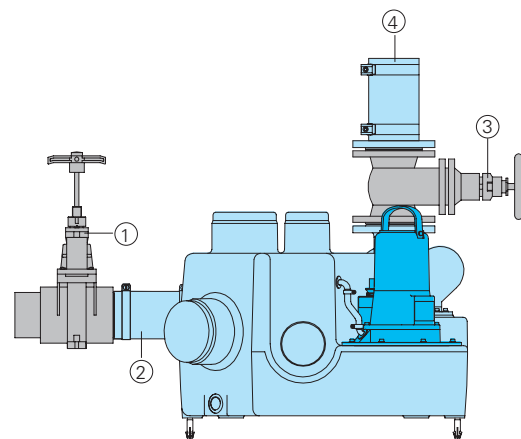

We reserve the right to alter our specifications without notice!