

**Submersible motor pumps
 with cooling jacket
 for clear and drainage water.**

Chromatic C250, C260

Application

Pump for conveying clean or soiled water. Cellar draining, keeping trenches, shafts and rooms dry. Drainage water disposal in cellar rooms (e.g. wash-basins, showers, washing machines). Reduction of surface water. Emergency deployment for flooding. Water extraction from watercourses or reservoirs for irrigation.

A cooling jacket with discharge connector at the top ensures sufficient motor cooling even at low water level (sip operation). Automatic ventilation with additional air vent screw. Removable strainer allows extraction of residual water down to 5 mm. Automatic purging device can be implemented.

DIN EN 12050-2: Design tested and monitored.

Installation: Stationary or mobile. Version with float switch for use as automatic water level controlled drainage pump.

Pumped medium: Clear- or drainage water containing solids up to 10 mm particle size. Max. temperature of pumped medium: 35°C, for brief periods up to 60°C.

Operating mode: Continuous operation (S1), at medium temperature 36- 60°C: Intermittent operation (S3 30%).

Design

Submersible pump, consisting of:

Pump: Single-stage centrifugal pump with vertical discharge and integrated non-return valve.

Impeller: Open multi-blade impeller, free passage 10 mm.

Motor: Pressure watertight, medium-immersed motor. Stainless steel motor housing. Insulation class B, Protection rating IPX8. Thermal sensor for temperature monitoring in the winding.

Connecting cable: H07RN8-F 3G1.

Shaft/bearing: strongly dimensioned chrome steel motor shaft, lifetime-lubricated roller bearings.

Seal: Shaft seal with triple radial shaft seal and ceramic-coated sealing surface.

Conveying capacities

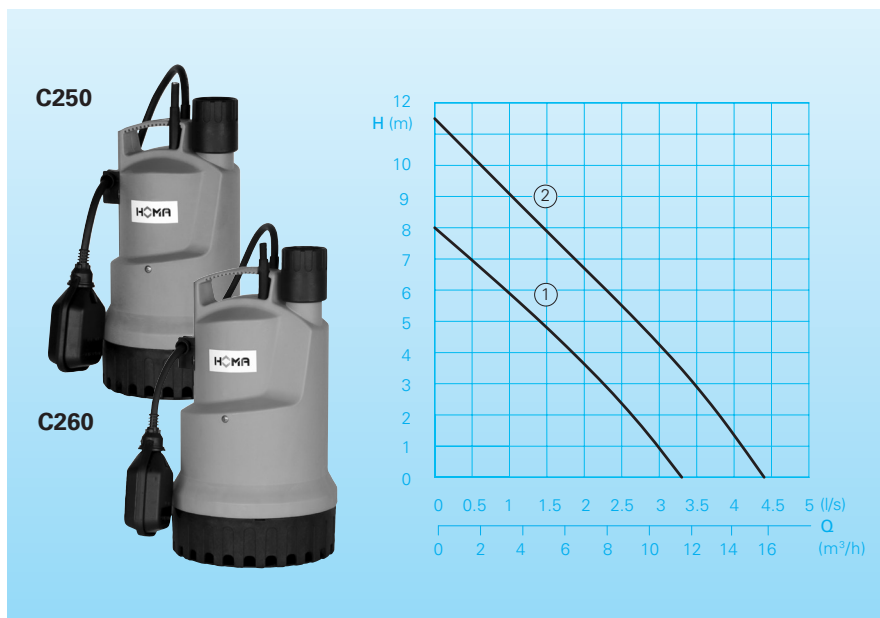

Technical data

Curve No.	Pumptype	Motor input P ₁ (kW)	P ₂ (kW)	Voltage 50 Hz (V)	Nominal current (A)	Weight (kg)
①	C250 W (A)	0,55	0,26	230/1Ph	2,5	5,3
②	C260 W (A)	0,90	0,48	230/1Ph	4,0	6,1

Rotational speed: 2850 rpm
Discharge: G1 1/4

Model A: with automatic float switch
 HOMA-Nivomatik

Materials

Motor housing, motor shaft, screws	Stainless steel
Suction sieve, outer housing, impeller, pressurized lid	impact-resistant plastic
Elastomers	NBR

Scope of supply

Pump with twin box G 1¼ inc. integrated non-return valve, washer and hose connection, 10 m of connecting cable and mains plug.

Model A: With automatic float switch HOMA-Nivomatik.

Dimensions and installation example (all dimensions in mm)

C250

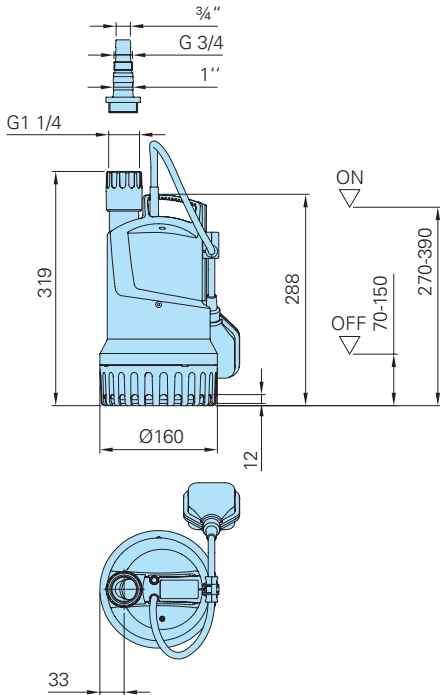

C260

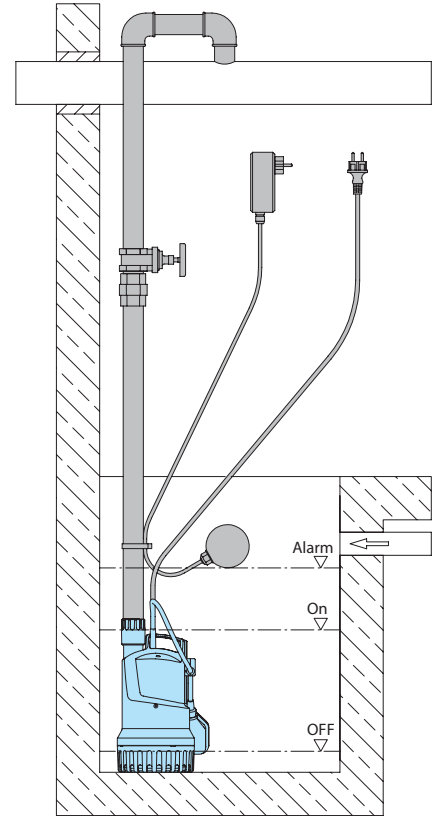
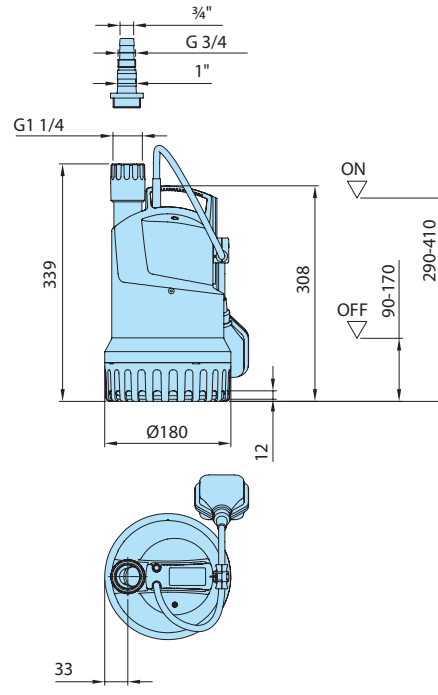

Accessories

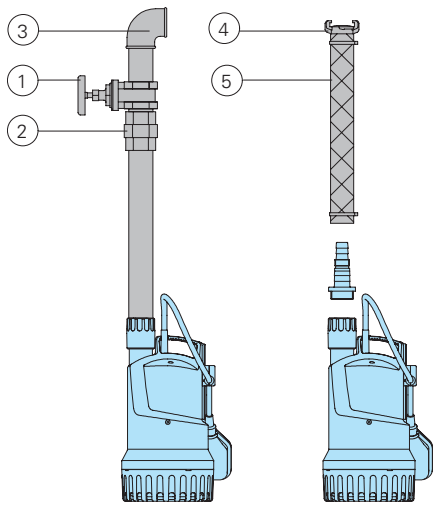

Description	Size	Part no.
① Shut-off gate valve, brass	BSP 1 1/4" F	2216012
② Transition screw connection, galvanized	BSP 1 1/4" M/F	2114304
③ Connection bend 90°, galvanized	BSP 1 1/4" F BSP 1 1/4" F/M	2113604 2111405
T-piece for merging the pressure pipe in double pump stations, galvanized	BSP 1 1/4" F	2114301
○ Non-return valve, brass (if the integrated non-return valve is omitted)	BSP 1 1/4" F	2211213
○ Double nipple, galvanized	BSP 1 1/4" M	2009011
④ Fixed coupling, Brass	BSP 1 1/4" M	2005413
Hose coupling, brass	1 1/4" 1" 3/4"	2003413 2003313 2003212
⑤ PVC-hose, per m	1 1/4" Ø 30mm 1" Ø 25 mm 3/4" Ø 19 mm	2621200 2621000 2620700
Plastic spiral hose, per m	1 1/4" Ø 32mm 1" Ø 25 mm 3/4" Ø 19 mm	2632030 2632025 2632019
Hose clamp	1 1/4" 3/4"-1"	2302330 2303252

Description	Size	Part no.
○ Fault-current circuit breaker 2-pin, Fi 16/0.03 A		1561160
○ Mains-dependent alarm control unit AL3 with connector for 9 V rechargeable battery (see below) for operation independent of mains power supply, with built-in signal transmitter, float switch and 10 m of cable. Main phase connection 230V/1Ph		1586141
9 V rechargeable battery for mains-independent alarm		1952215
○ For pump controllers and switchgears for mobile and stationary applications, measuring systems and monitoring devices, see HOMA accessories		



We reserve the right to alter our specifications without notice!