

Jacket cooled submersible drainage pump for clear water.

C 80 W

Application

The C 80 scavenger is suitable for irrigation, water transfer and drainage in clear water. For flat-water exhaust to min. 2 mm. Pumping water from collection tanks, for flood relief and water removal from water courses or reservoirs. Suitable also for water circulation in garden ponds and cascades.

The water jacket cooled motor with the top discharge protects the motor against overheating even during sip operation.

Installation: Permanent or transportable.

Pumped liquid: Clear water containing soft solids with a diameter of max. 1 mm. Max. liquid temperature: 35°C, short term up to 60°C.

Operation: Permanent (S1).

Design

Fully submersible pump consisting of:

Pump: Single stage centrifugal pump with vertical discharge BSP 3/4" M.

Impeller: Open multi-channel impeller, spherical clearance 1 mm.

Motor: Canned wet-rotor, seal-less, rotor shaft lubricated by pumped liquid. Insulation class B. Motor protection IP 68.

Shaft/Bearing: stainless steel-ceramic shaft, slide bearing.

Cable: H05RN-F3G0,75

Performance

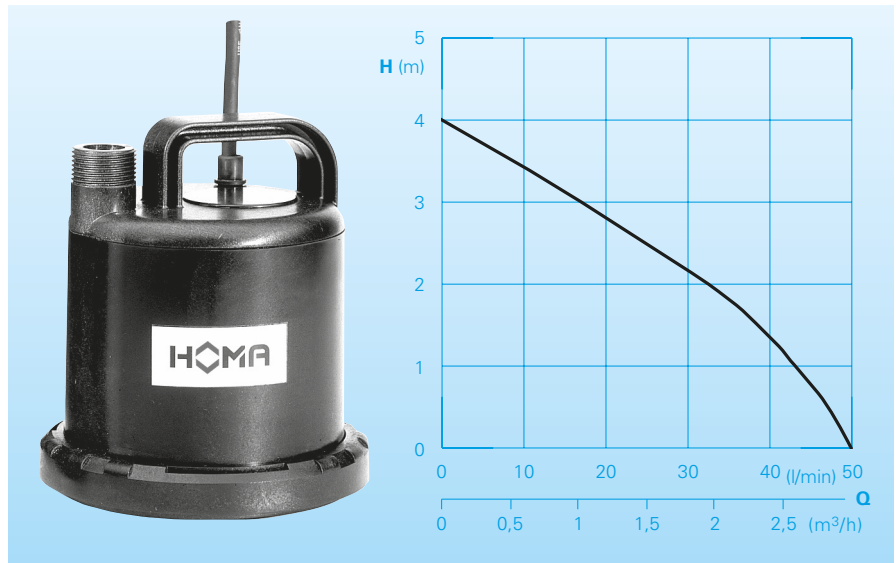

Technical Data

Pump type	Motor		Voltage 50 Hz (V)	Nominal current (A)	Cable length (m)	Weight (kg)
	P ₁ (kW)	P ₂ (kW)				
C80 W	0,09	0,05	230/1Ph	0,8	10 m	2,5

Speed: 2900 rpm

Discharge: BSP ¾ M

Materials

Motor housing motor shaft, screws	stainless steel
Suction sieve pump housing	Wear resistant synthetic material (composite)
Impeller	Glass-fibre, rein- forced synthetic (composite)
Elastomere	NBR

Equipment supplied

Pump with 10 m of cable and plug.

Dimensions (all dimensions in mm)

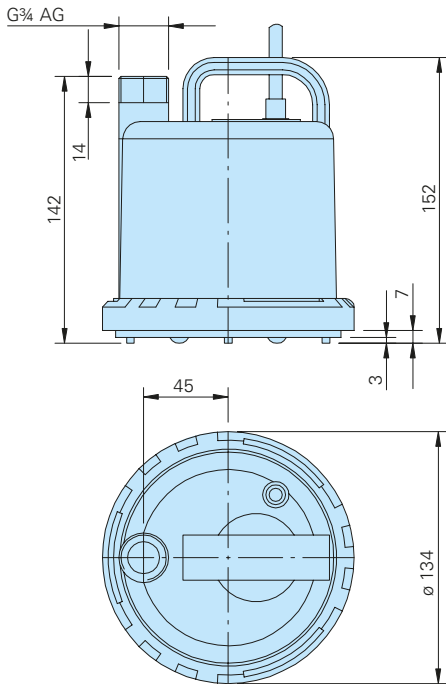

Accessories

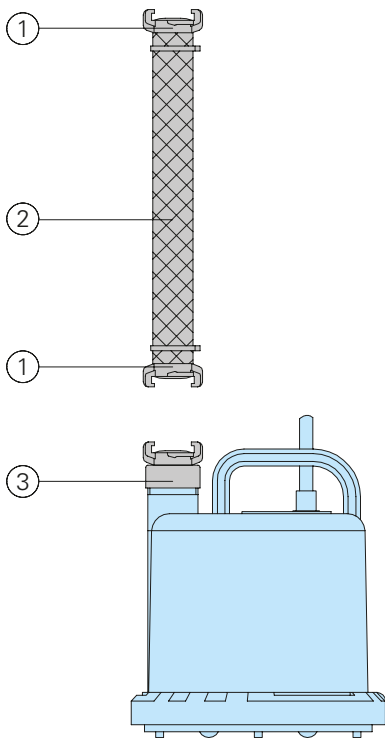

Part Description	Dimension	Part. No.	Part Description	Dimension	Part. No.
① Brass hose coupling	1"	2003313	○ HOMA-Nivomatik float switch level control, conversion unit		
② PVC hose, per m	1" Ø 25 mm	2621000	- AZW 10/5	5 m of cable	1435055
Reinforced hose, per m	1" Ø 25 mm	2632025	- AZW 10/10	10 m of cable	1430105
Hose band	3/4" - 1"	2302330	○ HOMA 2 poles earth leakage circuit breaker		
③ Brass fixed coupling	BSP 3/4" F	2005322	Fi 16/0,03 A		1561160
			○ Alarm device AL 3		
			Mains operated with connector for battery 9V (see below) for mains independent operation with integrated buzzer.		
			Mains connection		1586140
			230-240 V/ 1 Ph		
			Battery for mains-independent operation	9 V	1952215
			Float switch MB, mercury free, on or off, with integrated counter weight.		
			Cable length	6 m	1465706
				10 m	1465710



HOMA Pumpenfabrik GmbH
 P.O.Box 22 63, D-53814 Neunk.-Seelscheid
 Tel. +49 (0) 22 47/702-0, Fax +49 (0) 22 47/702-44
 e-mail: info@homa-pumpen.de
 www.homapumps.com