

Standardised Chemical Pump

MegaCPK



Type Series Booklet



Legal information/Copyright

Type Series Booklet MegaCPK

All rights reserved. The contents provided herein must neither be distributed, copied, reproduced, edited or processed for any other purpose, nor otherwise transmitted, published or made available to a third party without the manufacturer's express written consent.

Subject to technical modification without prior notice.

© KSB SE & Co. KGaA, Frankenthal 13/02/2020

Contents

Centrifugal Pumps with Shaft Seal..... 4

Standardised Chemical Pumps..... 4

 MegaCPK 4

 Main applications..... 4

 Operating data..... 4

 Design details 4

 Designation 6

 Bearing life 8

 Materials..... 9

 Coating and preservation 10

 Product benefits..... 10

 Acceptance tests and warranty 11

 Pressure limits and temperature limits 11

 Technical data 12

 Selection charts 14

 Dimensions and connections 20

 Flange design 26

 Scope of supply 26

 General assembly drawing with list of components..... 27

Centrifugal Pumps with Shaft Seal

Standardised Chemical Pumps

MegaCPK

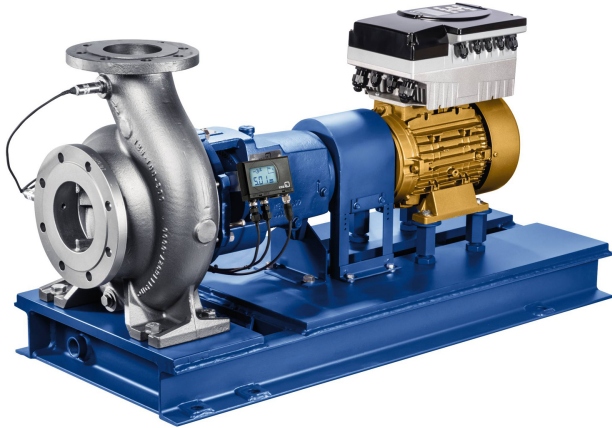

The product illustrated as an example may include options incurring a surcharge.

Main applications

- Alcohol industry
- Chemical industry (aggressive / other liquids)
- Fossil-fuelled power stations
- Food industry / beverage industry
- Seawater desalination/reverse osmosis
- Paper industry / pulp industry
- Petrochemical industry (aggressive / other liquids)
- Refinery
- Sugar industry

Operating data

Operating properties

Characteristic		Value	
		50 Hz	60 Hz
Flow rate	Q [m ³ /h]	≤ 1160	≤ 1400
Head	H [m]	≤ 162	≤ 233
Fluid temperature	T _{min.} [°C]	≥ -40	
	T _{max.} [°C]	≤ +400	
Operating pressure	p [bar]	≤ 25	

Design details

Design

- Volute casing pump
- Horizontal installation
- Back pull-out design
- Single-stage
- Technical requirements to ISO 5199
- Dimensions and ratings to ISO 2858 complemented by pumps of nominal sizes DN 25, DN 200 and above

Pump casing

- Single or double volute, depending on the pump size
- Radially split volute casing
- Volute casing with integrally cast pump feet
- Replaceable casing wear rings (optional for pump casing material C)

Shaft seal

- Gland packing
- Single mechanical seal / double mechanical seal
- Cartridge mechanical seal
- Shaft equipped with replaceable shaft protecting sleeve in the shaft seal area

Alternative:

- Version without shaft protecting sleeve with "wet shaft" (in Europe and Northern Asia only)

Alternative:

- Version without shaft protecting sleeve with "wet shaft" (in Europe and Northern Asia only)

Impeller type

- Closed radial impeller with multiply curved vanes

Bearings:

- Medium Duty
 - Radial bearing: cylindrical roller bearing
 - Fixed bearing: paired angular contact ball bearings / double-row angular contact ball bearing
- Economy bearing assembly
 - Floating bearings: deep groove ball bearings

Lubrication:

- Oil lubrication
- Grease lubrication

Bearing bracket designation

Example: CS50E

Bearing bracket designation

Code	Description
CS	Bearing bracket
50	Size code (based on dimensions of seal chamber and shaft end)
E	Bearing design

Code	Description
E	= Economy
- ¹⁾	= Medium-duty

Bearing assemblies used

Standard bearing assembly

Design	Bearing bracket	Rolling element bearings	
		Pump end	Drive end
Medium-duty (oil and grease lubrication)	CS40	NU208-E	3208
	CS50	NU310-E	2 x 7310 ²⁾
	CS60	NU312-E	2 x 7312 ²⁾
	CS80	NU216-E	2 x 7216 ²⁾
Economy (oil lubrication)	CS40E	6208 C3	6208 C3
	CS50E	6310 C3	6310 C3
	CS60E	6312 C3	6312 C3
	CS80E	6216 C3	6216 C3
Economy (grease lubrication)	CS40E	6208-2Z C3	6208-2Z C3
	CS50E	6310-2Z C3	6310-2Z C3
	CS60E	6312-2Z C3	6312-2Z C3
	CS80E	6216-2Z C3	6216-2Z C3

Automation

Automation options:

- PumpDrive
- PumpMeter
- KSB Guard

1) Blank
2) FAG designation: B-TVP-UA; SKF designation: BECBP

Designation

Designation example

Position																																			
1	2	3	4	5	6	7	8	9	10	11	12	13	14	15	16	17	18	19	20	21	22	23	24	25	26	27	28	29	30	31	32	33	34	35	36
M	C	P	K	0	5	0	-	0	3	2	-	1	2	5	1	C	D	H	I	X	N	C	E	D	1	3	2	0	6	A	P	D	2	E	M
See name plate and data sheet																	See data sheet																		

Designation key

Position	Code	Description
1-4	Pump type	
	MCPK	MegaCPK
5-16	Size	
	200	Nominal suction nozzle diameter [mm]
	150	Nominal discharge nozzle diameter [mm]
	4001	Nominal impeller diameter [mm]
17	Pump casing material	
	C	Stainless steel 1.4408 / A743CF8M
	D	NORIDUR 1.4593 / 1.4517 / A995 Gr. 1B
	E	Unalloyed steel GP240GH + N / A216 Gr. WCB
	F	Stainless steel 1.4308 / A743 Gr. CF8
	G	Cast iron EN-GJL-250 / A48 Cl. 35B
	O	Super duplex stainless steel Noriclor / 1.4573 / 1.4469.09 / ASTM 995 Gr. 5A
	S	Nodular cast iron JS1030 / A536 60-40-18
18	Impeller material	
	C	Stainless steel 1.4408 / A743CF8M
	D	NORIDUR 1.4593 / 1.4517 / A995 Gr. 1B
	E	Unalloyed steel GP240GH+N / A216 Gr. WCB
	F	Stainless steel 1.4308 / A743 Gr. CF8
	G	Cast iron EN-GJL-250 / A48 Cl. 35B
	O	Super duplex stainless steel Noriclor / 1.4573 / 1.4469.09 / ASTM 995 Gr. 5A
	S	Nodular cast iron JS 1030 / A536 60-40-18
19	Heatable version and/or orifice plate	
	³⁾	Standard
	D	Orifice plate
	H	Heatable casing and heatable casing cover (welded heating chamber)
	K	Heatable or coolable casing cover (bolted heating chamber / cooling chamber)
	M	Heatable casing and heatable casing cover (bolted heating chamber)
	N	Orifice plate and heatable casing and heatable casing cover (bolted heating chamber / cooling chamber)
	P	Orifice plate and heatable or coolable casing cover (bolted heating chamber / cooling chamber)
Z	Orifice plate and heatable casing and heatable casing cover (welded heating chamber)	
20	Hydraulic system	
	³⁾	Standard
	E	Extended-flow hydraulic system
	I	With auxiliary impeller
	L	Standard-flow hydraulic system
21	Design	
	³⁾	Standard
	X	Non-standard (BT3D, BT3)
22	Bearing bracket	

3) Blank

Position	Code	Description
22	C	Normal, coolable (medium-duty bearing assembly)
	F	Fire-fighting system
	M	Normal (medium-duty bearing assembly)
	N	Normal (economy bearing assembly)
23-25	Seal options	
	A	A-type casing cover (conical casing cover)
	AD	A-type casing cover with throttling bush as quench seal
	AQ	A-type casing cover with lip seal as quench seal
	B	Dead-end
	BD	Dead-end, with throttling bush as quench seal
	BQ	Dead-end, with lip seal as quench seal
	CA	Cartridge mechanical seal (A-type casing cover)
	CB	Double cartridge mechanical seal, supplied with barrier fluid pressure
	CBA	Double cartridge mechanical seal, supplied with barrier fluid pressure (A-type casing cover)
	CDA	Cartridge mechanical seal with throttling bush as quench seal (A-type casing cover)
	CE	Cartridge mechanical seal with external circulation
	CED	Cartridge mechanical seal with external circulation and throttling bush as quench seal
	CEQ	Cartridge mechanical seal with external circulation and lip seal as quench seal
	CI	Cartridge mechanical seal with internal circulation
	CID	Cartridge mechanical seal with internal circulation and throttling bush as quench seal
	CIQ	Cartridge mechanical seal with internal circulation and lip seal as quench seal
	CQA	Cartridge mechanical seal with lip seal as quench seal (A-type casing cover)
	CT	Double cartridge mechanical seal, with unpressurised quench fluid
	CTA	Double cartridge mechanical seal, with unpressurised quench fluid (A-type casing cover)
	DB	Double mechanical seal in back-to-back arrangement
	DR	Double mechanical seal in back-to-back arrangement with pumping screw
	E	External circulation
	EB	Internal circulation with heatable seal cover and throttling bush as quench seal
	ED	External circulation with throttling bush as quench seal
	EQ	External circulation with lip seal as quench seal
	ES	Internal circulation with heatable seal cover
	F	External flushing
	FD	External flushing with throttling bush as quench seal
	FQ	External flushing with lip seal as quench seal
	I	Internal circulation
	ID	Internal circulation with throttling bush as quench seal
	IDH	Internal circulation with heatable casing cover and throttling bush as quench seal
	IH	Internal circulation with heatable casing cover
	IQ	Internal circulation with lip seal as quench seal
	IQH	Internal circulation with heatable casing cover and lip seal as quench seal
	P1	Gland packing variant with internal barrier fluid (Na)
	P2	Gland packing variant without barrier fluid (Nb)
	P3	Gland packing variant with external barrier fluid (Nc)
	TM	Mechanical seals in tandem arrangement, with barrier fluid and jacket cooling
	TR	Mechanical seals in tandem arrangement, outboard seal with pumping screw
TS	Mechanical seals in tandem arrangement, supplied with barrier fluid pressure	
26-29	Motor rating P _N [kW]	
	0007	0,75

	1320	132
30	Number of motor poles	

Position	Code	Description
31	Product generation	
	A	MegaCPK from 2012
32-35	PumpDrive	
	PDA	With PumpDrive 1st generation, Advanced
	PDB	With PumpDrive 1st generation, Basic
	PDS	With PumpDrive 1st generation, Advanced, with KSB SuPremE motor
	PD2	With PumpDrive 2nd generation
	PD2E	With PumpDrive 2nd generation, Eco
36	PumpMeter	
	M	With PumpMeter

Bearing life

The calculated minimum bearing life is:

- 17,500 h for economy bearing assemblies
- 25,000 h for medium-duty bearing assemblies or 40,000 h for operation between $0.7-1.1Q/Q_{opt}$

Materials

Overview of available materials (Europe)

Description	Material variant											
	GG ⁴⁾	GC ⁴⁾	GD ⁴⁾	EG	EC	ED	CC	CD	VC	VD	DD	OO
Volute casing	CI			CS			SS		1.4408 ⁵⁾		D	SD
Casing cover	CI			CS			SS		1.4408 ⁵⁾		D	SD
Impeller	CI	SS	D	CI	SS	D	SS	D	SS	D	D	SD
Shaft	C45+N ⁶⁾											C45+N ⁷⁾
Bearing bracket	DI											
Support foot	Steel											
Seal cover	CrNiMoSt										DS	SDS
Casing wear ring	CI ⁸⁾			_8 ⁹⁾			_10)		_10)		_11)	12)
Impeller wear ring	-			_13)	-	_11)	_10)	_11)	_10)	_11)	_11)	12)
Shaft protecting sleeve (mechanical seal)	CrNiMoSt										DS	SDS
Shaft protecting sleeve (gland packing)	1.4122			1.4122			CrNiMoSt		CrNiMoSt		DS	SDS
Impeller nut	CrNiMoSt										D	SDS

Overview of available materials (Northern Asia)

Description	Material variant									
	GG ⁴⁾	GC ⁴⁾	GD ⁴⁾	EG	EC	ED	CC	CD	DD	
Volute casing	CI			CS			SS		D	
Casing cover	CI			CS			SS		D	
Impeller	CI	SS	D	CI	SS	D	SS	D	D	
Shaft	C45+N ⁶⁾									
Bearing bracket	DI									
Support foot	Steel									
Seal cover	CrNiMoSt									DS
Casing wear ring	CI ⁸⁾			_8 ⁹⁾			_10)		-	
Impeller wear ring	-			_13)	-	_11)	_10)	_11)	_11)	
Shaft protecting sleeve (mechanical seal)	CrNiMoSt									DS
Shaft protecting sleeve (gland packing)	1.4122			1.4122			CrNiMoSt		DS	
Impeller nut	CrNiMoSt									D

4) Sizes 065-040-160.1, 065-040-200.1, 065-040-250.1, 080-050-160.1, 080-050-200.1, 080-050-250.1, 080-050-315.1 and 125-080-200.1 are not available in material variant G.

5) To VDMA 24276

6) T ≤ 10 °C: 1.4462, T > 250 °C: 1.7709. QT+SR, wet shaft: 1.4462

7) T ≤ 10 °C: 1.4462, T > 250 °C: 1.7709. QT+SR, wet shaft: 1.4501

8) Optional: VG434

9) Optional: CI

10) Optional: CrNiMo ST Int

11) Optional: DS

12) Optional: SD

13) Optional: 1.4027+QT

Overview of available materials (Southern Asia)

Description	Material variant							
	GG	GB	GC	EE	EC	FF	CC	DD
Volute casing	CI	CI	CI	CS	CS	SS304	SS	D
Casing cover	CI	CI	CI	CS	CS	SS304	SS	D
Impeller	CI	B	SS	CS	SS	SS304	SS	D
Shaft	IS 5517 45C8		IS 5517 45C8 ¹⁴⁾		IS 5517 45C8 ¹⁵⁾			IS 5517 45C8
Bearing bracket	CI							
Support foot	St (S235JR)							
Seal cover	CrNiMoSt					CrNiSt	CrNiMoSt	DS
Casing wear ring	CI	IS318 Gr. L TB4	A743 Gr. CF8M	_16)	_17)	-	_17)	-
Impeller wear ring	-	-	-	_16)	_17)	-	_17)	_11)
Shaft protecting sleeve (mechanical seal)	A276 TYPE 316					CrNiSt	A276 TYPE 316	DS
Shaft protecting sleeve (gland packing)	A276 TYPE 316	A276 TYPE 410 COND. H			A276 TYPE 316	CrNiSt	A276 TYPE 316	DS
Impeller nut	A743 Gr. CF8M					CrNiSt	A743 Gr. CF8M	D

Overview of available materials (Americas)

Description	Material variant									
	GG	GC	CC	CX	EE	EC	BB	SS	SC	DD
Volute casing	CI		SS		CS		B	DI		D
Casing cover	CI		SS		CS		B	DI		D
Impeller	CI	SS	SS	CR	CS	SS	B	DI	SS	D
Shaft	A576 Gr. 1045 ¹⁸⁾									DS
Bearing bracket	CI									
Support foot	Steel									
Seal cover	CrNiMoSt									DS
Casing wear ring	CI		_19)	_20)		B ¹⁹⁾	CI		_11)	
Shaft protecting sleeve (mechanical seal)	CrNiMoSt									DS
Shaft protecting sleeve (gland packing)	CI	CrNiMoSt								DS
Impeller nut	CrNiMoSt									D

Codes used

Code	Material
B	IS318 Gr. LTB2 or CC480K-GS
CrNiSt	1.4308/ A743 Gr. CF-8
CrNiMoSt	1.4408/ 1.4404/ 1.4401/ 1.4571/ A743 Gr. CF-8M/ A276 TYPE 316/ A479 Gr. 316L
CI	EN-GJL-250/A48 Cl. 35B
CR	A743 CA6NM
CS	GP240GH+N/ A216 Gr. WCB
D	1.4593/ 1.4517/ A995 Gr. 1B
DI	EN-GJS-400-18-LT
DS	1.4462/ UNS S31803
SS	1.4408/ A743 Gr. CF8M
SS304	1.4308/A743 Gr. CF8
SD	Noriclor/ 1.4573/1.4469.09/ASTM 995 Gr. 5A / 1.4501

Coating and preservation

- Coating and preservation to KSB standard

Product benefits

- Hydraulic characteristics optimised for excellent efficiency and NPSH, ensuring energy-efficient and environmentally friendly use of resources
- Lower investment costs as duty points required can be achieved with smaller pump sizes
- Lower operating costs due to reduced energy consumption, optimised spare parts concept and hard-wearing, service-friendly design
- Flexible use due to modular design regarding hydraulic system materials, sealing elements, bearing brackets, coupling, baseplate and drive

- 14) Optional: A276 TYPE 410 COND. H
15) Optional: A276 TYPE 410 COND. H, A276 TYPE 316, 1.4462
16) Optional: casing wear ring in Chrome hard 400 in combination with impeller wear ring A743 Gr. CA15.09
17) Optional: casing wear ring A743 Gr. CF8M in combination with impeller wear ring A743 Gr. CF8M
18) Optional: 1.4021/ A276 TYPE 20 or A276 TYPE 316
19) Optional: SS
20) Optional: 1.4021/ AISI420

Acceptance tests and warranty

- Materials testing
 - Test report 2.2 on request
- Final inspection
 - Inspection certificate 3.1 to EN 10204 on request
- Hydraulic test

The operating point of each pump is guaranteed to ISO 9906/3B.

The following acceptance tests can be performed and certified at extra charge:

- Performance test to ISO 9906
- NPSH test
- Other inspections/tests on request
- Warranty

Warranties are given within the scope of the valid terms and conditions of sale and delivery.

Pressure limits and temperature limits

Pressure limits and temperature limits of the pump

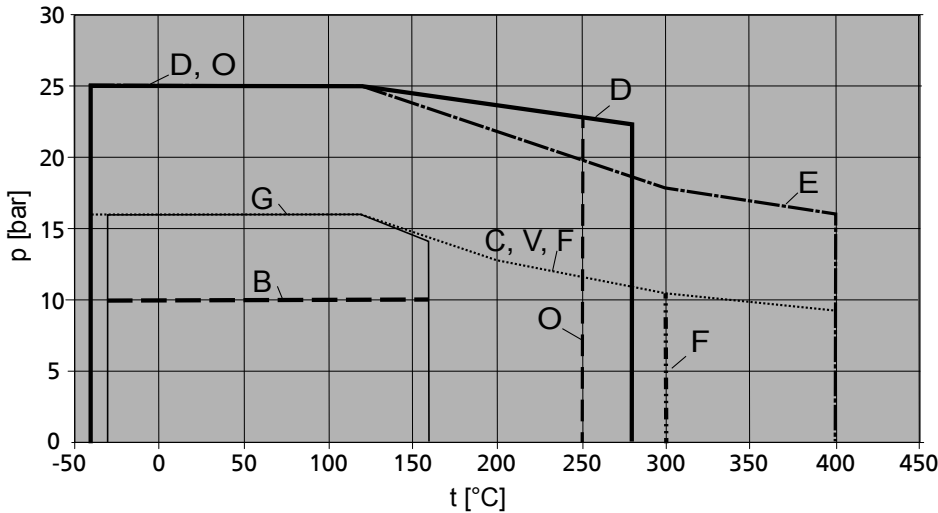

Fig. 1: Pressure limits and temperature limits of the pump

Pressure limits and temperature limits for heating chamber (heatable version)

Pressure limits and temperature limits for heating chamber, heatable version

Design	Maximum temperature [°C]	Maximum pressure [bar]
Version with welded casing cover	300	20
Version with bolted casing cover	150	10

Pressure limits and temperature limits of shaft seals

The application limits of shaft seals depend on the circumferential speed, the material and the fluid handled. Verify the application limits in each individual case on the basis of manufacturers' catalogues, taking into account the actual operating conditions.

Pressure limits and temperature limits of ASME flanges

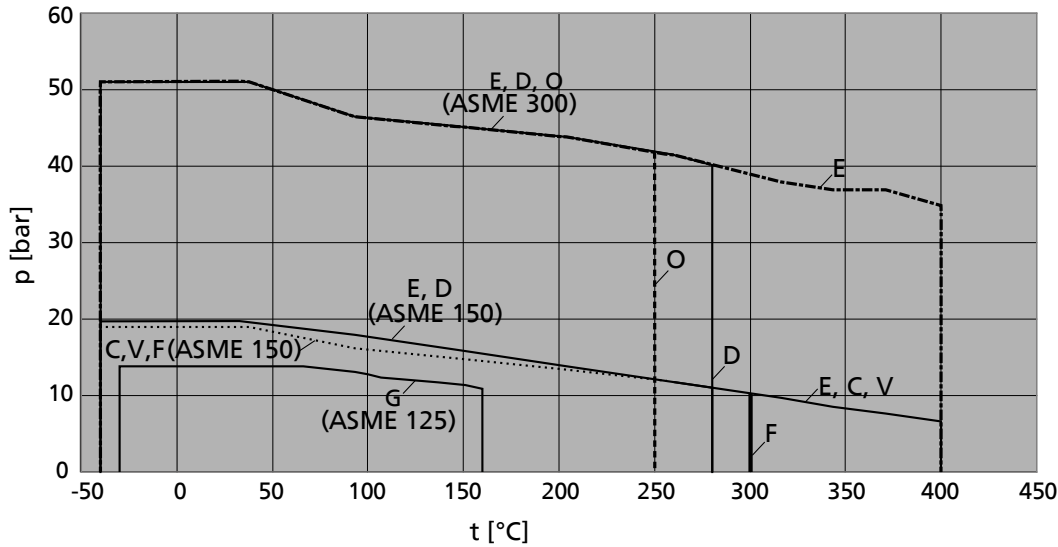

Fig. 2: Pressure limits and temperature limits of ASME flanges

On models with ASME flanges, the pressure limits and temperature limits are determined by the lowest value given in the "Pressure limits and temperature limits of the pump" diagram and the "Pressure and temperature limits of ASME flanges" diagram.

Pressure limits and temperature limits of flanges drilled to ASME 125 see diagram "Pressure limits and temperature limits of the pump", material variant G.

Technical data

Technical data

Size	Bearing bracket	Impeller					Shaft diameter in seal chamber			Diameter of shaft protecting sleeve			Volute casing design ²¹⁾	Hydraulic system design ²²⁾	Heatable casing			
		Impeller outlet width	Free passage	Impeller inlet diameter	Impeller diameter		Number of vanes	Dry shaft	Wet shaft		Bearing	Coupling				Gland packing	Mechanical seal	
					Max.	Min.			Northern Asia / Europe	Americas							Northern Asia / Europe / Southern Asia	Americas
[mm]	[mm]	[mm]	[mm]	[mm]	[mm]	[mm]	[mm]	[mm]	[mm]	[mm]	[mm]	[mm]	[mm]	[mm]				
040-025-160	CS40	6	5,7	44	169	130	4	28	33	35	40	24	35	33	35	E	L	X
040-025-200	CS40	6	5,7	44	209	160	4	28	33	35	40	24	35	33	35	E	L	X
050-032-125	CS40	10	5,7	63	139	110	6	28	33	35	40	24	35	33	35	E	E	X
050-032-125.1	CS40	7	6,0	52	139	114	6	28	33	35	40	24	35	33	35	E	E	-
050-032-160	CS40	9	5,8	63	174	135	6	28	33	35	40	24	35	33	35	E	E	X
050-032-160.1	CS40	6	5,4	52	170	138	6	28	33	35	40	24	35	33	35	E	L	X
050-032-200	CS40	7	6,7	62	209	170	6	28	33	35	40	24	35	33	35	E	E	X
050-032-200.1	CS40	6	5,3	54	204	138	6	28	33	35	40	24	35	33	35	E	E	X
050-032-250	CS50	8	7,1	63	261	205	6	38	43	45	50	32	45	43	45	E	E	X
065-040-125	CS40	14	9,6	74	139	110	6	28	33	35	40	24	35	33	35	E	E	-
050-032-250.1	CS50	6	5,2	58	254	210	6	38	43	45	50	32	45	43	45	E	E	X
065-040-160	CS40	13	11,5	70	174	135	6	28	33	35	40	24	35	33	35	E	E	X
065-040-160.1	CS40	9	8,5	65	169	130	6	28	33	-	40	24	35	33	-	E	L	X
065-040-200	CS40	9	8,9	69	209	175	6	28	33	35	40	24	35	33	35	E	E	X
065-040-200.1	CS40	7	6,6	65	209	160	5	28	33	-	40	24	35	33	-	E	L	X

21) D = double volute, E = single volute

22) E = extended-flow hydraulic system, L = standard-flow hydraulic system

Size	Bearing bracket	Impeller						Shaft diameter in seal chamber			Bearing	Coupling	Diameter of shaft protecting sleeve			Volute casing design ¹⁾	Hydraulic system design ²⁾	Heatable casing
		Impeller outlet width	Free passage	Impeller inlet diameter	Impeller diameter		Number of vanes	Dry shaft	Wet shaft									
					Max.	Min.			Northern Asia / Europe	Americas								
		[mm]	[mm]	[mm]	[mm]	[mm]	[mm]	[mm]	[mm]	[mm]			[mm]	[mm]	[mm]			
065-040-250	CS50	8	8,0	73	260	200	6	38	43	45	50	32	45	43	45	E	E	X
065-040-250.1	CS50	7	6,6	68	260	200	6	38	43	-	50	32	45	43	-	E	L	X
065-040-315	CS50	8	7,1	75	326	278	6	38	43	45	50	32	45	43	45	E	E	X
080-050-125	CS40	20	11,6	88	142	114	6	28	33	35	40	24	35	33	35	E	E	-
080-050-160	CS40	17	11,6	87	174	128	6	28	33	35	40	24	35	33	35	E	E	X
080-050-160.1	CS40	15	9	82	169	130	6	28	33	-	40	24	35	33	-	E	L	X
080-050-200	CS40	14	11,9	83	219	170	6	28	33	35	40	24	35	33	35	E	E	X
080-050-200.1	CS40	12	6,7	82	209	160	5	28	33	-	40	24	35	33	-	E	L	X
080-050-250	CS50	11	10,0	84	260	220	6	38	43	45	50	32	45	43	45	E	E	X
080-050-250.1	CS50	10	7	85	260	200	6	38	43	-	50	32	45	43	-	E	L	X
080-050-315	CS50	10	9,5	86	323	260	6	38	43	45	50	32	45	43	45	E	E	X
080-050-315.1	CS50	8	7,6	85	320	260	6	38	43	-	50	32	45	43	-	E	L	X
100-065-125	CS40	26	12,9	99	141	114	6	28	33	35	40	24	35	33	35	E	L	-
100-065-160	CS50	21	12,2	92	174	132	6	38	43	45	50	32	45	43	45	E	L	-
100-065-200	CS50	17	13,3	100	219	165	6	38	43	45	50	32	45	43	45	E	L	X
100-065-250	CS50	15	14,3	101	260	220	6	38	43	45	50	32	45	43	45	E	L	X
100-065-315	CS60	14	13,0	107	320	245	6	48	53	55	60	42	55	53	55	E	E	X
125-080-160	CS50	32	15,1	124	174	138	6	38	43	45	50	32	45	43	45	E	E	-
125-080-200	CS50	25	15,2	115	219	165	6	38	43	45	50	32	45	43	45	E	L	X
125-080-200.1	CS50	22	11,9	116	209	140	7	38	43	-	50	32	45	43	-	E	L	X
125-080-250	CS50	19	15,8	115	269	220	6	38	43	45	50	32	45	43	45	E	L	X
125-080-315	CS60	19	17,8	115	334	281	6	48	53	55	60	42	55	53	55	E	L	X
125-080-400	CS60	15	14,3	129	398	265	6	48	53	55	60	42	55	53	55	E	E	X
125-100-160	CS50	38	16,4	135	185	155	6	38	43	45	50	32	45	43	45	E	L	X
125-100-200	CS50	33	17,9	142	219	170	6	38	43	45	50	32	45	43	45	E	L	-
125-100-250	CS60	27	18,8	145	262	216	6	48	53	55	60	42	55	53	55	E	L	X
125-100-315	CS60	23	19,9	142	334	250	6	48	53	55	60	42	55	53	55	E	E	X
125-100-400	CS60	18	17,1	142	401	329	6	48	53	55	60	42	55	53	55	E	E	-
150-125-200	CS60	41	21,1	160	224	162	6	48	53	55	60	42	55	53	55	E	L	-
150-125-250	CS60	37	22,4	162	269	218	6	48	53	55	60	42	55	53	55	E	E	X
150-125-315	CS60	31	22,6	162	334	280	6	48	53	55	60	42	55	53	55	E	E	X
150-125-400	CS60	26	20,9	162	419	330	6	48	53	55	60	42	55	53	55	E	E	X
200-150-200	CS60	60	25,2	179	224	158	6	48	53	55	60	42	55	53	55	E	-	-
200-150-250	CS60	49	23,0	191	269	220	6	48	53	55	60	42	55	53	55	E	L	X
200-150-315	CS80	40	26,9	192	334	264	6	60	65	65	80	48	70	65	65	E	L	X
200-150-400	CS80	33	23,8	191	419	330	6	60	65	65	80	48	70	65	65	E	L	-
200-150-500	CS80	23	19,1	190	504	400	7	60	65	65	80	48	70	65	65	D	-	-
200-200-250	CS80	62	37,2	190	260	200	5	60	65	65	80	48	70	65	65	E	-	-
250-200-315	CS80	50	20,8	222	320	260	7	60	65	65	80	48	70	65	65	E	-	X
250-200-400	CS80	40	18,4	222	404	320	8	60	65	65	80	48	70	65	65	D	-	X
250-200-500	CS80	32	20,6	222	504	400	7	60	65	65	80	48	70	65	65	D	-	X
300-250-315	CS80	73	26,7	270	324	260	6	60	65	65	80	48	70	65	65	D	-	X

Selection charts

MegaCPK, n = 2900 rpm

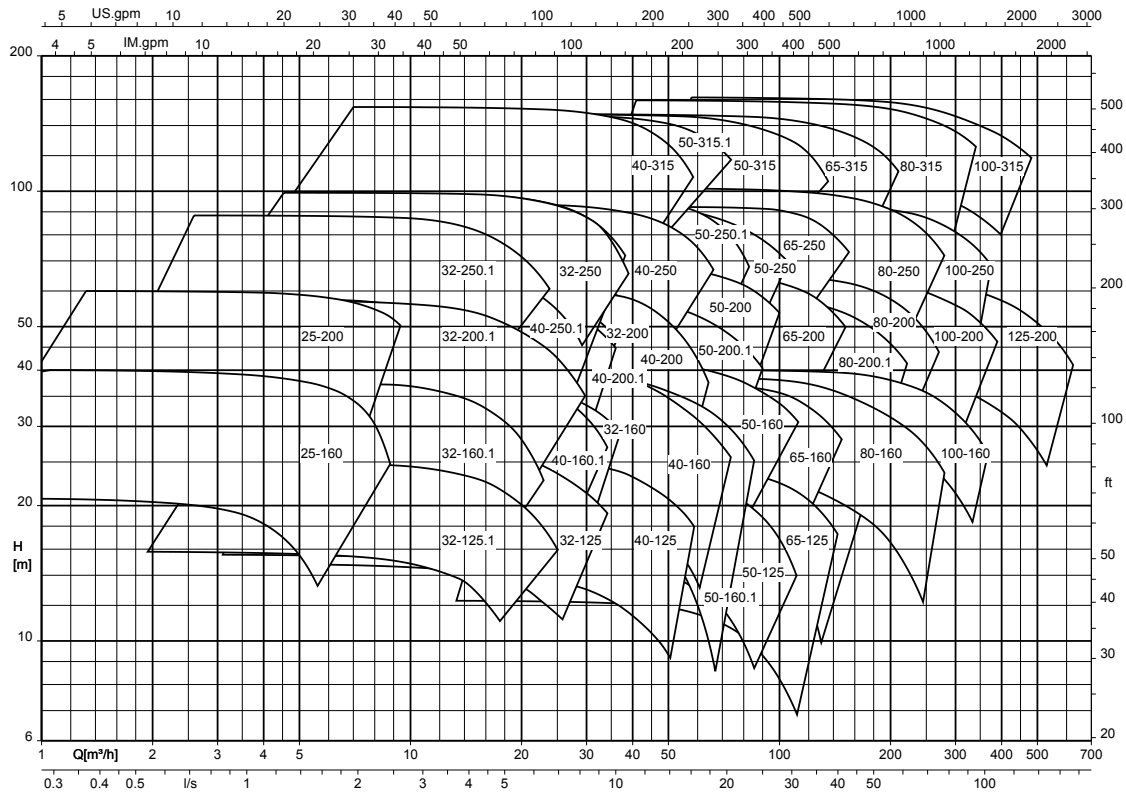

The following sizes are **only** available in the countries indicated:
 Europe and Northern Asia 040-160.1, 040-250.1, 050-315.1
 Europe 040-200.1, 050-160.1, 050-200.1, 050-250.1, 080-200.1

MegaCPK, n = 1450 rpm

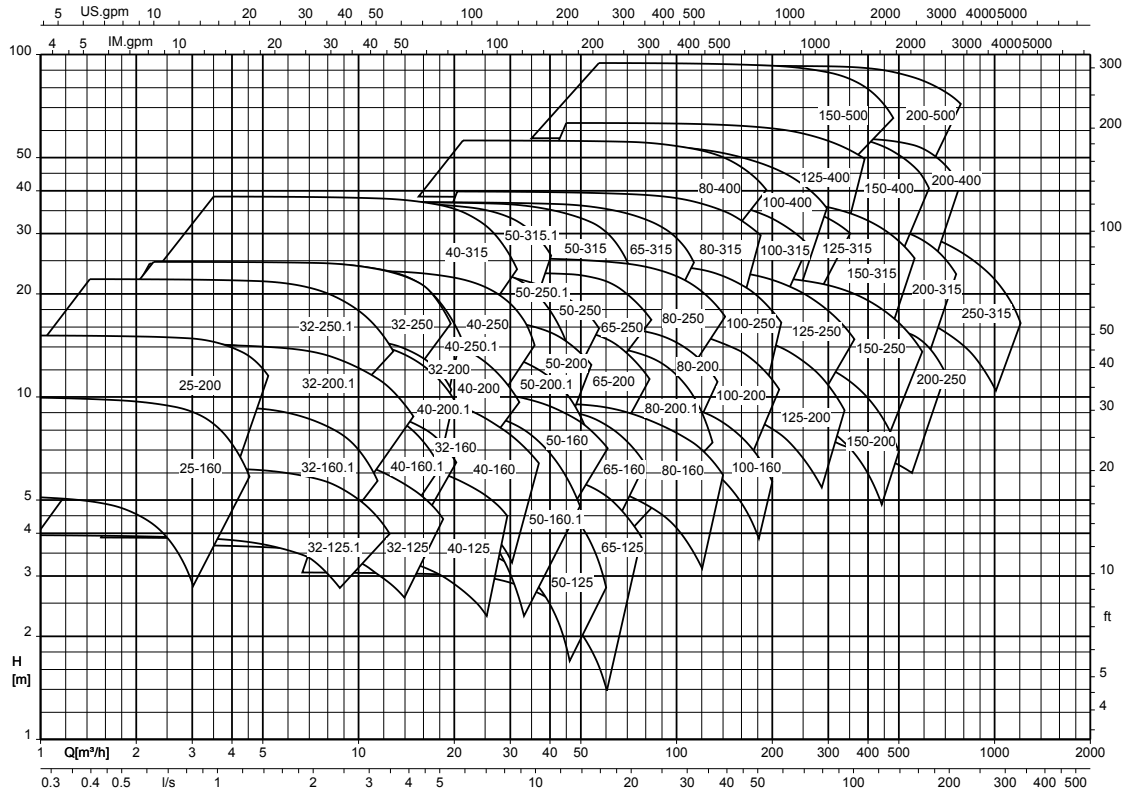

The following sizes are **only** available in the countries indicated:

Europe and Northern Asia 040-160.1, 040-250.1, 050-315.1

Europe 040-200.1, 050-160.1, 050-200.1, 050-250.1, 080-200.1

MegaCPK, n = 960 rpm

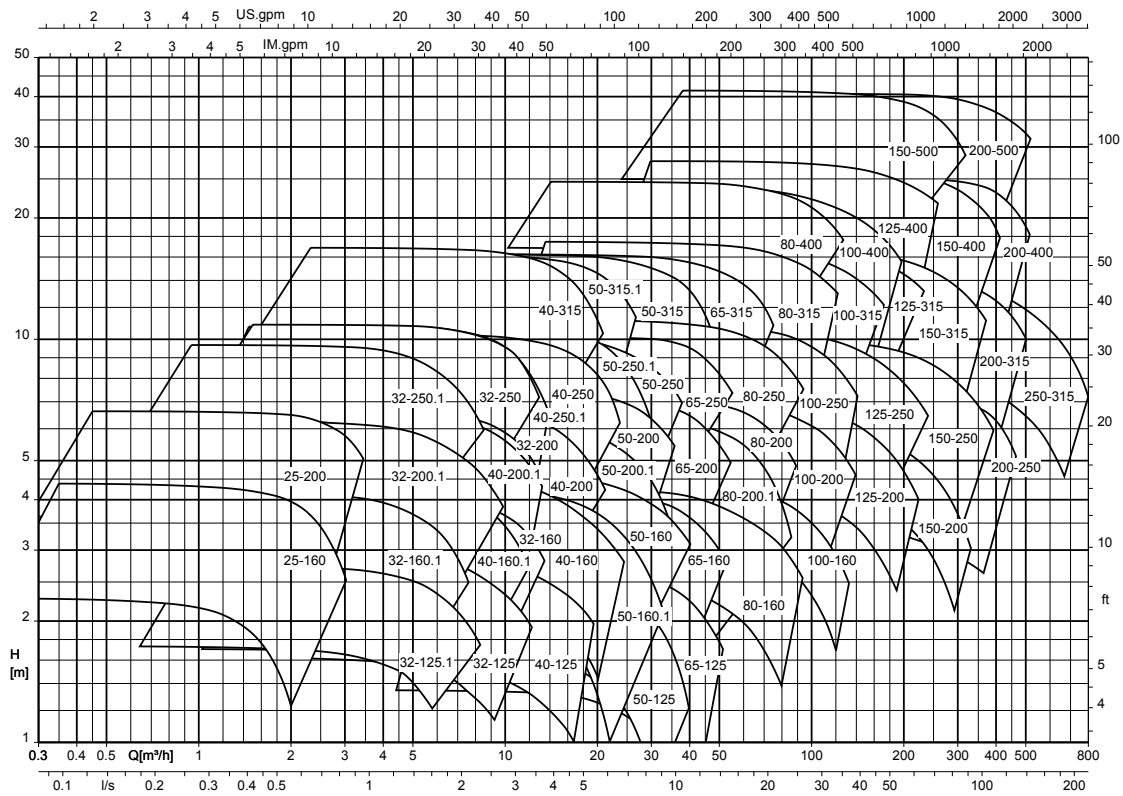

The following sizes are **only** available in the countries indicated:

Europe and Northern Asia 040-160.1, 040-250.1, 050-315.1

Europe 040-200.1, 050-160.1, 050-200.1, 050-250.1, 080-200.1

MegaCPK, n = 3500 rpm

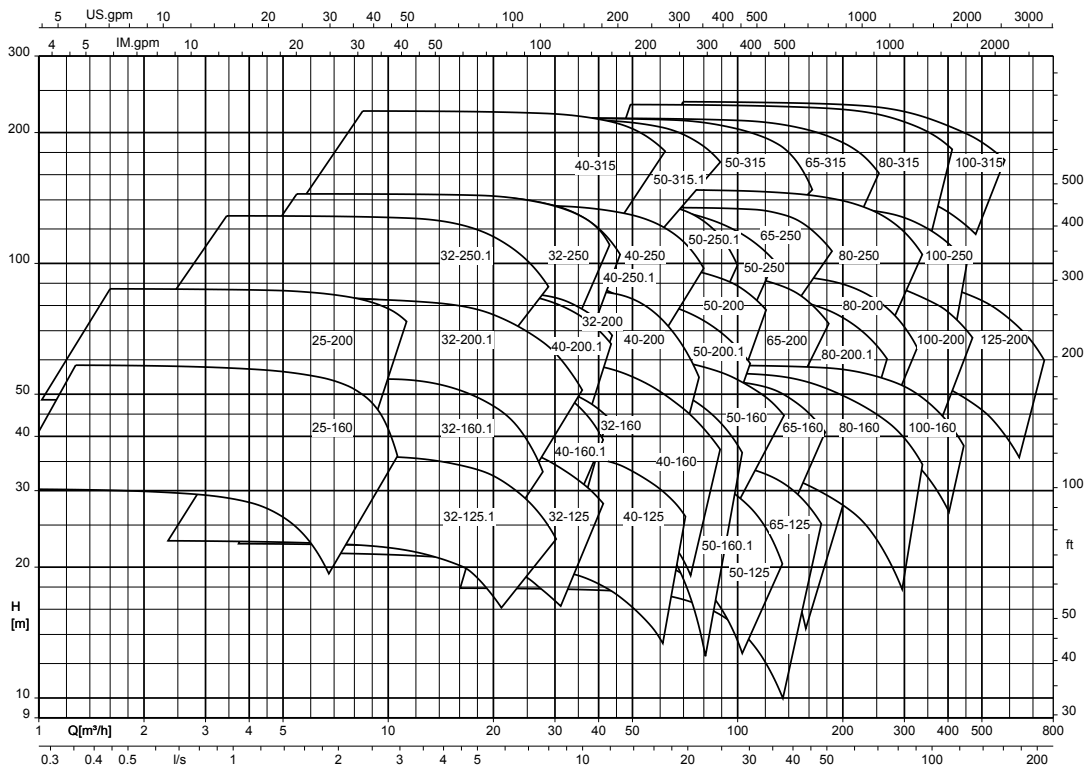

The following sizes are **only** available in the countries indicated:

Europe and Northern Asia 040-160.1, 040-250.1, 050-315.1

Europe 040-200.1, 050-160.1, 050-200.1, 050-250.1, 080-200.1

MegaCPK, n = 1750 rpm

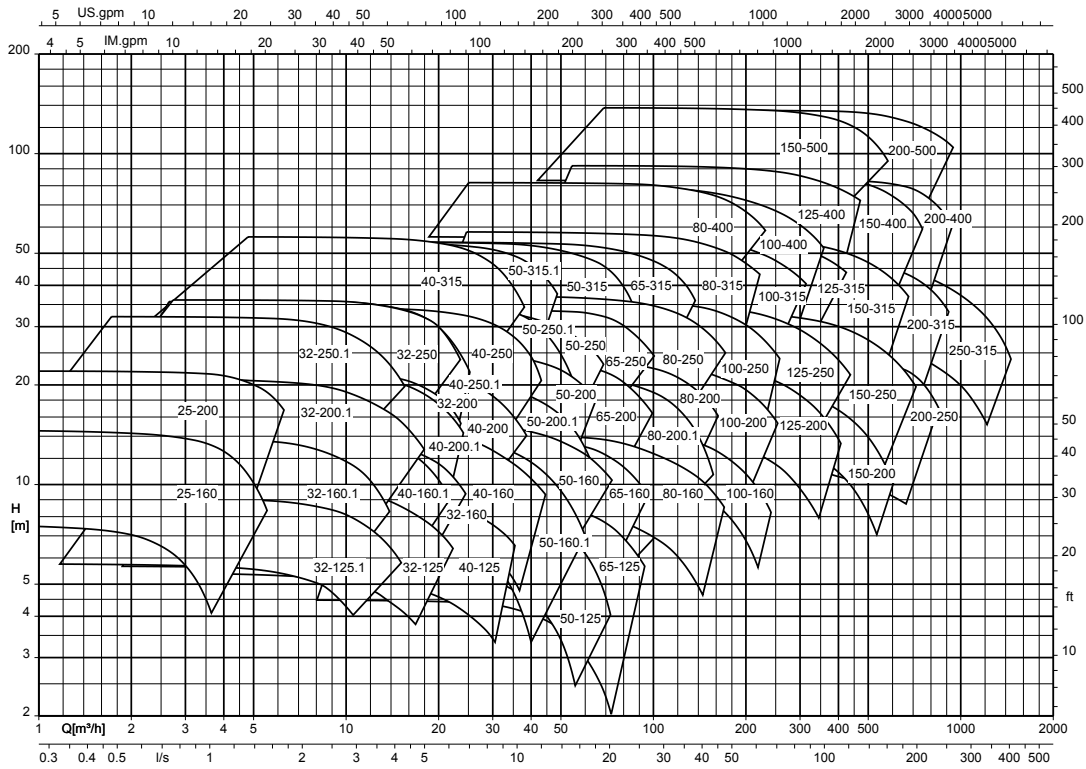

The following sizes are **only** available in the countries indicated:

Europe and Northern Asia 040-160.1, 040-250.1, 050-315.1

Europe 040-200.1, 050-160.1, 050-200.1, 050-250.1, 080-200.1

MegaCPK, n = 1160 rpm

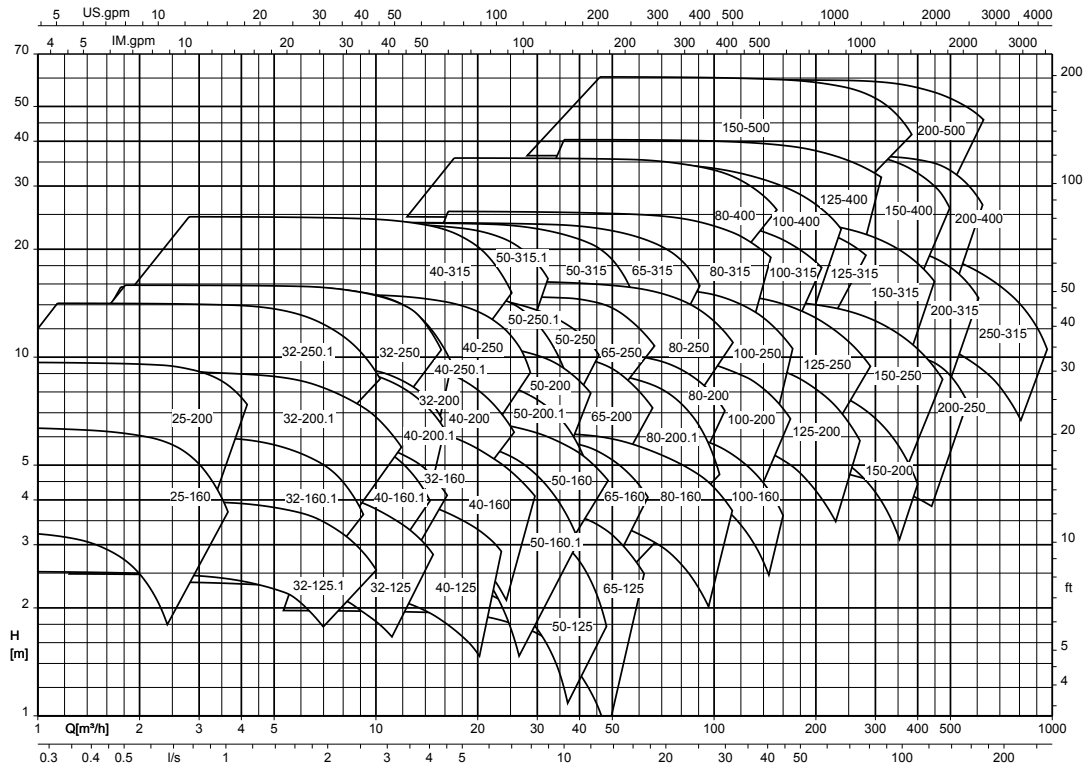

The following sizes are **only** available in the countries indicated:

Europe and Northern Asia 040-160.1, 040-250.1, 050-315.1

Europe 040-200.1, 050-160.1, 050-200.1, 050-250.1, 080-200.1

Dimensions and connections

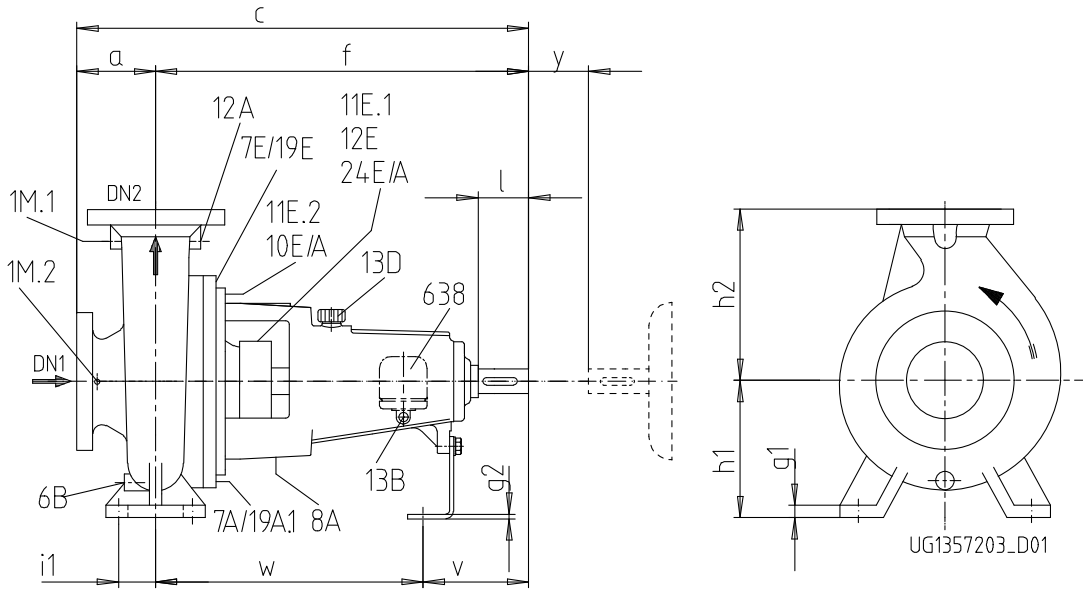

Fig. 3: Dimensions and connections of the pump

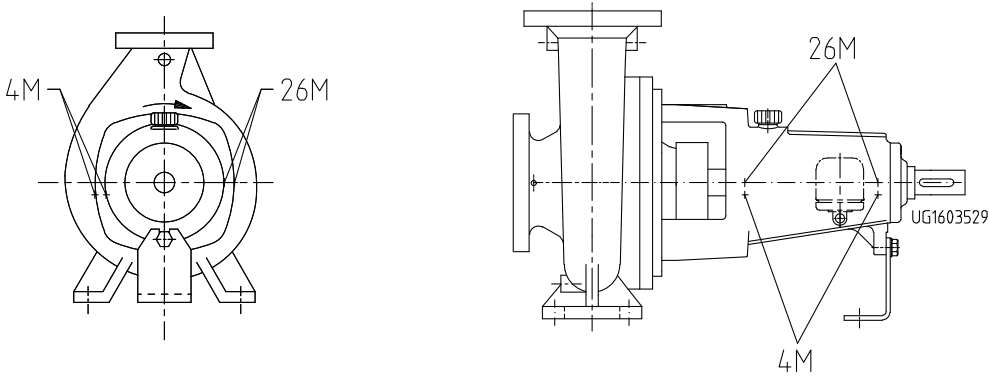

Fig. 4: Connections for shock pulse measurement and temperature measurement

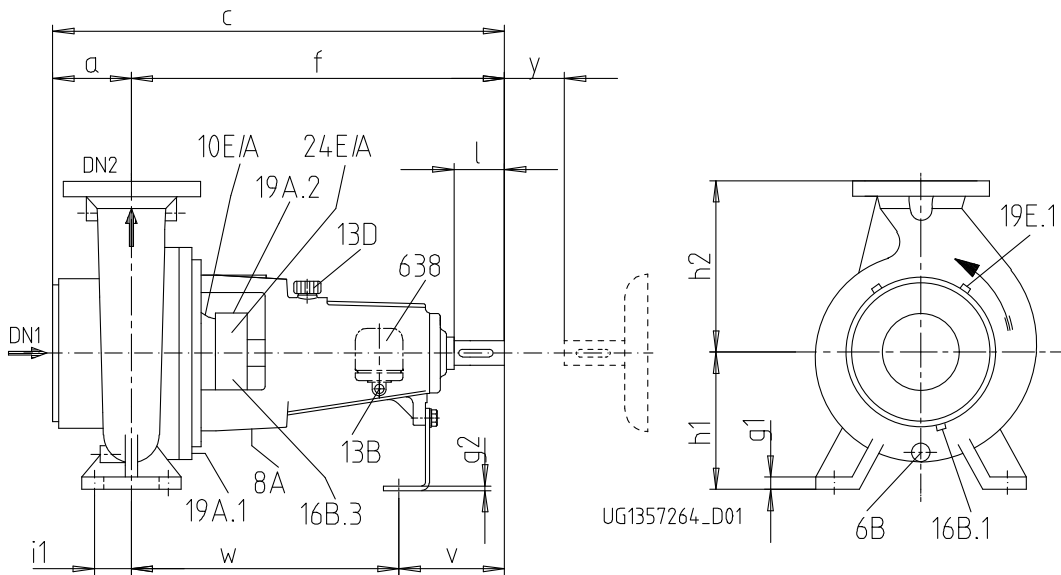

Fig. 5: Dimensions and connections of heatable version

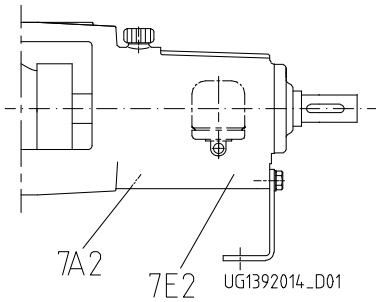

Fig. 6: Connections for version with coolable bearing bracket

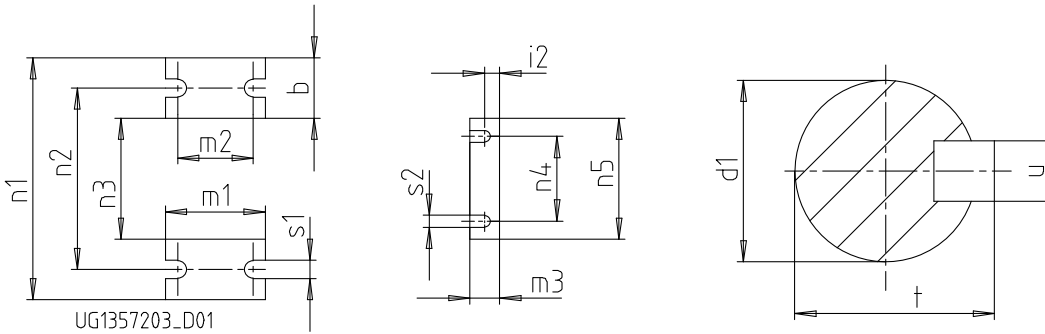
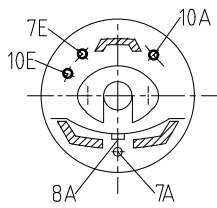
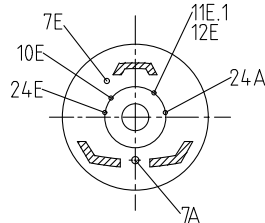

Fig. 7: Dimensions of pump feet and shaft end

Gland packing



Single mechanical seal



Double mechanical seal

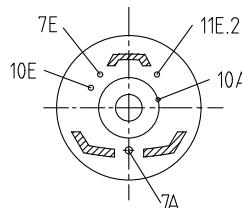

Heatable single mechanical seal

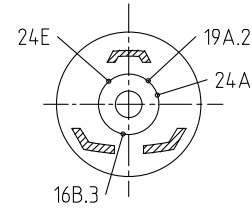

Shaft seal connections

Connections Northern Asia / Europe

Connection	Discharge nozzle			Description
	≤ DN 50	DN 65 - DN 80	≥ DN 100	
1M.1	G1/4	G3/8	G1/2	Pressure gauge
1M.2	G1/4	G3/8	G1/2	Pressure gauge
4M		G1/4		Temperature measuring instrument
6B	G1/4	G3/8	G1/2	Fluid drain
7E/A ²³⁾		Ø 12 (CS40: Ø 8)		Cooling liquid IN/OUT
7E2/A2 ²³⁾		G1 (CS40: G3/4)		Cooling liquid IN/OUT
8A ²³⁾		Rp1/2		Leakage drain
10E/A		G1/4		Barrier fluid IN/OUT
11E.1		G1/4		Flushing liquid IN
11E.2		G1/4		Flushing liquid IN
12E		G1/4		Circulation liquid IN
12A	G1/4	G3/8	G1/2	Circulation liquid OUT
13B		G3/8		Oil drain
13D		Ø 20		Vent plug
16B.1		G1/4		Condensate drain
16B.3		G1/4		Condensate drain
19E		Ø 12 (CS40: Ø 8)		Heating medium IN
19E.1		G3/8		Heating medium IN
19A.1		Ø 12 (CS40: Ø 8)		Heating medium OUT

23) Optional

Connection	Discharge nozzle			Description
	≤ DN 50	DN 65 - DN 80	≥ DN 100	
19A.2		G3/8		Heating medium OUT
24E/A		G1/4		Quench fluid IN/OUT
26M		M8		Vibration measurement
638		Rp1/4		Constant level oiler

Connections Southern Asia

Connection	Discharge nozzle			Description
	≤ DN 50	DN 65 - DN 80	≥ DN 100	
1M.1	G1/4 ²⁴⁾	G3/8 ²⁴⁾	G1/2 ²⁴⁾	Pressure gauge
1M.2	G1/4 ²⁴⁾	G3/8 ²⁴⁾	G1/2 ²⁴⁾	Pressure gauge
4M		NPT1/4		Temperature measuring instrument
6B	G1/4 ²⁴⁾	G3/8 ²⁴⁾	G1/2 ²⁴⁾	Fluid drain
7E/A ²³⁾		Ø 12 (CS40: Ø 8)		Cooling liquid IN/OUT
7E2/A2 ²³⁾		G1 (CS40: G3/4) ²⁴⁾		Cooling liquid IN/OUT
8A ²³⁾		Rp1/2		Leakage drain
10 E/A		G1/4 ²⁴⁾		Barrier fluid IN/OUT
11 E.1		G1/4 ²⁴⁾		Flushing liquid IN
11 E.2		G1/4 ²⁴⁾		Flushing liquid IN
12 E		G1/4 ²⁴⁾		Circulation liquid IN
12A	G1/4 ²⁴⁾	G3/8 ²⁴⁾	G1/2 ²⁴⁾	Circulation liquid OUT
13B		G3/8		Oil drain
13D		Ø 20		Vent plug
16B.1		G1/4		Condensate drain
16B.3		G1/4		Condensate drain
19E		Ø 12 (CS40: Ø 8)		Heating medium IN
19E.1		G3/8		Heating medium IN
19A.1		Ø 12 (CS40: Ø 8)		Heating medium OUT
19A.2		G3/8		Heating medium OUT
24E/A		G1/4 ²⁴⁾²⁵⁾		Quench fluid IN/OUT
26M		M8		Vibration measurement
638		Rp1/4		Constant level oiler

Connections Americas

Connection	Discharge nozzle			Description
	≤ DN 50	DN 65 - DN 80	≥ DN 100	
1M.1	NPT1/4	NPT1/4	NPT1/4	Pressure gauge
1M.2	NPT1/4	NPT1/4	NPT1/4	Pressure gauge
4M		NPT 1/4		Temperature measuring instrument
6B	NPT1/4	NPT3/8	NPT1/2	Fluid drain
7E/A ²³⁾		Ø 12 (CS40: Ø 8)		Cooling liquid IN/OUT
7E2/A2 ²³⁾		NPT1 (CS40: NPT3/4)		Cooling liquid IN/OUT
8A ²³⁾		Rp1/2		Leakage drain
10E/A		NPT1/4		Barrier fluid IN/OUT
11E.1		NPT1/4		Flushing liquid IN
11E.2		NPT1/4		Flushing liquid IN
12E		NPT1/4		Circulation liquid IN
12A	NPT1/4	NPT1/4	NPT1/4	Circulation liquid OUT
13B		NPT1/4 (CS80: NPT1/2)		Oil drain
13D		Ø 20		Vent plug
16B.1		G1/4		Condensate drain
16B.3		G1/4		Condensate drain
19E		Ø 12 (CS40: Ø 8)		Heating medium IN
19E.1		G3/8		Heating medium IN

24) Material variant G is designed with a G thread; material variant C is designed with an NPT thread.

25) Cartridge mechanical seals generally with NPT thread

Connection	Discharge nozzle			Description
	≤ DN 50	DN 65 - DN 80	≥ DN 100	
19A.1	Ø 12 (CS40: Ø 8)			Heating medium OUT
19A.2	G3/8			Heating medium OUT
24E/A	NPT1/4			Quench fluid IN/OUT
26M	M8			Vibration measurement
638	NPT1/4			Constant level oiler

Pump dimensions

Size	Bearing bracket	Pump dimensions [mm]														
		DN1	DN2	a	b	c	f	g1	g2	h1	h2	m1	m3	n1	n3	n5
040-025-160	CS40	40	25	80	50	465	385	15	4	132	160	100	48	240	140	160
040-025-200	CS40	40	25	80	50	465	385	15	4	160	180	100	48	240	140	160
050-032-125	CS40	50	32	80	50	465	385	15	4	112	140	100	48	190	90	160
050-032-125.1	CS40	50	32	80	50	465	385	15	4	112	140	100	48	190	90	160
050-032-160	CS40	50	32	80	50	465	385	15	4	132	160	100	48	240	140	160
050-032-160.1	CS40	50	32	80	50	465	385	15	4	132	160	100	48	240	140	160
050-032-200	CS40	50	32	80	50	465	385	18	4	160	180	100	48	240	140	160
050-032-200.1	CS40	50	32	80	50	465	385	18	4	160	180	100	48	240	140	160
050-032-250	CS50	50	32	100	65	600	500	18	4	180	225	125	48	320	190	160
050-032-250.1	CS50	50	32	100	65	600	500	18	4	180	225	125	48	320	190	160
065-040-125	CS40	65	40	80	50	465	385	15	4	112	140	100	48	210	110	160
065-040-160	CS40	65	40	80	50	465	385	15	4	132	160	100	48	240	140	160
065-040-160.1	CS40	65	40	80	50	465	385	15	4	132	160	100	48	240	140	160
065-040-200	CS40	65	40	100	50	485	385	18	4	160	180	100	48	265	165	160
065-040-200.1	CS40	65	40	100	50	485	385	15	4	160	180	100	48	265	165	160
065-040-250	CS50	65	40	100	65	600	500	18	4	180	225	125	48	320	190	160
065-040-250.1	CS50	65	40	100	65	600	500	18	4	180	225	125	48	320	190	160
065-040-315	CS50	65	40	125	65	625	500	18	6	200	250	125	48	345	215	160
080-050-125	CS40	80	50	100	50	485	385	18	4	132	160	100	48	240	140	160
080-050-160	CS40	80	50	100	50	485	385	18	4	160	180	100	48	265	165	160
080-050-160.1	CS40	80	50	100	50	485	385	15	4	160	180	100	48	262	162	160
080-050-200	CS40	80	50	100	50	485	385	18	4	160	200	100	48	265	165	160
080-050-200.1	CS40	80	50	100	50	485	385	15	4	160	200	100	48	265	165	160
080-050-250	CS50	80	50	125	65	625	500	18	4	180	225	125	48	320	190	160
080-050-250.1	CS50	80	50	125	65	625	500	18	4	180	225	125	48	320	190	160
080-050-315	CS50	80	50	125	65	625	500	18	6	225	280	125	48	345	215	160
080-050-315.1	CS50	80	50	125	65	625	500	18	6	225	280	125	48	345	215	160
100-065-125	CS40	100	65	100	65	485	385	18	4	160	180	125	48	280	150	160
100-065-160	CS50	100	65	100	65	600	500	18	4	160	200	125	48	280	150	160
100-065-200	CS50	100	65	100	65	600	500	18	4	180	225	125	48	320	190	160
100-065-250	CS50	100	65	125	80	625	500	20	6	200	250	160	48	360	200	160
100-065-315	CS60	100	65	125	80	655	530	20	6	225	280	160	48	400	240	160
125-080-160	CS50	125	80	125	65	625	500	18	4	180	225	125	48	320	190	160
125-080-200	CS50	125	80	125	65	625	500	18	4	180	250	125	48	345	215	160
125-080-200.1	CS50	125	80	125	65	625	500	18	4	180	250	125	48	345	215	160
125-080-250	CS50	125	80	125	80	625	500	18	6	225	280	160	48	400	240	160
125-100-160	CS50	125	100	125	80	625	500	18	6	200	280	160	48	360	200	160
125-100-200	CS50	125	100	125	80	625	500	18	6	200	280	160	48	360	200	160
125-080-315	CS60	125	80	125	80	655	530	20	6	250	315	160	48	400	240	160
125-080-400	CS60	125	80	125	80	655	530	20	6	280	355	160	48	435	275	160
125-100-250	CS60	125	100	140	80	670	530	18	6	225	280	160	48	400	240	160
125-100-315	CS60	125	100	140	80	670	530	18	6	250	315	160	48	400	240	160
125-100-400	CS60	125	100	140	100	670	530	20	6	280	355	200	48	500	300	160
150-125-200	CS60	150	125	140	80	670	530	20	6	250	315	160	48	400	240	160
150-125-250	CS60	150	125	140	80	670	530	20	6	250	355	160	48	400	240	160
150-125-315	CS60	150	125	140	100	670	530	20	6	280	355	200	48	500	300	160
150-125-400	CS60	150	125	140	100	670	530	20	6	315	400	200	48	500	300	160
200-150-200	CS60	200	150	180	100	710	530	20	6	280	400	200	48	550	350	160

Size	Bearing bracket	Pump dimensions [mm]														
		DN1	DN2	a	b	c	f	g1	g2	h1	h2	m1	m3	n1	n3	n5
200-150-250	CS60	200	150	160	100	690	530	20	6	280	375	200	48	500	300	160
200-150-315	CS80	200	150	160	100	830	670	20	8	315	400	200	60	550	350	200
200-150-400	CS80	200	150	160	100	830	670	20	8	315	450	200	60	550	350	200
200-150-500	CS80	200	150	180	100	850	670	22	8	375	500	200	60	550	350	200
200-200-250	CS80	200	200	180	100	850	670	22	8	355	425	200	60	550	350	200
250-200-315	CS80	250	200	200	100	870	670	22	8	355	450	200	60	550	350	200
250-200-400	CS80	250	200	180	100	850	670	22	8	355	500	200	60	550	350	200
250-200-500	CS80	250	200	200	100	870	670	22	8	425	560	200	60	660	460	200
300-250-315	CS80	300	250	250	130	920	670	26	8	400	560	260	60	690	430	200

Dimensions of pump feet and shaft end

Size	Bearing bracket	Shaft end [mm]					Pump feet [mm]									
		d1	l	t	u	y	i1	i2	m2	n2	n4	s1	s2	v	w	
040-025-160	CS40	24	50	27	8	100	35	20	70	190	110	14	14	100	285	
040-025-200	CS40	24	50	27	8	100	35	20	70	190	110	14	14	100	285	
050-032-125	CS40	24	50	27	8	100	35	20	70	140	110	14	14	100	285	
050-032-125.1	CS40	24	50	27	8	100	35	20	70	140	110	14	14	100	285	
050-032-160	CS40	24	50	27	8	100	35	20	70	190	110	14	14	100	285	
050-032-160.1	CS40	24	50	27	8	100	35	20	70	190	110	14	14	100	285	
050-032-200	CS40	24	50	27	8	100	35	20	70	190	110	14	14	100	285	
050-032-200.1	CS40	24	50	27	8	100	35	20	70	190	110	14	14	100	285	
050-032-250	CS50	32	80	35	10	100	47,5	20	95	250	110	14	14	130	370	
050-032-250.1	CS50	32	80	35	10	100	47,5	20	95	250	110	14	14	130	370	
065-040-125	CS40	24	50	27	8	100	35	20	70	160	110	14	14	100	285	
065-040-160	CS40	24	50	27	8	100	35	20	70	190	110	14	14	100	285	
065-040-160.1	CS40	24	50	27	8	100	35	20	70	190	110	14	14	100	285	
065-040-200	CS40	24	50	27	8	100	35	20	70	212	110	14	14	100	285	
065-040-200.1	CS40	24	50	27	8	100	35	20	70	212	110	14	14	100	285	
065-040-250	CS50	32	80	35	10	100	47,5	20	95	250	110	14	14	130	370	
065-040-250.1	CS50	32	80	35	10	100	47,5	20	95	250	110	14	14	130	370	
065-040-315	CS50	32	80	35	10	100	47,5	20	95	280	110	14	14	130	370	
080-050-125	CS40	24	50	27	8	100	35	20	70	190	110	14	14	100	285	
080-050-160	CS40	24	50	27	8	100	35	20	70	212	110	14	14	100	285	
080-050-160.1	CS40	24	50	27	8	100	35	20	70	212	110	14	14	100	285	
080-050-200	CS40	24	50	27	8	100	35	20	70	212	110	14	14	100	285	
080-050-200.1	CS40	24	50	27	8	100	35	20	70	212	110	14	14	100	285	
080-050-250	CS50	32	80	35	10	100	47,5	20	95	250	110	14	14	130	370	
080-050-250.1	CS50	32	80	35	10	100	47,5	20	95	250	110	14	14	130	370	
080-050-315	CS50	32	80	35	10	100	47,5	20	95	280	110	14	14	130	370	
080-050-315.1	CS50	32	80	35	10	100	47,5	20	95	280	110	14	14	130	370	
100-065-125	CS40	24	50	27	8	100	47,5	20	95	212	110	14	14	100	285	
100-065-160	CS50	32	80	35	10	100	47,5	20	95	212	110	14	14	130	370	
100-065-200	CS50	32	80	35	10	140	47,5	20	95	250	110	14	14	130	370	
100-065-250	CS50	32	80	35	10	140	60	20	120	280	110	18	14	130	370	
100-065-315	CS60	42	110	45	12	140	60	20	120	315	110	18	14	160	370	
125-080-160	CS50	32	80	35	10	140	47,5	20	95	250	110	14	14	130	370	
125-080-200	CS50	32	80	35	10	140	47,5	20	95	280	110	14	14	130	370	
125-080-200.1	CS50	32	80	35	10	140	47,5	20	95	280	110	14	14	130	370	
125-080-250	CS50	32	80	35	10	140	60	20	120	315	110	18	14	130	370	
125-080-315	CS60	42	110	45	12	140	60	20	120	315	110	18	14	160	370	
125-080-400	CS60	42	110	45	12	140	60	20	120	355	110	18	14	160	370	
125-100-160	CS50	32	80	35	10	140	60	20	120	280	110	19	14	130	370	
125-100-200	CS50	32	80	35	10	140	60	20	120	280	110	18	14	130	370	
125-100-250	CS60	42	110	45	12	140	60	20	120	315	110	18	14	160	370	
125-100-315	CS60	42	110	45	12	140	60	20	120	315	110	18	14	160	370	
125-100-400	CS60	42	110	45	12	140	75	20	150	400	110	23	14	160	370	

Size	Bearing bracket	Shaft end [mm]					Pump feet [mm]									
		d1	l	t	u	y	i1	i2	m2	n2	n4	s1	s2	v	w	
150-125-200	CS60	42	110	45	12	140	60	20	120	315	110	19	14	160	370	
150-125-250	CS60	42	110	45	12	140	60	20	120	315	110	18	14	160	370	
150-125-315	CS60	42	110	45	12	140	75	20	150	400	110	23	14	160	370	
150-125-400	CS60	42	110	45	12	140	75	20	150	400	110	23	14	160	370	
200-150-200	CS60	42	110	45	12	180	75	20	150	450	110	24	14	160	370	
200-150-250	CS60	42	110	45	12	180	75	20	150	400	110	23	14	160	370	
200-150-315	CS80	48	110	51	14	180	75	39	150	450	140	23	18	170	500	
200-150-400	CS80	48	110	51	14	180	75	39	150	450	140	23	18	170	500	
200-150-500	CS80	48	110	51	14	180	75	39	150	450	140	23	18	170	500	
200-200-250	CS80	48	110	51	14	180	75	39	150	450	140	23	18	170	500	
250-200-315	CS80	48	110	51	14	180	75	39	150	450	140	23	18	170	500	
250-200-400	CS80	48	110	51	14	180	75	39	150	450	140	23	18	170	500	
250-200-500	CS80	48	110	51	14	180	75	39	150	560	140	23	18	170	500	
300-250-315	CS80	48	110	51	14	180	95	39	190	560	140	28	18	170	500	

Flange design

Flange design by materials

Material	Europe / Northern Asia / Americas / Southern Asia	Americas
G	EN 1092-2 PN 16 Drilled to ASME B16.1 Class 125	ASME B16.1 Class 125 ASME B16.1 Class 250 ²⁶⁾
C/F	EN 1092-1 PN 16 Drilled to ASME B16.5 Class 150	ASME B16.5 Class 150
V	EN 1092-1 PN 16 Drilled to ASME B16.5 Class 150	-
D/O	EN 1092-1 PN 25 Drilled to ASME B16.5 Class 150 Drilled to ASME B16.5 Class 300 ²⁷⁾	-
E	EN 1092-1 PN 25 Drilled to ASME B16.5 Class 150 Drilled to ASME B16.5 Class 300 ²⁷⁾	ASME B16.5 Class 150 ASME B16.5 Class 300 ²⁶⁾

Scope of supply

Depending on the model, the following items are included in the scope of supply:

- Pump

Drive

- Surface-cooled IEC frame three-phase squirrel-cage motor

Coupling

- Flexible coupling with or without spacer

Contact guard

- Coupling guard

Baseplate

- Baseplate (to ISO 3661), cast or welded, for pump and motor, in torsion-resistant design
- Channel section steel or folded steel plate

Special accessories

- As required

26) Depending on the size

27) Not possible for size 100-065-125

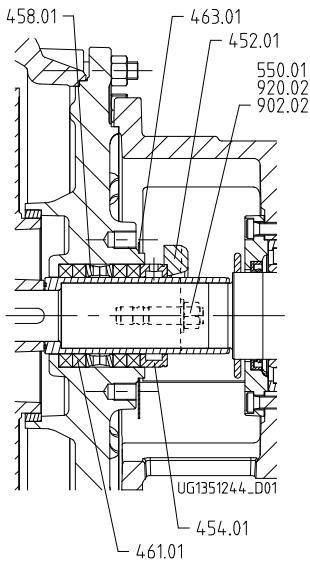

Version with gland packing

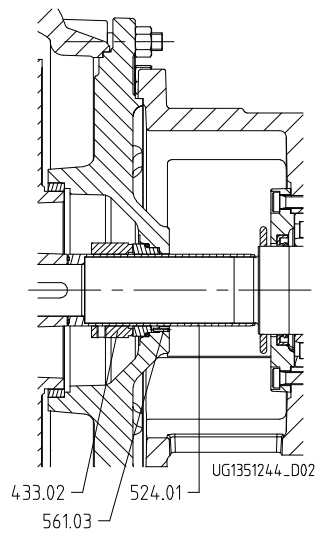

Mechanical seal with conical casing cover

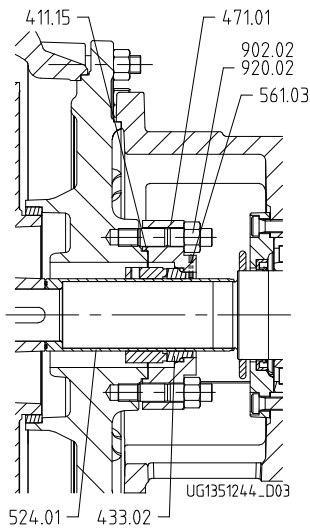

Mechanical seal with cylindrical casing cover

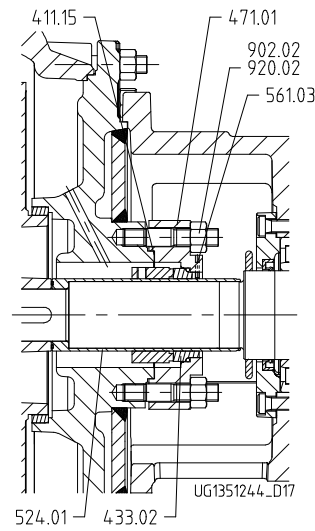

Mechanical seal with cylindrical casing cover
(heatable version with welded casing cover)

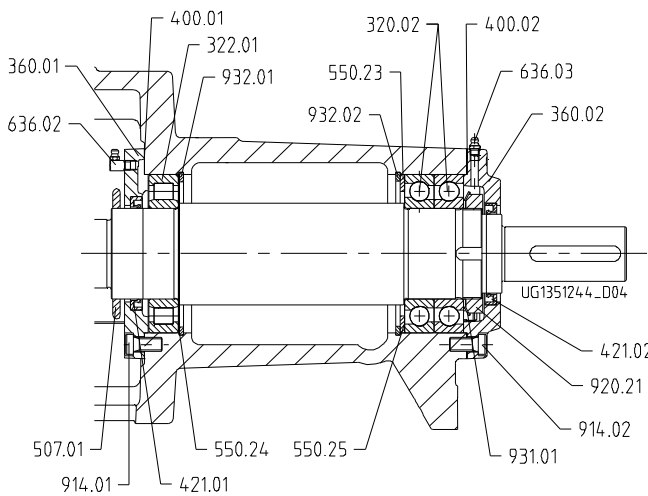

Grease-lubricated version (medium-duty bearing assembly)

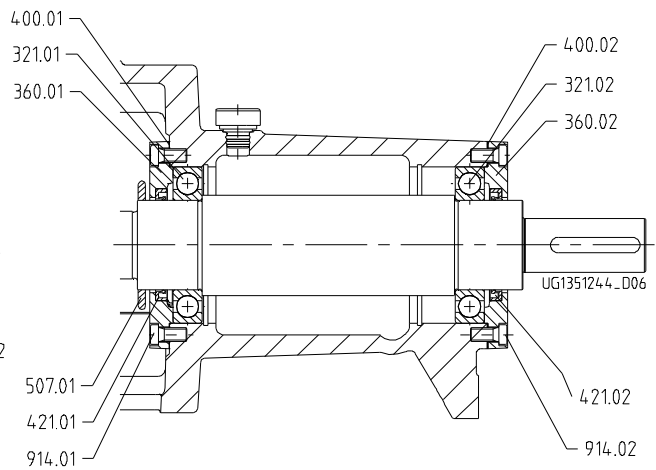

Oil-lubricated version (economy bearing assembly)

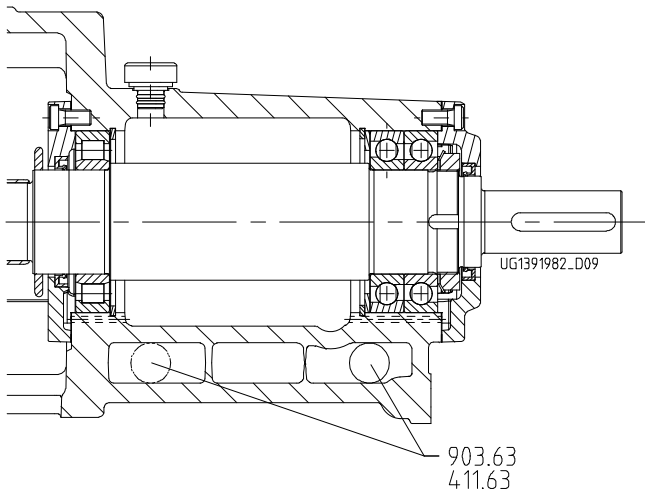

Version with coolable bearing bracket

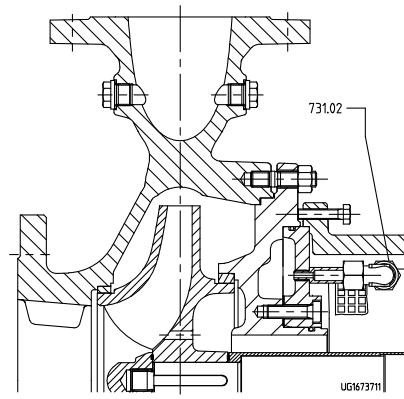

Heatable version, only casing cover cooled/heated

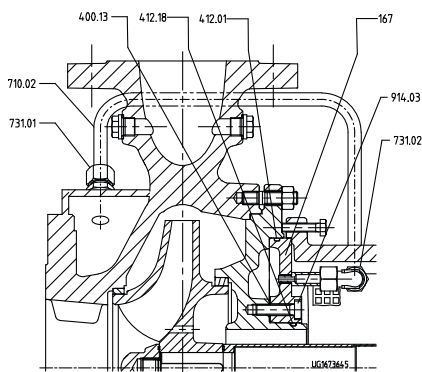

Heatable version with bolted casing cover

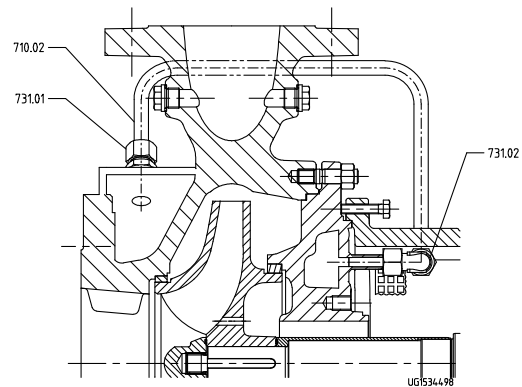

Heatable version with welded casing cover

List of components

Part No.	Comprising	Description
102	102	Volute casing
	411.01/.02 ²⁸⁾ /03 ²⁸⁾ /.04 ²⁸⁾ /.10 ²⁹⁾	Joint ring
	502.01 ²⁸⁾	Casing wear ring
	902.01	Stud
	903.01/.02 ²⁸⁾ /.03 ²⁸⁾ /.04 ²⁸⁾	Screw plug
	920.01	Hexagon nut
161	161	Casing cover
	167 ³⁰⁾	Cover insert
	400.13 ³⁰⁾	Gasket
	412.01/.18 ³⁰⁾	O-ring
	502.02 ²⁸⁾	Casing wear ring
	901.22 ³¹⁾ /31	Hexagon head bolt
	902.02	Stud
	914.03 ³⁰⁾	Hexagon socket head cap screw
	920.02	Hexagon nut
183	183	Support foot
210	210	Shaft
	920.21 ³²⁾	Slotted round nut
	931.01 ³²⁾	Lock washer

28) Not on all versions

29) Joint rings 411.10 and 411.15 (411.15 for versions with mechanical seal with seal cover only) depending on the operating temperature. Order separately in spare parts order.

30) On versions with bolted casing cover only

31) On versions with clamped casing cover only

32) Not fitted on versions with economy bearing assembly

Part No.	Comprising	Description
210	940.01/.02/.09 ³³⁾	Key
230	230	Impeller
	503.01/.02 ²⁸⁾	Impeller wear ring
320.02 ³²⁾	320.02	Angular contact ball bearing (double-row in CS40)
321.01 ³⁴⁾	321.01	Deep groove ball bearing
321.02 ³⁴⁾	321.02	Deep groove ball bearing
322.01 ³²⁾	322.01	Cylindrical roller bearing
330	330	Bearing bracket
360.01	360.01	Bearing cover
360.02	360.02	Bearing cover
400.01	400.01	Gasket
400.02	400.02	Gasket
411.15 ²⁹⁾	411.15	Joint ring
411.31	411.31	Joint ring
411.32	411.32	Joint ring
421.01	421.01	Lip seal
421.02	421.02	Lip seal
433.02	433.02	Mechanical seal (complete)
452.01	452.01	Gland follower
454.01	454.01	Stuffing box ring
458.01	458.01	Lantern ring
461.01	461.01	Gland packing
463.01	463.01	Drip plate
471.01	471.01	Seal cover
502.01 ²⁸⁾	502.01	Casing wear ring
502.02 ²⁸⁾	502.02	Casing wear ring
503.01 ²⁸⁾	503.01	Impeller wear ring
503.02 ²⁸⁾	503.02	Impeller wear ring
507.01	507.01	Thrower
507.02 ³⁵⁾	507.02	Thrower
524.01	524.01	Shaft protecting sleeve
550.01	550.01	Disc
550.23	550.23	Disc
550.24 ³⁶⁾	550.24	Disc
550.25 ³⁶⁾	550.25	Disc
550.74	550.74	Disc
554.98	554.98	Washer
561.03	561.03	Grooved pin
636.02 ³⁶⁾	636.02	Lubricating nipple
636.03 ³⁶⁾	636.03	Lubricating nipple
638 ³⁷⁾	638	Constant level oiler
642 ³⁷⁾	642	Oil level sight glass
672 ³⁷⁾	672	Vent plug
81-92	81-92	Cover plate
99-9	411.01/.02/.03/.04/.10/.15/31/.32/.46	Joint ring
	400.01/02	Gasket
901.04	901.04	Hexagon head bolt
901.30	901.30	Hexagon head bolt
901.31	901.31	Hexagon head bolt
901.32	901.32	Hexagon head bolt
901.98	901.98	Hexagon head bolt
902.15	902.15	Stud
903.46	903.46	Screw plug
914.01	914.01	Hexagon socket head cap screw

- 33) From CS60
34) On versions with economy bearing assembly only
35) On versions with labyrinth seal only
36) On grease-lubricated versions only
37) Not applicable for grease-lubricated versions

Part No.	Comprising	Description
914.02	914.02	Hexagon socket head cap screw
920.15	920.15	Hexagon nut
922	922	Impeller nut
932.01	932.01	Circlip
932.02	932.02	Circlip

The relevant version is indicated in the product literature supplied.



KSB SE & Co. KGaA
Johann-Klein-Straße 9 • 67227 Frankenthal (Germany)
Tel. +49 6233 86-0
www.ksb.com

KSB Bombas Hidráulicas S/A
Rua José Rabello Portella, 638
CEP: 13.220-540 - Jardim Maria de Fátima
Várzea Paulista (Brasil)
Tel.: +55 11 4596 8500 • Fax Fax: +55 11 4596 8580
www.ksb.com

KSB Pumps Limited
Plot no. E3 & E4, MIDC, Sinnar, (Malegaon) • Nashik 422 113
Tel. +91 2551 230252
Tel. +91 2551 230253
Tel. +91 2551 229700
Fax +91 2551 230254
www.ksbindia.co.in