

JUNG PUMPEN COMPLI 100 MC SEWAGE LIFTING STATIONS

APPLICATION

The sewage lifting stations compli 100, compli 500 and compli 1000 with MultiCut cutting system are used especially for disposal in special objects, such as weekend cottages, houseboats, toilets in production halls or mobile sanitary facilities.

The MultiCut cutting system enables wastewater to be pumped through long and small-dimensioned pressure pipes to the nearest sewer whereby the pressure pipes can follow the terrain. This type of wastewater transport is more economical in many cases than disposal by gravity sewer. The external cutting system ensures safe operation.

The submersible units are permitted for general use in areas subject to flooding. The control unit has to be fitted in a well ventilated flood-proof room. The PE tanks have freely accessible drains, a top-mounted cleaning opening and a clamp-type inlet flange for an easy installation. The inlet height is variable depending on the type and inlet pipe:

compli 100

- DN 50: 150, 250 mm
- DN 150/DN 50: 180, 275 a. 315 mm

compli 500 and 1000

- DN 100: 180, 250 mm
- DN 100: 180-340 mm.

For the connection of an inlet pipe DN 100 a PVC reducer DN 150/DN 100 is added to the compli 500 and 1000. A vertical inlet neck is mounted on top of the tank for an inlet pipe DN 150 or DN 100. If the rear inlet is not used it must be closed with the sealing set DN 150 (accessory). The duplex units compli 1000 have two pumps, that operate alternately. In case of peak load operation both pumps operate at the same time.

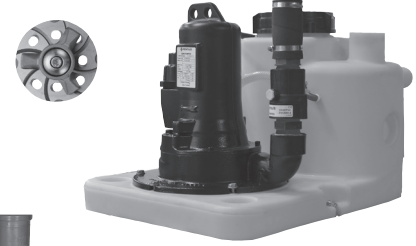

compli 120/2 M

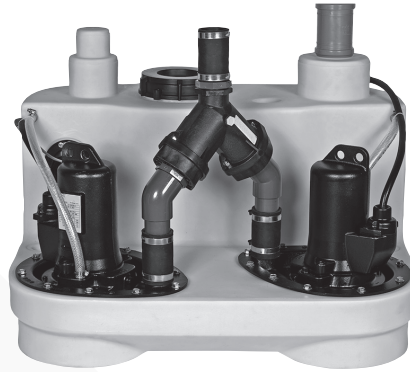

compli 1008/2 ME



- Ready-to-connect
- Submersible
- Clamp type inlet flange
- Versatile connectivity
- Small dimensioned pressure pipe
- High delivery head
- PE tank
- MultiCut cutting system

PERFORMANCE

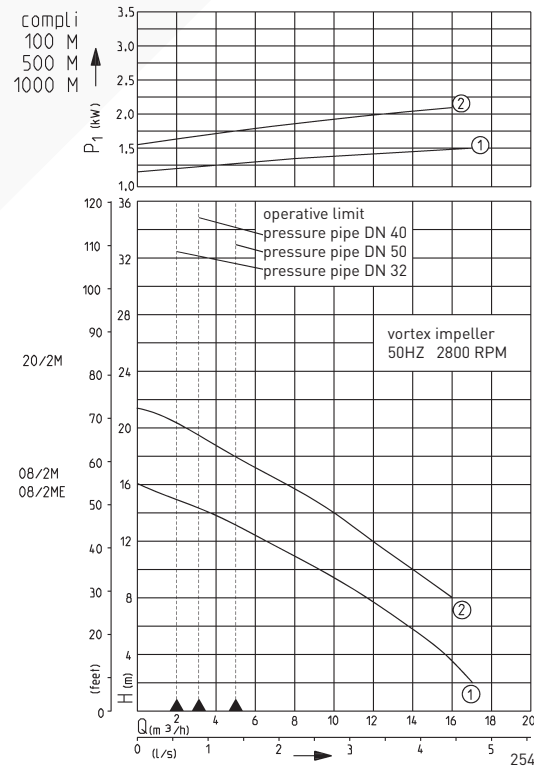

We reserve the right to change specifications without notice Pump performance is subject to ISO 9906 tolerances

The minimum flow velocity in the pressure piping must be 0.7 m/s according to EN 12056. This data is represented in the performance curve as a limit of application.

JUNG PUMPEN COMPLI 100 MC

SEWAGE LIFTING STATIONS

SEWAGE LIFTING STATIONS

Type	Tank capacity l	Inlet height mm	Free passage	Clamp type inlet flange	Discharge branch	Connection pipe external Ø	Ventilation	Weight approx.	Code No.
compli 108/2 ME	38	180/250	7 mm	DN 100	DN 50	63 mm	DN 70	42.0 kg	JP09347
compli 108/2 M	38	180/250	7 mm	DN 100	DN 50	63 mm	DN 70	41.0 kg	JP09346
compli 120/2 M	38	180/250	7 mm	DN 100	DN 50	63 mm	DN 70	43.0 kg	JP09877
compli 508/2 ME	115	variabel	7 mm	DN 150	DN 40	50 mm	DN 70	50.0 kg	JP43128
compli 508/2 M	115	variabel	7 mm	DN 150	DN 40	50 mm	DN 70	49.0 kg	JP43129
compli 520/2 M	115	variabel	7 mm	DN 150	DN 40	50 mm	DN 70	51.0 kg	JP43130
compli 1008/2 ME	115	variabel	7 mm	DN 150	DN 40	50 mm	DN 70	77.0 kg	JP43131
compli 1008/2 M	115	variabel	7 mm	DN 150	DN 40	50 mm	DN 70	75.0 kg	JP43132
compli 1020/2 M	115	variabel	7 mm	DN 150	DN 40	50 mm	DN 70	79.0 kg	JP43133

PERFORMANCE

Type	Delivery head H [m]	2	4	6	8	10	12	14	16	18	20	22	24	26	28	30	32	34
compli ...08/2 M E	Delivery date Q [m³/h]	17	16	14	12	9	7	4										
compli ...08/2 M		17	16	14	12	9	7	4										
compli ...20/2 M					16	14	12	10	8	5	3							

ELECTRICAL DATA

Type	Type of current	Voltage Volt	Motor rating kW P ₁	P ₂	Current Amp.	Cable (4 m) Tankcontrol	Cable (1.5 m) Controlplug	Plug
compli ...08/2 ME	1-phase	1/N/PE~230	1.70	1.14	7.5	H 07 RN-F-6 G 1.5	H 05 VV-F-3 G 1.5	Safety-
compli ...08/2 M	3-phase	3/N/PE~400	1.65	1.24	2.8	H 07 RN-F-6 G 1.5	H 05 VV-F-5 G 1.5	CEE-
compli ...20/2 M	3-phase	3/N/PE~400	2.30	1.85	3.9	H 07 RN-F-6 G 1.5	H 05 VV-F-5 G 1.5	CEE-

In keeping with the construction and testing principles of German / European standard DIN EN 12050, sewage lifting stations are used for the transport of faecal matter and domestic wastewater in building drainage systems as described in German standard DIN 1983 T3. In keeping with the stipulations of German / European standard DIN EN 12056-4 they have to be mounted with collecting tanks inside building permitting a free space of 60 cm for operation and repair. A non-return valve tested in keeping with German / European standard DIN EN 12050-4 has to be fitted in the pressure pipe.

In keeping with German / European standard 12056 the ventilation pipe has to be passed up to the roof.

Other specifications of German / European standard DIN EN 12056-4, paragraphs 5.1 and 5.2:

- Pump sump for the drainage of the operation room
- Stop valve on the pressure side
- Stop valve on the inlet side
- Disposal units have to be mounted buoyancy-proof.







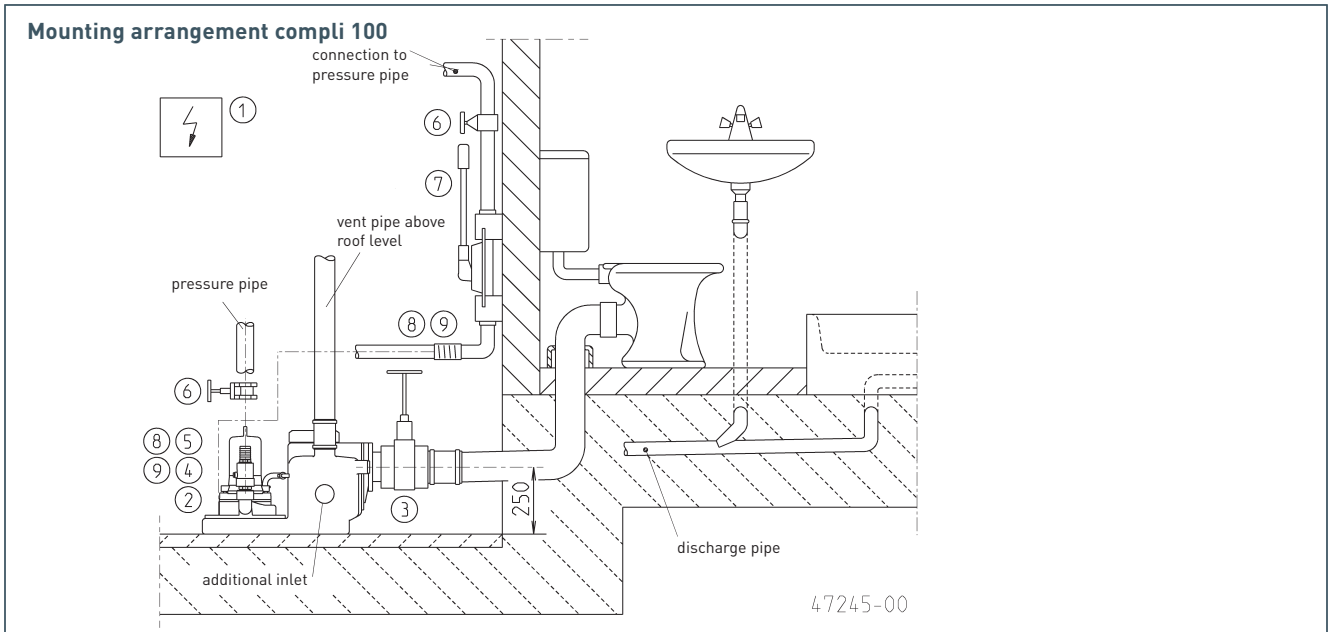

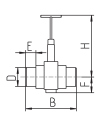

Use in pressurised drainage systems: When compli 100 is used in a pressurised drainage system in keeping with German / European standard 1671, a PN 6 swing-type check valve and a PN 16 system valve have to be installed in the pressure pipe.

JUNG PUMPEN COMPLI 100 MC

SEWAGE LIFTING STATIONS

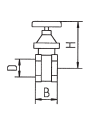

ACCESSORIES COMPLI 100







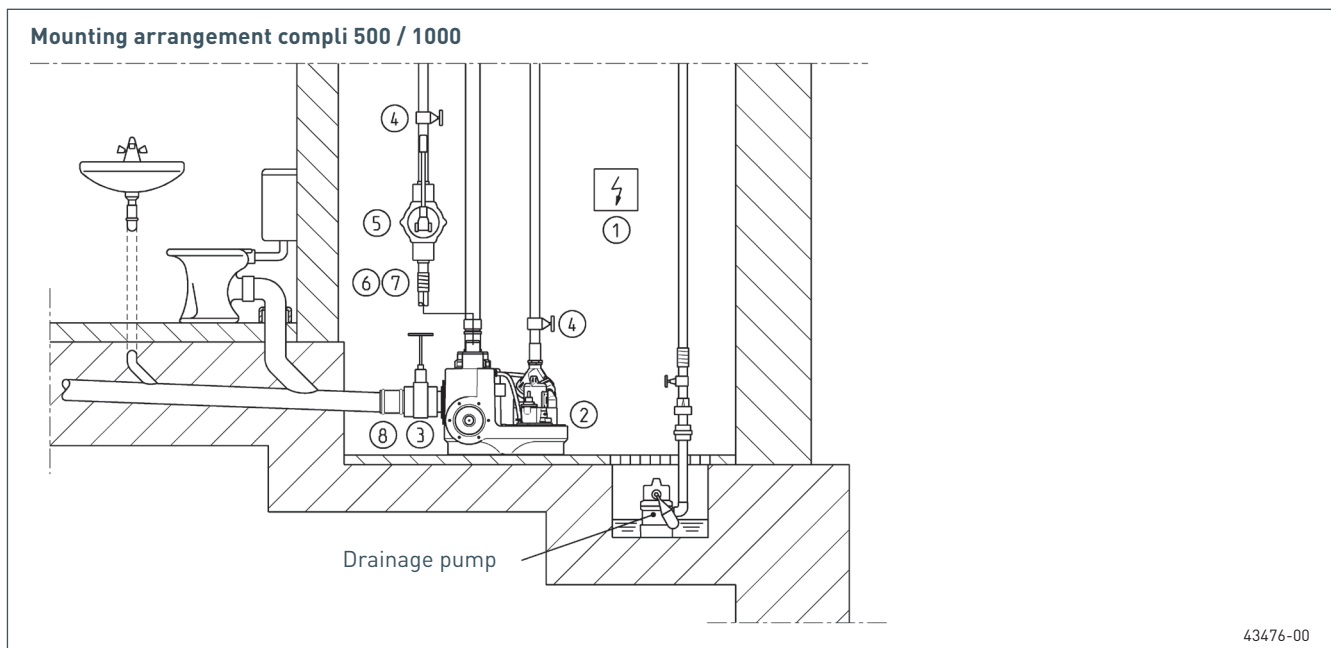

		Code No.												
	1 Rechargeable battery for mains-independent alarm	JP44850												
	2 Seal leak detector DKG	JP44900												
	3 PVC sluice valve (with pipe socket) for 4" inlet (DN 100), PN 1	<table border="1" style="display: inline-table; border-collapse: collapse;"> <thead> <tr> <th>H</th> <th>B</th> <th>E</th> <th>F</th> <th>D</th> </tr> </thead> <tbody> <tr> <td>360</td> <td>295</td> <td>60</td> <td>81</td> <td>110</td> </tr> </tbody> </table> JP28297	H	B	E	F	D	360	295	60	81	110		
H	B	E	F	D										
360	295	60	81	110										
	4 Reducing socket 1 1/4" - 1 1/2" Reducing socket 1 1/4" - 2"	JP44769 JP44772												
	5 Swing-type check valve 1 1/2" (DN 40), PN 4, DIN EN 12050-4 2" (DN 50), PN 4, DIN EN 12050-4	<table border="1" style="display: inline-table; border-collapse: collapse;"> <thead> <tr> <th>H</th> <th>B</th> <th>D</th> </tr> </thead> <tbody> <tr> <td>150</td> <td>120</td> <td>1 1/2"</td> </tr> <tr> <td>150</td> <td>120</td> <td>2"</td> </tr> </tbody> </table> JP00317 JP00326	H	B	D	150	120	1 1/2"	150	120	2"			
H	B	D												
150	120	1 1/2"												
150	120	2"												
	Ball-type check valve K 50, 2" (DN 50), PN 6, DIN EN 12050-4	<table border="1" style="display: inline-table; border-collapse: collapse;"> <thead> <tr> <th>H</th> <th>B</th> <th>D</th> </tr> </thead> <tbody> <tr> <td>185</td> <td>150</td> <td>2"</td> </tr> </tbody> </table> JP44782	H	B	D	185	150	2"						
H	B	D												
185	150	2"												
	6 Stop valve for pressure side, 2" (DN 50), PN 16 1 1/4" (DN 32), PN 16 1 1/2" (DN 40), PN 16 2" (DN 50), PN 16	<table border="1" style="display: inline-table; border-collapse: collapse;"> <thead> <tr> <th>H</th> <th>B</th> <th>D</th> </tr> </thead> <tbody> <tr> <td>110</td> <td>max. 60</td> <td>1 1/4"</td> </tr> <tr> <td>125</td> <td>max. 60</td> <td>1 1/2"</td> </tr> <tr> <td>140</td> <td>max. 67</td> <td>2"</td> </tr> </tbody> </table> JP44785 JP44786 JP44787	H	B	D	110	max. 60	1 1/4"	125	max. 60	1 1/2"	140	max. 67	2"
H	B	D												
110	max. 60	1 1/4"												
125	max. 60	1 1/2"												
140	max. 67	2"												
	7 Hand diaphragm pump (bis H _{geod} 15 m)	<table border="1" style="display: inline-table; border-collapse: collapse;"> <thead> <tr> <th>H</th> <th>E</th> <th>D</th> </tr> </thead> <tbody> <tr> <td>ca. 640</td> <td>430</td> <td>1 1/2"</td> </tr> </tbody> </table> JP00255	H	E	D	ca. 640	430	1 1/2"						
H	E	D												
ca. 640	430	1 1/2"												
	8 Elastic connection 1 1/2" (DN 40), PN 4 2" (DN 50), PN 4	<table border="1" style="display: inline-table; border-collapse: collapse;"> <thead> <tr> <th>H</th> <th>D</th> </tr> </thead> <tbody> <tr> <td>120</td> <td>50</td> </tr> <tr> <td>150</td> <td>63</td> </tr> </tbody> </table> JP44777 JP44775	H	D	120	50	150	63						
H	D													
120	50													
150	63													
	9 Clamp 1 1/2" 2"	JP44763 JP45953												

JUNG PUMPEN COMPLI 100 MC

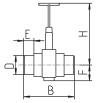
SEWAGE LIFTING STATIONS

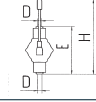

ACCESSORIES COMPLI 500 / 1000

					Code No.			
	1	Rechargeable battery for mains-independent alarm			JP44850			
	2	Seal leak detector DKG			JP44900			
	3	PVC sluice valve (with pipe socket) for inlet 4" [DN 100], PN 1 for inlet 6" [DN 150], PN 2,5	H	B	E	F	D	JP28297 JP28591
	4	Stop valve , 1½" [DN 40], PN 16 for pressure side	H	B	D			JP44786
	5	Hand diaphragm pump (bis H _{geod} 15 m)	H	E	D			JP00255
	6	Elastic connection 1½" [DN 40], PN 4	H	D				JP44777
	7	Clamp 1½"						JP44763
	8	Opening set DN 150						JP43156

JUNG PUMPEN COMPLI 100 MC

SEWAGE LIFTING STATIONS

Dimensions compli 100 M (mm)

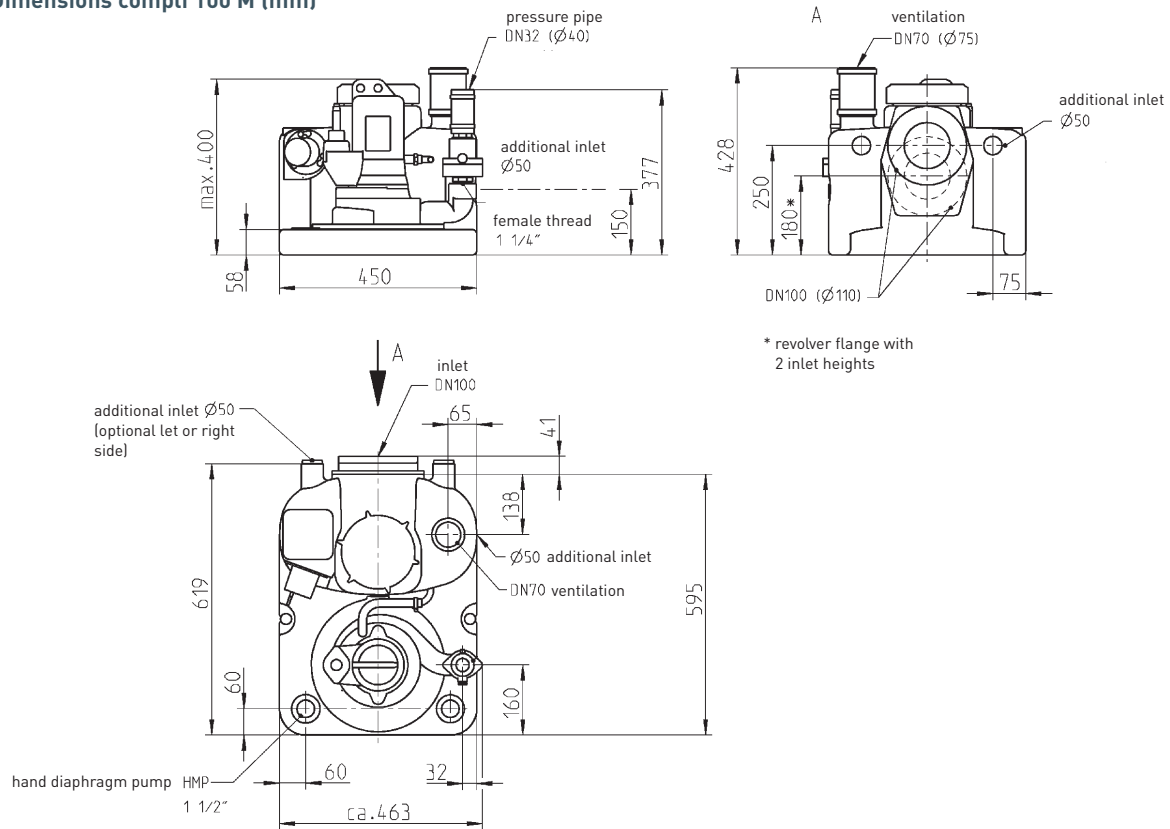

47246-00

Dimensions compli 500 M (mm)

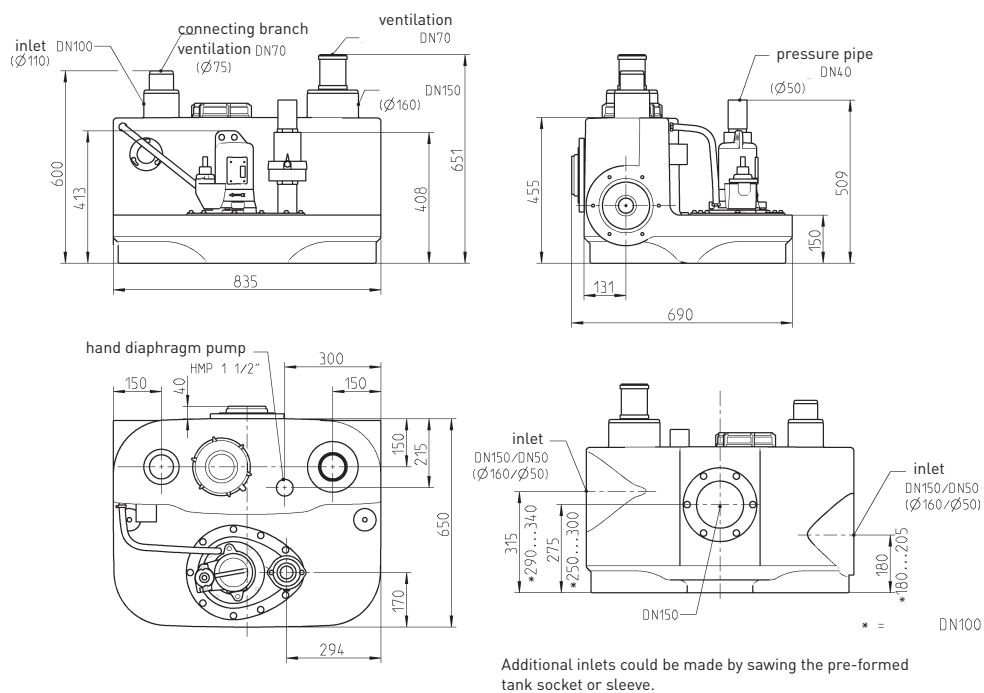

43116-01

JUNG PUMPEN COMPLI 100 MC

SEWAGE LIFTING STATIONS

Dimensions compli 1000 M (mm)

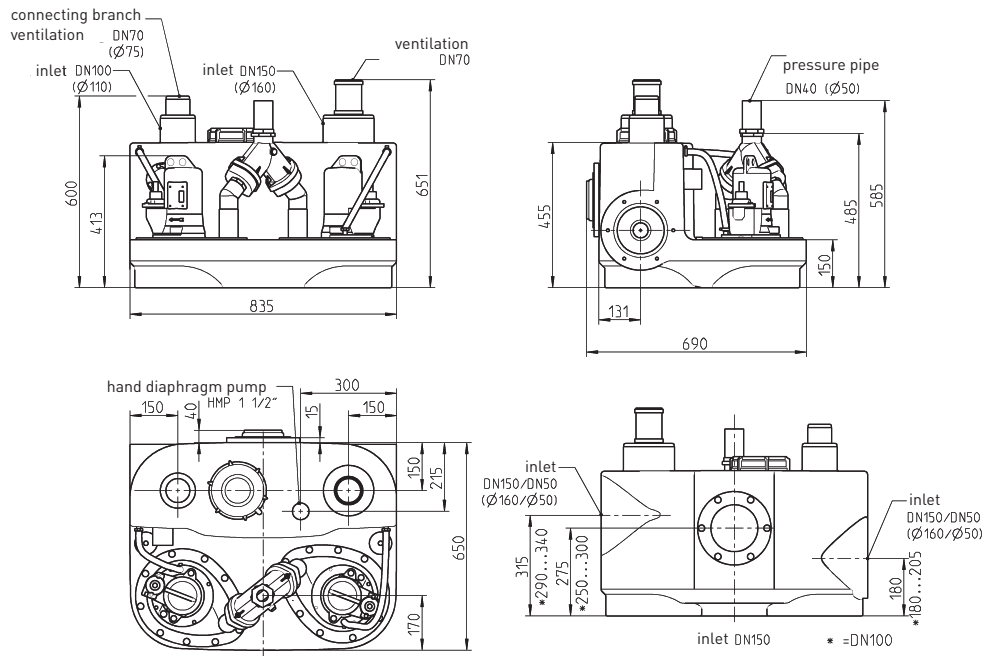

Additional inlets could be made by sawing the pre-formed tank socket or sleeve.

43117-01

TECHNICAL DATA

Pump

Vertical, single-stage, submersible pump housing with DN 50 outlet, open impeller, MultiCut cutting system - adjustable, flanged to PE tank with cleaning opening.

Bearing

Common shaft for pump and motor, grease-packed ball bearing.

Seal

Silicon-carbide mechanical seal independent of the sense of rotation, oil chamber and duplex radial shaft seal towards the motor compartment, safe to run dry.

Motor

Submersible, IP 68 type of protection, insulation class F, winding thermostats for the protection of the drives against overheating, automatic activation through control unit only.

Materials

Tank made of polyethylene; pump and motor housing in grey cast iron GG-25, single-vane impeller made of fibre-glass reinforced plastic; shaft completely covered towards the media, cutting equipment made of hardened stainless steel (57 HRC); rubber inlet hose.

Scope of supply

Ready-to-connect tank system (capacity 38 l respectively 115 l) in keeping with German / European standard 12050 with height-adjustable DN 100 revolver clamping flange for inlet height 180/250 mm for compli 100; compli 500 and 1000 PVC-tube DN 150 (180, 275, 315 mm), DN 100 (180-340 mm), additional horizontal and vertical inlets, diam. 50 mm, adapter DN 150/DN 100, pre-mounted submersible pump, one elastic connection each with clamps for plastic pressure pipes and jointing tube for DN 70 ventilation pipe, mounted non-return valve, automatic float switch circuit, control (IP 44 type of protection) with motor protection, contactor, transformer, mains-dependable optionally acknowledgeable alarm system and potential-free contact for collective failure messages, optical display of sense of direction (three-phase current), alarm and operation, button for test run.

To be fitted with a micro-processor control as well upon request. Cable between tank and control 4 m, cable between control and plug 1.5 m. Accessories to be ordered according to mounting drawing.

MultiCut cutting system

The unique MultiCut cutting system ensures a maximum of operational safety at outstanding delivery characteristics. Fitted with a cutter plate made of hardened stainless steel and a three-bladed knife, it disintegrates coarse additions in the waste-water with more than 62,000 cutting processes per minute before they can get into the pump hydraulics. Solids which cannot be transported are rejected outside of the pump by the cutting rotor as the cutting system is located upstream from the pump hydraulics. Specifically arranged grooves on the cutter plate ensure additional safety as the cutting unit is permanently cleaned automatically during the delivery.

