

Lifting unit for chemically aggressive drainage water from households with floor mounted collection tank

San.iQ plus - CH140 WA

Conveying capacity

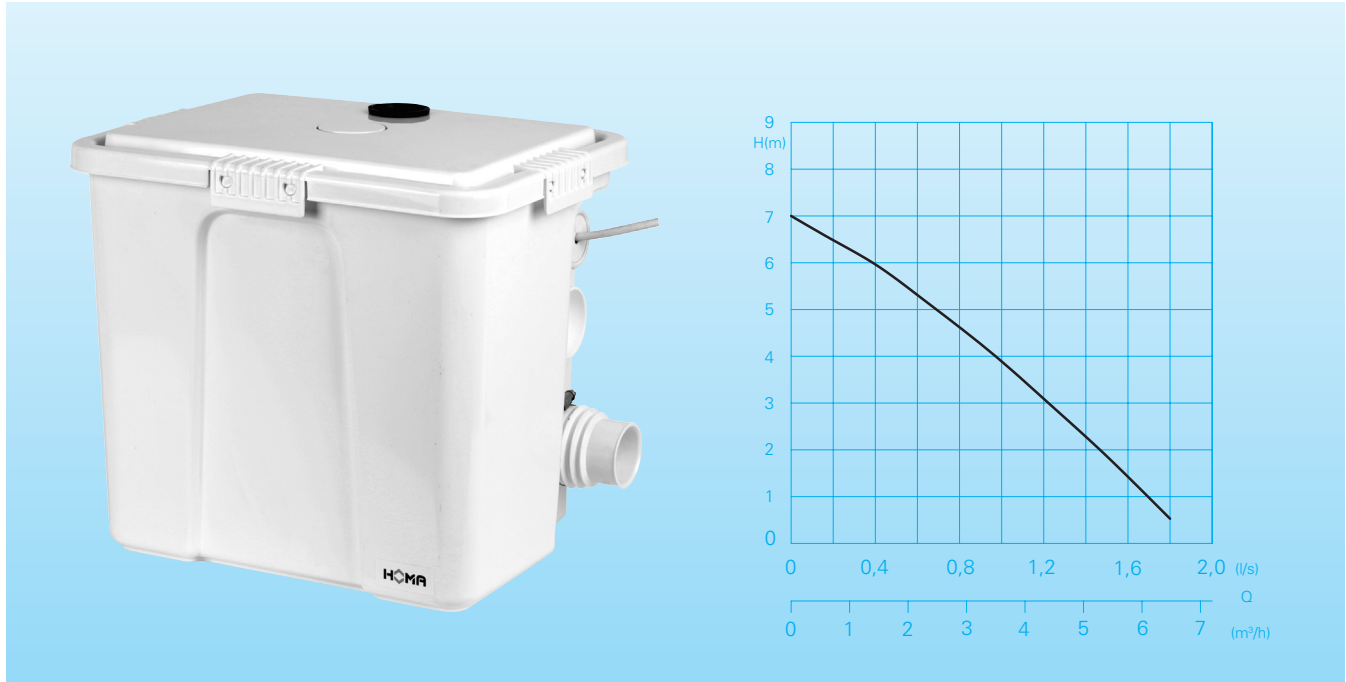

Application

Promotes chemically aggressive drainage water from households, such as salt water (up to 15%), from water softeners and condensate from condensing boilers. The San.iQ plus is also the ideal solution for subsequent installation of sanitary facilities. The built-in powerful drainage pump operates automatically by a floatswitch control. The discharge pipe with \varnothing 40 mm minimum diameter can be easily installed with minimum construction work. The San.iQ plus compact design allows installation directly under the hand basin, where space is at a premium.

DIN EN 12050-2: Design tested and monitored.

Pumped medium: chemically aggressive drainage water & domestic wastewater. Max. temperature of pumped medium: 35°C.

Operating mode: Continuous operation (S1)

Technical data

Curve No.	Type	Motor input		Nominal current (A)	Discharge	Weight (kg)
		P ₁ (kW)	P ₂ (kW)			
①	San.iQ plus- CH140 WA	0,32	0,17	1,4	\varnothing 40 mm	7,0

Rotational speed: 2850 rpm
Cable: H07RN-F 3G1

Model W: 230V/1Ph 50Hz

Model CH: for chemically aggressive drainage water

Design

Ready-to-connect drainage water lifting unit, consisting of:

Collection Tank: Odourtight plastic collection tank. Maximum utility volume 27 liters. One top inlet \varnothing 40 mm. Four lateral inlets \varnothing 50 mm. Discharge \varnothing 40 mm with integrated non-return valve- optional on the left or right site allows flexible connection. Air vent with activated carbon filter.

Pump/Motor: Single-stage stainless steel centrifugal pump with cooling jacket. Motor protection through temperature monitoring. Insulation class F. Protection rating IP 68. Open multi-blade impeller, free passage \varnothing 10 mm. Combination of shaft sealing ring and SIC-mechanical seal. Rotor shaft and motor housing from high quality stainless steel.

Pump Operation Control: Pneumatic level control / float switch. Switching heights: On 200 mm, Off 100 mm. Special float switch to reduce switching height see accessories.

Scope of supply

Collecting tank with pump - fully assembled- hose connection, elastic connection piece, 2x Inlet \varnothing 50-63, 1x Discharge \varnothing 40-45, non-return valve in the pressure outlet. Activated carbon filter in the ventilation with overflow connection. 5 m of connection cable with mains plug.

Installation example

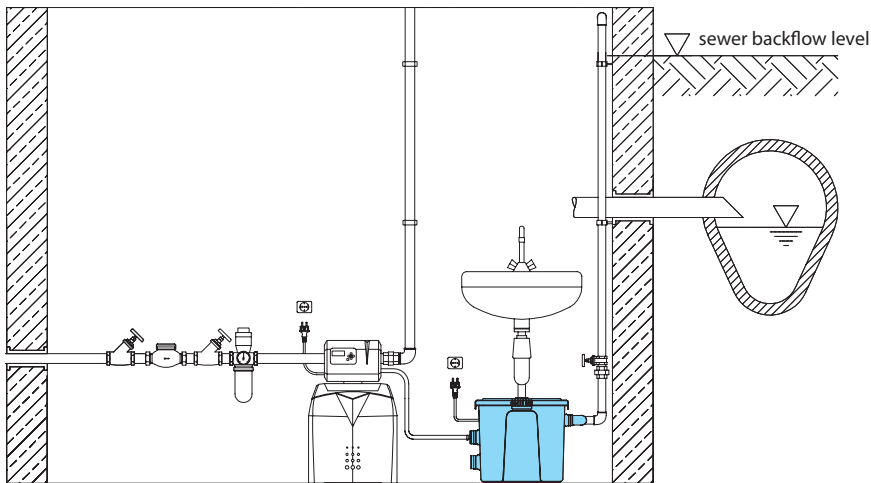

Type	Part no.
San.iQ plus – CH140WA	9804171

Accessories

Description	Part no.
Alarm unit AL3 with level sensor for tanks	1586146
ALWS alarm unit with level sensor for tanks and washing machine off-switch	1586213
Special float switch to reduce switching height for CH140/CH150 (CH140: On ap. 120 mm Off ap. 50 mm) (CH150: On ap. 130 mm Off ap. 60 mm)	7300693.01
Accessories-Kit:	
Inlet San.iQ plus	8609031

Dimensions (all dimensions in mm)

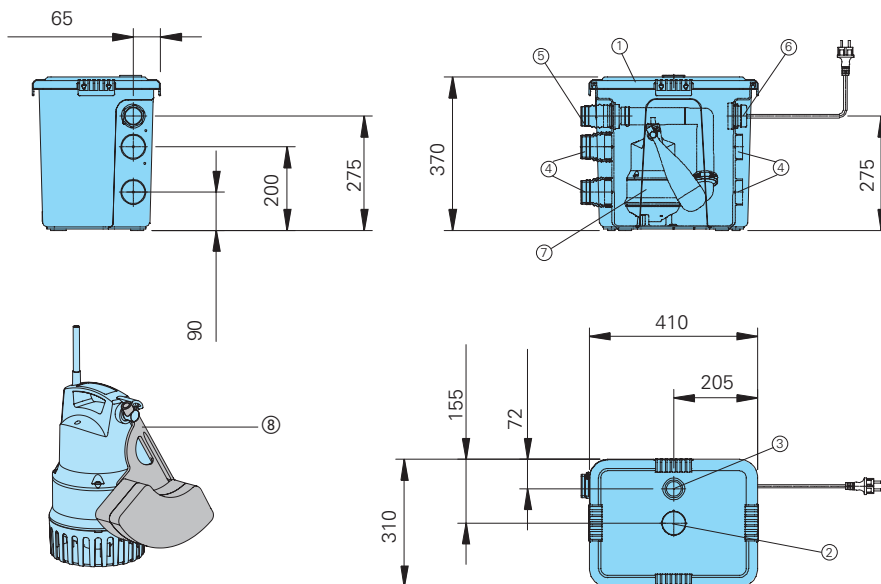

- ① Collecting Tank with cover and seal
- ② Air vent with activated carbon filter
- ③ Inlet Ø 40
- ④ Inlet Ø 50
- ⑤ Discharge Ø 40 with integrated non-return valve
- ⑥ Cable entry for connecting cable with mains plug
- ⑦ Pump with float switch
- ⑧ Pump with float switch to reduce switching height (On ca.120 mm Off ca. 50 mm)

Materials CH140 WA

Collection tank	ABS
Installation kit	Plastic
Pump housing	glass fibre reinforced plastic
Motor housing	highly resistant stainless steel
Impeller	glass fibre reinforced plastic
Motor shaft	highly resistant stainless steel
Screws	Stainless steel
Elastomers	NBR



We reserve the right to alter our specifications without notice!