

Technical Specification

883454\_6.0

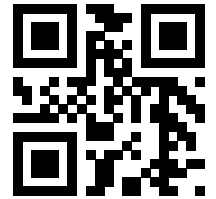
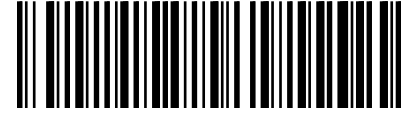

# Flygt 3171

50 HZ



---

# Table of Contents

<b>1 F-pump, Standard Motor</b> .....	<b>2</b>
1.1 Product description.....	2
1.2 Motor rating and performance curves.....	4
<b>2 F-pump, Premium Efficiency Motor (IE3)</b> .....	<b>8</b>
2.1 Product description.....	8
2.2 Motor rating and performance curves.....	10
<b>3 N-pump, Standard Motor</b> .....	<b>14</b>
3.1 Product description.....	14
3.2 Motor rating and performance curves 3171.181/.091/.185/.095.....	17
3.3 Motor rating and performance curves 3171.660/.670.....	20
<b>4 N-pump, Premium Efficiency Motor (IE3)</b> .....	<b>22</b>
4.1 Product description.....	22
4.2 Motor rating and performance curves 3171.800/.810/.820/.830.....	25
4.3 Motor rating and performance curves 3171.860/.870.....	28
<b>5 Dimensions and Weight, Standard Motor</b> .....	<b>30</b>
5.1 Drawings.....	30
<b>6 Dimensions and Weight, Premium Efficiency Motor (IE3)</b> .....	<b>37</b>
6.1 Drawings.....	37

# 1 F-pump, Standard Motor



## 1.1 Product description



### Usage

A submersible chopper pump for liquid manure, fish waste, or heavily contaminated sewage and sludge. The N-hydraulic is fitted with a cutting insert ring. Both impeller and insert ring are manufactured in Hard-Iron™.

### Denomination

Type	Non-explosion proof version	Explosion proof version	Pressure class	Installation types
Hard-Iron™ Chopper	3171.350	3171.390	MT – Medium head HT – High head SH – Super head	P, S, T, Z

The pump can be used in the following installations:

- P Semipermanent, wet well arrangement with the pump installed on two guide bars. The connection to the discharge is automatic.
- S Portable semipermanent, wet well arrangement with hose coupling or flange for connection to the discharge pipeline.
- T Vertical permanent, dry well arrangement with flange connection to the suction and discharge piping.
- Z Horizontal permanent, dry well arrangement with flange connection to the suction and discharge piping.

### Application limits

Feature	Description
Liquid temperature	Maximum 40°C (104°F)
Liquid temperature, warm water version	Maximum 70°C (158°F)
Depth of immersion	Maximum 20 m (65 ft)
pH of the pumped liquid	5.5 - 14
Liquid density	Maximum 1100 kg/m <sup>3</sup>

## Motor data

Feature	Description
Motor type	Squirrel-cage induction motor
Frequency	50 Hz
Power supply	3-phase
Starting method	<ul style="list-style-type: none"> <li>• Direct on-line</li> <li>• Star-delta</li> <li>• Variable Frequency Drive (VFD)</li> </ul>
Number of starts per hour	Maximum 30
Code compliance	IEC 60034-1
Voltage variation	<ul style="list-style-type: none"> <li>• Continuously running: Maximum <math>\pm 5\%</math></li> <li>• Intermittent running: Maximum <math>\pm 10\%</math></li> </ul>
Voltage imbalance between phases	Maximum 2%
Stator insulation class	H (180°C, 356°F)

## Cables

Application	Type
Direct-on-line start or Y/D start with two cables	Flygt SUBCAB® - a heavy duty 4 cores motor power cable with two twisted pair screened control cores. Conductor insulation rating of 90°C, which allows for increased current. Superior mechanical strength and high abrasion and tear resistant. Chemical resistant within pH 3-10 and ozone, oil, and flame resistant. Used up to 70°C water temperature. Cables < 10 mm <sup>2</sup> with unscreened control cores.
Y/D start	Flygt SUBCAB® - a heavy duty 7 cores motor power cable with two twisted pair screened control cores. Conductor insulation rating of 90°C, which allows for increased current. Superior mechanical strength and high abrasion and tear resistant. Chemical resistant within pH 3-10 and ozone, oil, and flame resistant. Used up to 70°C water temperature. Cables < 7G6 mm <sup>2</sup> with unscreened control cores.
Variable Frequency drive	Screened Flygt SUBCAB® - a heavy duty 4 screened cores motor power cable with four twisted pair screened control cores. Conductor insulation rating of 90°C, which allows for increased current. Superior mechanical strength and high abrasion and tear resistant. Chemical resistant within pH 3-10 and ozone, oil, and flame resistant. Used up to 70°C water temperature.

## Monitoring equipment

- Thermal contacts opening temperature 140°C (284°F)
- Leakage sensor in the inspection chamber (FLS10)

## Materials

Table 1: Major parts except mechanical seals

Denomination	Material	ASTM	EN
Major castings	Cast iron, gray	35B	GJL-250
Pump housing	Cast iron, gray	35B	GJL-250
Impeller	Cast iron, Hard-Iron™	A 532 IIIA	GJN-HB555(XCR23)

Denomination	Material	ASTM	EN
Insert ring	Cast iron, Hard-Iron™	A 532 IIIA	GJN-HB555(XCR23)
Cooling jacket, inner	Steel	A572 Grade 60	1.0045, 1.0553, ...
Cooling jacket, outer, alternative 1	Steel	GR65	S235JRG2
Cooling jacket, outer, alternative 2	Stainless steel	AISI 316L	1.4404, 1.4432, ...
Lifting handle	Stainless steel	AISI 316L	1.4404, 1.4432, ...
Shaft	Stainless steel	AISI 431	1.4057+QT800
Screws and nuts	Stainless steel, A4	AISI 316L, 316, 316Ti	1.4401, 1.4404, ...
O-rings, alternative 1	Nitrile rubber (NBR) 70° IRH	-	-
O-rings, alternative 2	Fluorinated rubber (FPM) 70° IRH	-	-
Glycol	Heat transfer fluid based on monopropylene glycol.	-	-

Table 2: Mechanical seals

Alternative	Inner seal	Outer seal
1	Corrosion resistant cemented carbide (WCCR)/ Corrosion resistant cemented carbide (WCCR)	Corrosion resistant cemented carbide (WCCR)/ Corrosion resistant cemented carbide (WCCR)
2	Corrosion resistant cemented carbide (WCCR)/ Corrosion resistant cemented carbide (WCCR)	Silicon carbide (RSiC)/ Silicon carbide (RSiC)

### Surface treatment

Priming	Finish
Painted with a primer, see internal standard M0700.00.0002	Navy gray color NCS 5804-B07G. Two-component high-solid top coating, see internal standard M0700.00.0004 for standard painting and M0700.00.0008 for special painting.

### Options

- Warm liquid version (non-explosion proof versions)
- Sensors: Thermistor, FLS, Pt100, VIS 10
- Surface treatment (Epoxy)
- Zinc anodes
- Other cables

### Accessories

Discharge connections, adapters, hose connections, and other mechanical accessories  
Electrical accessories such as pump controller, control panels, starters, monitoring relays, cables

## 1.2 Motor rating and performance curves

These are examples of motor rating and curves. For more information, please contact your local sales and service representative.

Star-delta starting current is 1/3 of Direct on-line starting current.

MT

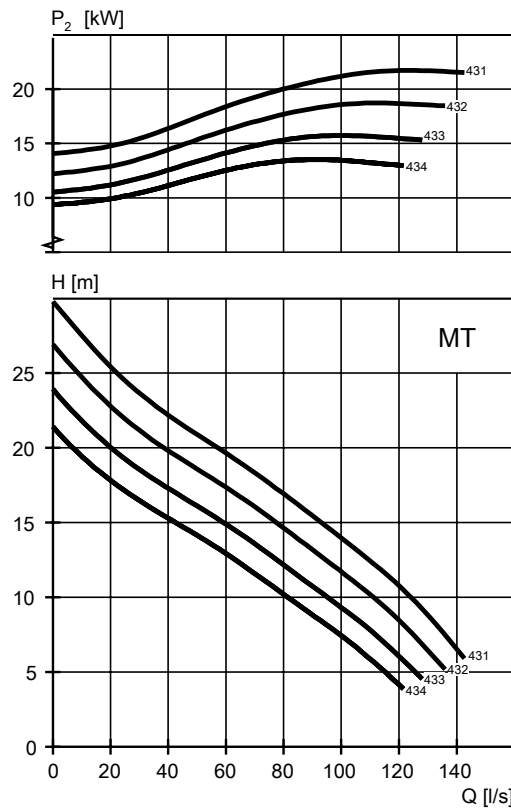

WS005115C

Table 3: 400 V, 50 Hz, 3-phase

Rated power, kW	Rated power, hp	Curve/ Impeller No	Revolutions per minute, rpm	Rated current, A	Starting current, A	Power factor, $\cos \varphi$	Installation
15	20	434	1460	29	177	0.87	P,S,T,Z
18.5	25	433	1460	36	223	0.84	P,S,T,Z
18.5	25	434	1460	36	223	0.84	P,S,T,Z
22	30	431	1460	41	248	0.88	P,S,T,Z
22	30	432	1460	41	248	0.88	P,S,T,Z
22	30	433	1460	41	248	0.88	P,S,T,Z
22	30	434	1460	41	248	0.88	P,S,T,Z

HT

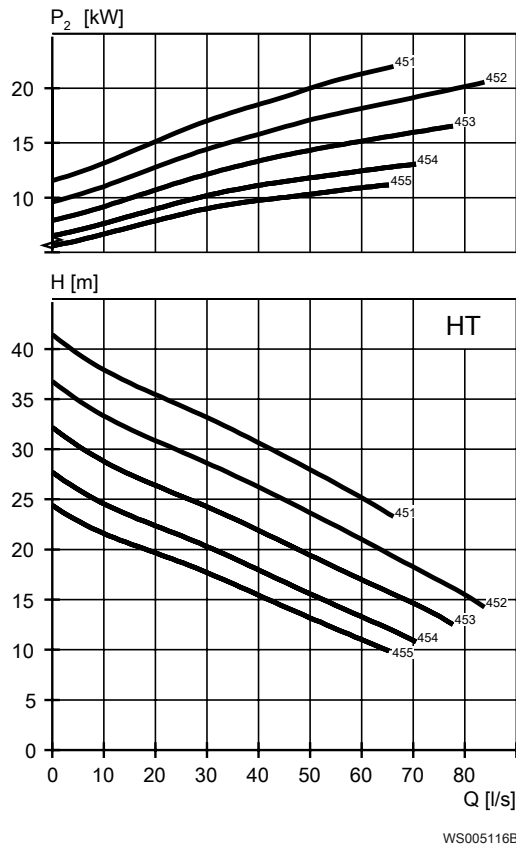

Table 4: 400 V, 50 Hz, 3-phase

Rated power, kW	Rated power, hp	Curve/ Impeller No	Revolutions per minute, rpm	Rated current, A	Starting current, A	Power factor, cos φ	Installation
15	20	454	1460	29	177	0.87	P,S,T,Z
15	20	455	1460	29	177	0.87	P,S,T,Z
18.5	25	453	1460	36	223	0.84	P,S,T,Z
18.5	25	454	1460	36	223	0.84	P,S,T,Z
18.5	25	455	1460	36	223	0.84	P,S,T,Z
22	30	451	1460	41	248	0.88	P,S,T,Z
22	30	452	1460	41	248	0.88	P,S,T,Z
22	30	453	1460	41	248	0.88	P,S,T,Z
22	30	454	1460	41	248	0.88	P,S,T,Z
22	30	455	1460	41	248	0.88	P,S,T,Z



SH

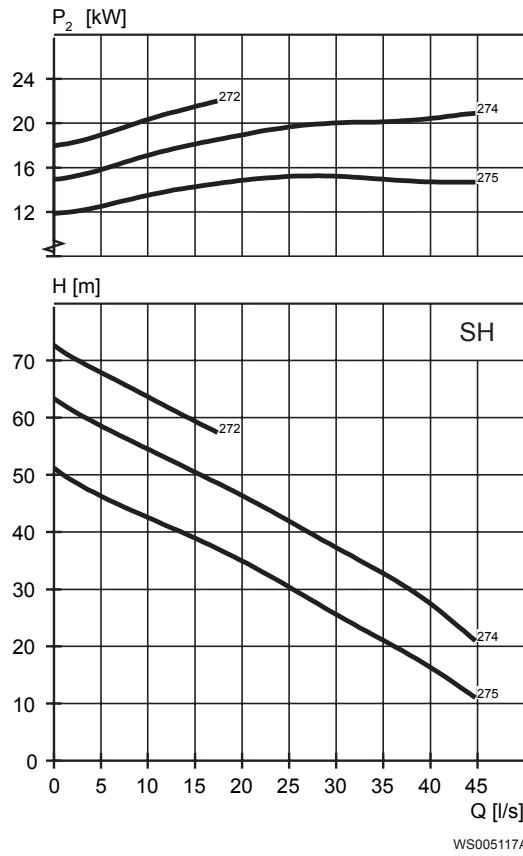

Table 5: 400 V, 50 Hz, 3-phase

Rated power, kW	Rated power, hp	Curve/ Impeller No	Revolutions per minute, rpm	Rated current, A	Starting current, A	Power factor, $\cos \varphi$	Installation
22	30	272	2925	38	269	0.93	P,S,T,Z
22	30	274	2925	38	269	0.93	P,S,T,Z
22	30	275	2925	38	269	0.93	P,S,T,Z

# 2 F-pump, Premium Efficiency Motor (IE3)



## 2.1 Product description



### Usage

A submersible chopper pump for liquid manure, fish waste, or heavily contaminated sewage and sludge. The N-hydraulic is fitted with a cutting insert ring. Both impeller and insert ring are manufactured in Hard-Iron™.

### Denomination

Type	Non-explosion proof version	Explosion proof version	Pressure class	Installation types
Hard-Iron™ Chopper	3171.840	3171.850	MT – Medium head HT – High head SH – Super head	P, S, T, Z

The pump can be used in the following installations:

- P Semipermanent, wet well arrangement with the pump installed on two guide bars. The connection to the discharge is automatic.
- S Portable semipermanent, wet well arrangement with hose coupling or flange for connection to the discharge pipeline.
- T Vertical permanent, dry well arrangement with flange connection to the suction and discharge piping.
- Z Horizontal permanent, dry well arrangement with flange connection to the suction and discharge piping.

### Application limits

Feature	Description
Liquid temperature	Maximum 40°C (104°F)
Depth of immersion	Maximum 20 m (65 ft)
pH of the pumped liquid	5.5 - 14
Liquid density	Maximum 1100 kg/m <sup>3</sup>

## Motor data



Feature	Description
Motor type	Squirrel-cage induction motor
Frequency	50 Hz
Power supply	3-phase
Starting method	<ul style="list-style-type: none"> <li>• Direct on-line</li> <li>• Star-delta</li> <li>• Variable Frequency Drive (VFD)</li> </ul>
Number of starts per hour	Maximum 30
Code compliance	IEC 60034-1
Voltage variation	<ul style="list-style-type: none"> <li>• Continuously running: Maximum <math>\pm 5\%</math></li> <li>• Intermittent running: Maximum <math>\pm 10\%</math></li> </ul>
Voltage imbalance between phases	Maximum 2%
Stator insulation class	H (180°C, 356°F)

## Cables

Application	Type
Direct-on-line start or Y/D start with two cables	Flygt SUBCAB® - a heavy duty 4 cores motor power cable with two twisted pair screened control cores. Conductor insulation rating of 90°C, which allows for increased current. Superior mechanical strength and high abrasion and tear resistant. Chemical resistant within pH 3-10 and ozone, oil, and flame resistant. Used up to 70°C water temperature. Cables < 10 mm <sup>2</sup> with unscreened control cores.
Y/D start	Flygt SUBCAB® - a heavy duty 7 cores motor power cable with two twisted pair screened control cores. Conductor insulation rating of 90°C, which allows for increased current. Superior mechanical strength and high abrasion and tear resistant. Chemical resistant within pH 3-10 and ozone, oil, and flame resistant. Used up to 70°C water temperature. Cables < 7G6 mm <sup>2</sup> with unscreened control cores.
Variable Frequency drive	Screened Flygt SUBCAB® - a heavy duty 4 screened cores motor power cable with four twisted pair screened control cores. Conductor insulation rating of 90°C, which allows for increased current. Superior mechanical strength and high abrasion and tear resistant. Chemical resistant within pH 3-10 and ozone, oil, and flame resistant. Used up to 70°C water temperature.

## Monitoring equipment

- Thermal contacts opening temperature 140°C (284°F)
- Leakage sensor in the inspection chamber (FLS10)

## Materials

Table 6: Major parts except mechanical seals

Denomination	Material	ASTM	EN
Major castings	Cast iron, gray	35B	GJL-250
Pump housing	Cast iron, gray	35B	GJL-250
Impeller	Cast iron, Hard-Iron™	A 532 IIIA	GJN-HB555(XCR23)



Denomination	Material	ASTM	EN
Insert ring	Cast iron, Hard-Iron™	A 532 IIIA	GJN-HB555(XCR23)
Cooling jacket, inner	Steel	A572 Grade 60	1.0045, 1.0553, ...
Cooling jacket, outer	Stainless steel	AISI 316L	1.4404, 1.4432, ...
Lifting handle	Stainless steel	AISI 316L	1.4404, 1.4432, ...
Shaft	Stainless steel	AISI 431	1.4057+QT800
Screws and nuts	Stainless steel, A4	AISI 316L, 316, 316Ti	1.4401, 1.4404, ...
O-rings, alternative 1	Nitrile rubber (NBR) 70° IRH	-	-
O-rings, alternative 2	Fluorinated rubber (FPM) 70° IRH	-	-
Glycol	Heat transfer fluid based on monopropylene glycol.	-	-

Table 7: Mechanical seals

Alternative	Inner seal	Outer seal
1	Corrosion resistant cemented carbide (WCCR)/ Corrosion resistant cemented carbide (WCCR)	Corrosion resistant cemented carbide (WCCR)/ Corrosion resistant cemented carbide (WCCR)
2	Corrosion resistant cemented carbide (WCCR)/ Corrosion resistant cemented carbide (WCCR)	Silicon carbide (RSiC)/ Silicon carbide (RSiC)

### Surface treatment

Priming	Finish
Painted with a primer, see internal standard M0700.00.0002	Navy gray color NCS 5804-B07G. Two-component high-solid top coating, see internal standard M0700.00.0004 for standard painting and M0700.00.0008 for special painting.

### Options

- Sensors: Thermistor, FLS, Pt100, VIS 10
- Surface treatment (Epoxy)
- Zinc anodes
- Other cables

### Accessories

Discharge connections, adapters, hose connections, and other mechanical accessories  
Electrical accessories such as pump controller, control panels, starters, monitoring relays, cables

## 2.2 Motor rating and performance curves

These are examples of motor rating and curves. For more information, please contact your local sales and service representative.

Star-delta starting current is 1/3 of Direct on-line starting current.

MT

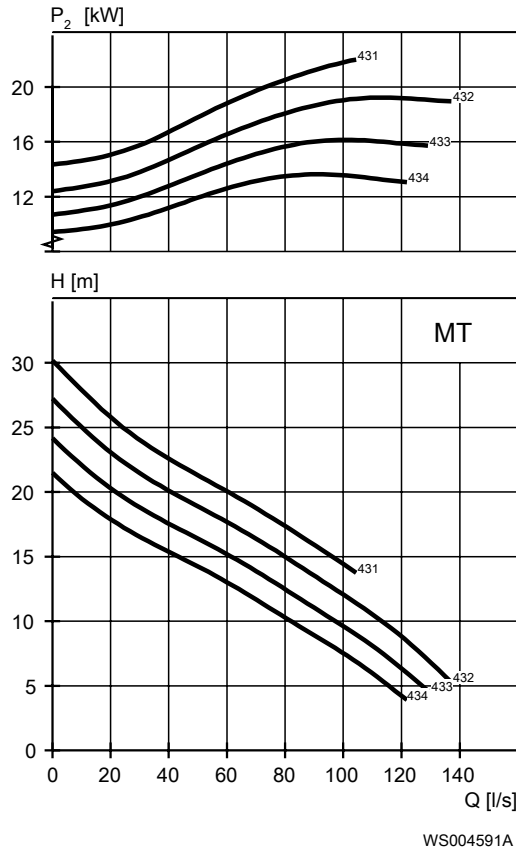

Table 8: 400 V, 50 Hz, 3-phase

Rated power, kW	Rated power, hp	Curve/ Impeller No	Revolutions per minute, rpm	Rated current, A	Starting current, A	Power factor, cos φ	Installation
15	20	433	1475	26	214	0.89	P,S,T,Z
15	20	434	1475	26	214	0.89	P,S,T,Z
18.5	25	432	1475	32	246	0.9	P,S,T,Z
18.5	25	433	1475	32	246	0.9	P,S,T,Z
18.5	25	434	1475	32	246	0.9	P,S,T,Z
22	30	431	1475	40	295	0.86	P,S,T,Z
22	30	432	1475	40	295	0.86	P,S,T,Z
22	30	433	1475	40	295	0.86	P,S,T,Z
22	30	434	1475	40	295	0.86	P,S,T,Z

HT

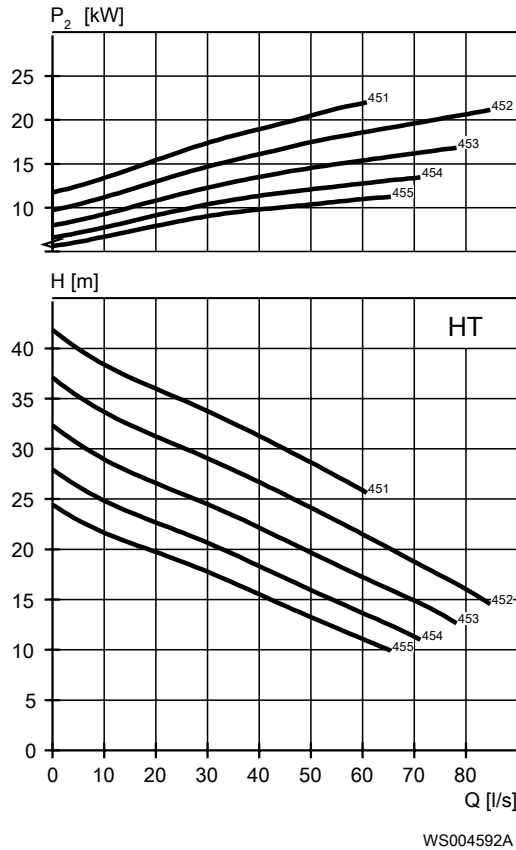
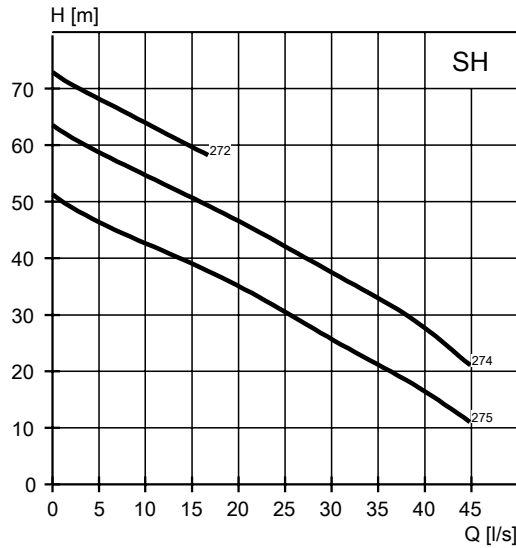
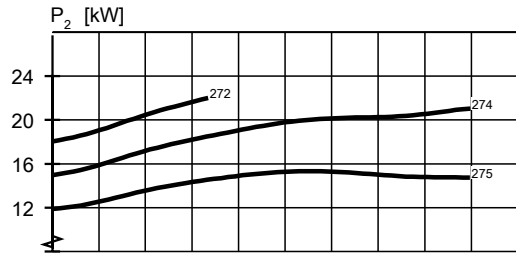

Table 9: 400 V, 50 Hz, 3-phase

Rated power, kW	Rated power, hp	Curve/ Impeller No	Revolutions per minute, rpm	Rated current, A	Starting current, A	Power factor, cos φ	Installation
15	20	453	1475	26	214	0.89	P,S,T,Z
15	20	454	1475	26	214	0.89	P,S,T,Z
15	20	455	1475	26	214	0.89	P,S,T,Z
18.5	25	452	1475	32	246	0.9	P,S,T,Z
18.5	25	453	1475	32	246	0.9	P,S,T,Z
18.5	25	454	1475	32	246	0.9	P,S,T,Z
18.5	25	455	1475	32	246	0.9	P,S,T,Z
22	30	451	1475	40	295	0.86	P,S,T,Z
22	30	452	1475	40	295	0.86	P,S,T,Z
22	30	453	1475	40	295	0.86	P,S,T,Z
22	30	454	1475	40	295	0.86	P,S,T,Z
22	30	455	1475	40	295	0.86	P,S,T,Z

SH



WS004593A

Table 10: 400 V, 50 Hz, 3-phase

Rated power, kW	Rated power, hp	Curve/ Impeller No	Revolutions per minute, rpm	Rated current, A	Starting current, A	Power factor, cos φ	Installation
22	30	272	2935	37	297	0.93	P,S,T,Z
22	30	274	2935	37	297	0.93	P,S,T,Z
22	30	275	2935	37	297	0.93	P,S,T,Z

# 3 N-pump, Standard Motor



## 3.1 Product description



### Usage

A submersible pump for efficient pumping of clean water, surface water, and wastewater containing solids or long-fibred material. The pump is designed for sustained high efficiency. For abrasive media, Hard-Iron™ is required. Stainless steel N-impeller is available as an option.

### Denomination

Type	Non-explosion proof version	Explosion proof version	Pressure class	Installation types
Gray iron	3171.181	3171.091	LT – Low head MT – Medium head HT – High head SH – Super head	P, S, T, Z
Hard-Iron™	3171.185	3171.095	LT – Low head MT – Medium head HT – High head SH – Super head	P, S, T, Z
Stainless steel	3171.660	3171.670	MT – Medium head	P, S

The pump can be used in the following installations:

- P Semipermanent, wet well arrangement with the pump installed on two guide bars. The connection to the discharge is automatic.
- S Portable semipermanent, wet well arrangement with hose coupling or flange for connection to the discharge pipeline.
- T Vertical permanent, dry well arrangement with flange connection to the suction and discharge piping.
- Z Horizontal permanent, dry well arrangement with flange connection to the suction and discharge piping.

### Application limits

Feature	Description
Liquid temperature	Maximum 40°C (104°F)



Feature	Description
Liquid temperature, warm water version	Maximum 70°C (158°F)
Depth of immersion	Maximum 20 m (65 ft)
pH of the pumped liquid	5.5 - 14
Liquid density	Maximum 1100 kg/m <sup>3</sup>

### Motor data

Feature	Description
Motor type	Squirrel-cage induction motor
Frequency	50 Hz
Power supply	3-phase
Starting method	<ul style="list-style-type: none"> <li>• Direct on-line</li> <li>• Star-delta</li> <li>• Variable Frequency Drive (VFD)</li> </ul>
Number of starts per hour	Maximum 30
Code compliance	IEC 60034-1
Voltage variation	<ul style="list-style-type: none"> <li>• Continuously running: Maximum <math>\pm 5\%</math></li> <li>• Intermittent running: Maximum <math>\pm 10\%</math></li> </ul>
Voltage imbalance between phases	Maximum 2%
Stator insulation class	H (180°C, 356°F)

### Cables

Application	Type
Direct-on-line start or Y/D start with two cables	Flygt SUBCAB® - a heavy duty 4 cores motor power cable with two twisted pair screened control cores. Conductor insulation rating of 90°C, which allows for increased current. Superior mechanical strength and high abrasion and tear resistant. Chemical resistant within pH 3-10 and ozone, oil, and flame resistant. Used up to 70°C water temperature. Cables < 10 mm <sup>2</sup> with unscreened control cores.
Y/D start	Flygt SUBCAB® - a heavy duty 7 cores motor power cable with two twisted pair screened control cores. Conductor insulation rating of 90°C, which allows for increased current. Superior mechanical strength and high abrasion and tear resistant. Chemical resistant within pH 3-10 and ozone, oil, and flame resistant. Used up to 70°C water temperature. Cables < 7G6 mm <sup>2</sup> with unscreened control cores.
Variable Frequency drive	Screened Flygt SUBCAB® - a heavy duty 4 screened cores motor power cable with four twisted pair screened control cores. Conductor insulation rating of 90°C, which allows for increased current. Superior mechanical strength and high abrasion and tear resistant. Chemical resistant within pH 3-10 and ozone, oil, and flame resistant. Used up to 70°C water temperature.

### Monitoring equipment

- Thermal contacts opening temperature 140°C (284°F)
- Leakage sensor in the inspection chamber (FLS10)

## Materials

Table 11: Major parts except mechanical seals

Denomination	Material	ASTM	EN
Major castings	Cast iron, gray	35B	GJL-250
Pump housing	Cast iron, gray	35B	GJL-250
Impeller, alternative 1	Cast iron, gray	35B	GJL-250
Impeller, alternative 2	Cast iron, Hard-Iron™	A 532 IIIA	GJN-HB555(XCR23)
Impeller, alternative 3	Stainless steel, Duplex	CD-4MCuN	10283:2010 -1.4474
Insert ring, alternative 1	Cast iron, gray	35B	GJL-250
Insert ring, alternative 2	Cast iron, Hard-Iron™	A 532 IIIA	GJN-HB555(XCR23)
Cooling jacket, inner	Steel	See the standard M0326.2172.00.	
Cooling jacket, outer, alternative 1	Steel	GR65	S235JRG2
Cooling jacket, outer, alternative 2	Stainless steel	AISI 316L	1.4404,1.4432, ...
Lifting handle	Stainless steel	AISI 316L	1.4404,1.4432, ...
Shaft	Stainless steel	AISI 431	1.4057+QT800
Screws and nuts	Stainless steel, A4	AISI 316L, 316, 316Ti	1.4401,1.4404, ...
O-rings, alternative 1	Nitrile rubber (NBR) 70° IRH	-	-
O-rings, alternative 2	Fluorinated rubber (FPM) 70° IRH	-	-
Glycol	Heat transfer fluid based on monopropylene glycol.	-	-

Table 12: Mechanical seals

Alternative	Inner seal	Outer seal
1	Corrosion resistant cemented carbide (WCCR)/ Corrosion resistant cemented carbide (WCCR)	Corrosion resistant cemented carbide (WCCR)/ Corrosion resistant cemented carbide (WCCR)
2	Corrosion resistant cemented carbide (WCCR)/ Corrosion resistant cemented carbide (WCCR)	Silicon carbide (RSiC)/ Silicon carbide (RSiC)

## Surface treatment

Priming	Finish
Painted with a primer, see internal standard M0700.00.0002	Navy gray color NCS 5804-B07G. Two-component high-solid top coating, see internal standard M0700.00.0004 for standard painting and M0700.00.0008 for special painting.

## Options

- Warm liquid version (non-explosion proof versions)
- Sensors: Thermistor, FLS, Pt100, VIS 10
- Surface treatment (Epoxy)
- Zinc anodes
- Other cables

## Accessories

Discharge connections, adapters, hose connections, and other mechanical accessories



Electrical accessories such as pump controller, control panels, starters, monitoring relays, cables

## 3.2 Motor rating and performance curves 3171.181/.091/.185/.095

These are examples of motor rating and curves. For more information, please contact your local sales and service representative.

Star-delta starting current is 1/3 of Direct on-line starting current.

LT

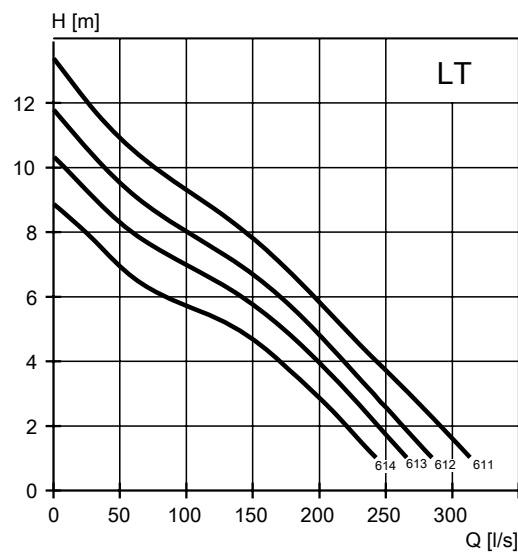
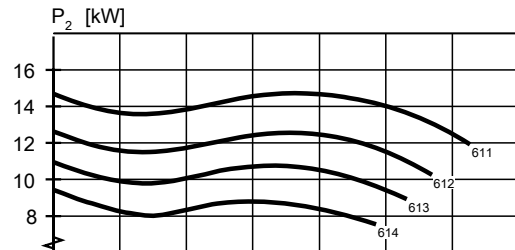

WS005208A

Table 13: 400 V, 50 Hz, 3-phase

Rated power, kW	Rated power, hp	Curve/ Impeller No	Revolutions per minute, rpm	Rated current, A	Starting current, A	Power factor, cos $\phi$	Installation
15	20	611	965	30	167	0.84	P,S,T,Z
15	20	612	965	30	167	0.84	P,S,T,Z
15	20	613	965	30	167	0.84	P,S,T,Z
15	20	614	965	30	167	0.84	P,S,T,Z

MT

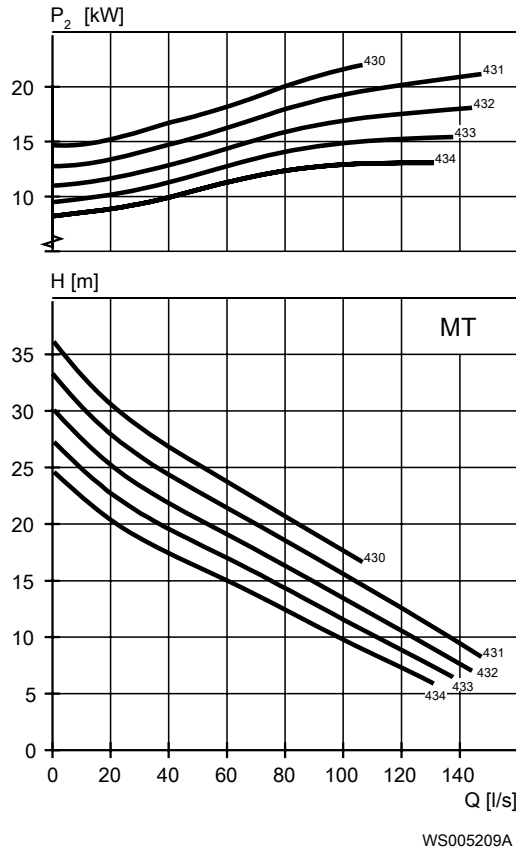

Table 14: 400 V, 50 Hz, 3-phase

Rated power, kW	Rated power, hp	Curve/ Impeller No	Revolutions per minute, rpm	Rated current, A	Starting current, A	Power factor, cos φ	Installation
15	20	433	1460	29	177	0.87	P,S,T,Z
15	20	434	1460	29	177	0.87	P,S,T,Z
18.5	25	432	1460	36	223	0.84	P,S,T,Z
18.5	25	433	1460	36	223	0.84	P,S,T,Z
18.5	25	434	1460	36	223	0.84	P,S,T,Z
22	30	430	1460	41	248	0.88	P,S,T,Z
22	30	431	1460	41	248	0.88	P,S,T,Z
22	30	432	1460	41	248	0.88	P,S,T,Z
22	30	433	1460	41	248	0.88	P,S,T,Z
22	30	434	1460	41	248	0.88	P,S,T,Z

<sup>1</sup> Only applicable for 3171.181 and 3171.091

HT

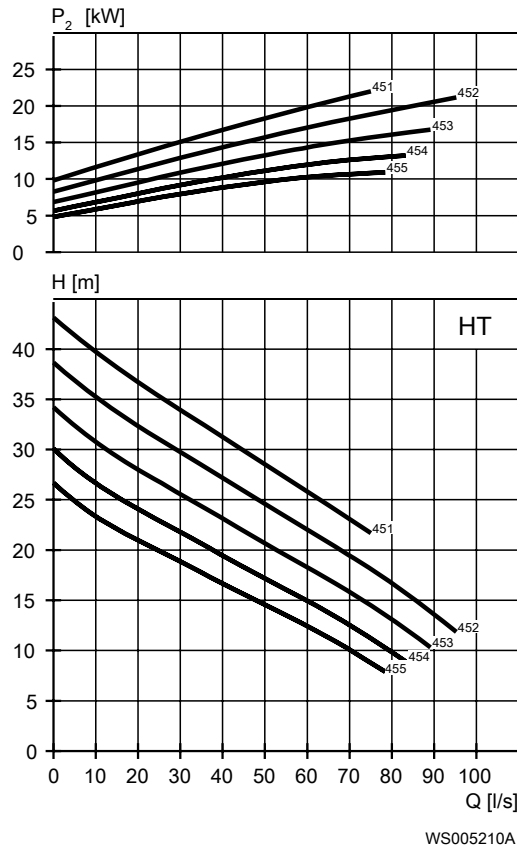

Table 15: 400 V, 50 Hz, 3-phase

Rated power, kW	Rated power, hp	Curve/ Impeller No	Revolutions per minute, rpm	Rated current, A	Starting current, A	Power factor, cos $\phi$	Installation
15	20	451	1460	29	177	0.87	P,S,T,Z
15	20	452	1460	29	177	0.87	P,S,T,Z
15	20	453	1460	29	177	0.87	P,S,T,Z
15	20	454	1460	29	177	0.87	P,S,T,Z
15	20	455	1460	29	177	0.87	P,S,T,Z
18.5	25	451	1460	36	223	0.84	P,S,T,Z
18.5	25	452	1460	36	223	0.84	P,S,T,Z
18.5	25	453	1460	36	223	0.84	P,S,T,Z
18.5	25	454	1460	36	223	0.84	P,S,T,Z
18.5	25	455	1460	36	223	0.84	P,S,T,Z
22	30	451	1460	41	248	0.88	P,S,T,Z
22	30	452	1460	41	248	0.88	P,S,T,Z
22	30	453	1460	41	248	0.88	P,S,T,Z
22	30	454	1460	41	248	0.88	P,S,T,Z
22	30	455	1460	41	248	0.88	P,S,T,Z

SH

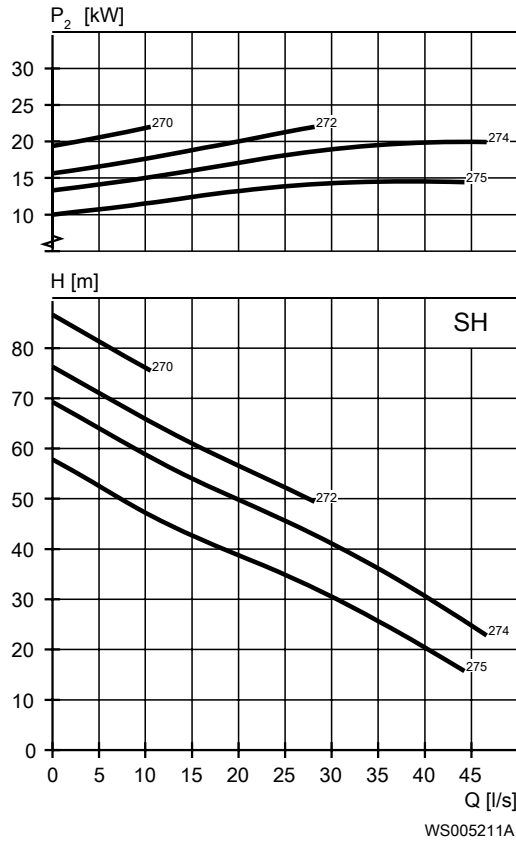

Table 16: 400 V, 50 Hz, 3-phase

Rated power, kW	Rated power, hp	Curve/ Impeller No	Revolutions per minute, rpm	Rated current, A	Starting current, A	Power factor, cos φ	Installation
22	30	270	2925	38	269	0.93	P,S,T,Z
22	30	272	2925	38	269	0.93	P,S,T,Z
22	30	274	2925	38	269	0.93	P,S,T,Z
22	30	275	2925	38	269	0.93	P,S,T,Z

### 3.3 Motor rating and performance curves 3171.660/.670

These are examples of motor rating and curves. For more information, please contact your local sales and service representative.

Star-delta starting current is 1/3 of Direct on-line starting current.

MT

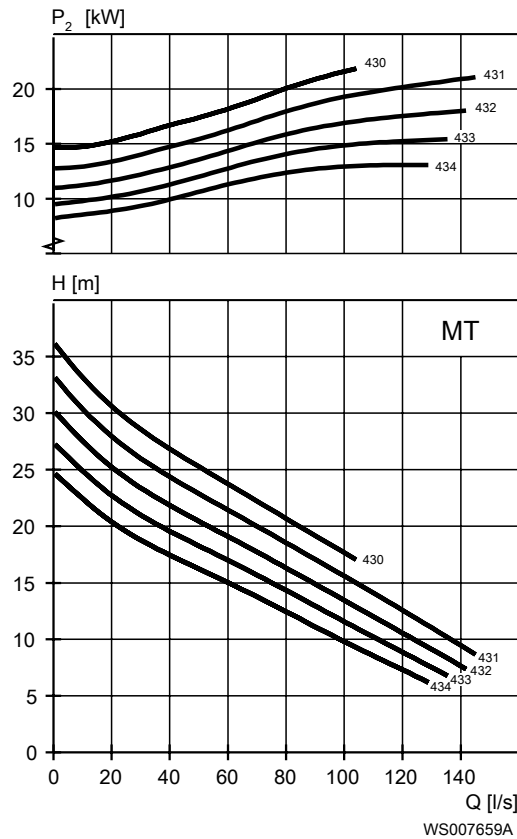

Table 17: 400 V, 50 Hz, 3-phase

Rated power, kW	Rated power, hp	Curve/ Impeller No	Revolutions per minute, rpm	Rated Current, A	Start current, A	Power Factor, $\cos \phi$	Installation
15	20	434	1460	29	177	0.87	P,S
18.5	25	432	1460	36	223	0.86	P,S
18.5	25	433	1460	36	223	0.86	P,S
18.5	25	434	1460	36	223	0.86	P,S
22	30	430	1460	41	251	0.87	P,S
22	30	431	1460	41	251	0.87	P,S
22	30	432	1460	41	251	0.87	P,S
22	30	433	1460	41	251	0.87	P,S
22	30	434	1460	41	251	0.87	P,S

# 4 N-pump, Premium Efficiency Motor (IE3)



## 4.1 Product description



### Usage

A submersible pump for efficient pumping of clean water, surface water, and wastewater containing solids or long-fibered material. The pump is designed for sustained high efficiency. For abrasive media, Hard-Iron™ is required. Stainless steel N-impeller is available as an option.

### Denomination

Type	Non-explosion proof version	Explosion proof version	Pressure class	Installation types
Gray iron	3171.800	3171.810	LT – Low head MT – Medium head HT – High head SH – Super head	P, S, T, Z
Hard-Iron™	3171.820	3171.830	LT – Low head MT – Medium head HT – High head SH – Super head	P, S, T, Z
Stainless steel	3171.860	3171.870	MT – Medium head	P, S

The pump can be used in the following installations:

- P Semipermanent, wet well arrangement with the pump installed on two guide bars. The connection to the discharge is automatic.
- S Portable semipermanent, wet well arrangement with hose coupling or flange for connection to the discharge pipeline.
- T Vertical permanent, dry well arrangement with flange connection to the suction and discharge piping.
- Z Horizontal permanent, dry well arrangement with flange connection to the suction and discharge piping.



### Application limits

Feature	Description
Liquid temperature	Maximum 40°C (104°F)
Depth of immersion	Maximum 20 m (65 ft)
pH of the pumped liquid	5.5 - 14
Liquid density	Maximum 1100 kg/m <sup>3</sup>

### Motor data

Feature	Description
Motor type	Squirrel-cage induction motor
Frequency	50 Hz
Power supply	3-phase
Starting method	<ul style="list-style-type: none"> <li>• Direct on-line</li> <li>• Star-delta</li> <li>• Variable Frequency Drive (VFD)</li> </ul>
Number of starts per hour	Maximum 30
Code compliance	IEC 60034-1
Voltage variation	<ul style="list-style-type: none"> <li>• Continuously running: Maximum ±5%</li> <li>• Intermittent running: Maximum ±10%</li> </ul>
Voltage imbalance between phases	Maximum 2%
Stator insulation class	H (180°C, 356°F)

### Cables

Application	Type
Direct-on-line start or Y/D start with two cables	Flygt SUBCAB® - a heavy duty 4 cores motor power cable with two twisted pair screened control cores. Conductor insulation rating of 90°C, which allows for increased current. Superior mechanical strength and high abrasion and tear resistant. Chemical resistant within pH 3-10 and ozone, oil, and flame resistant. Used up to 70°C water temperature. Cables < 10 mm <sup>2</sup> with unscreened control cores.
Y/D start	Flygt SUBCAB® - a heavy duty 7 cores motor power cable with two twisted pair screened control cores. Conductor insulation rating of 90°C, which allows for increased current. Superior mechanical strength and high abrasion and tear resistant. Chemical resistant within pH 3-10 and ozone, oil, and flame resistant. Used up to 70°C water temperature. Cables < 7G6 mm <sup>2</sup> with unscreened control cores.
Variable Frequency drive	Screened Flygt SUBCAB® - a heavy duty 4 screened cores motor power cable with four twisted pair screened control cores. Conductor insulation rating of 90°C, which allows for increased current. Superior mechanical strength and high abrasion and tear resistant. Chemical resistant within pH 3-10 and ozone, oil, and flame resistant. Used up to 70°C water temperature.

### Monitoring equipment

- Thermal contacts opening temperature 140°C (284°F)
- Leakage sensor in the inspection chamber (FLS10)

## Materials



Table 18: Major parts except mechanical seals

Denomination	Material	ASTM	EN
Major castings	Cast iron, gray	35B	GJL-250
Pump housing	Cast iron, gray	35B	GJL-250
Impeller, alternative 1	Cast iron, gray	35B	GJL-250
Impeller, alternative 2	Cast iron, Hard-Iron™	A 532 IIIA	GJN-HB555(XCR23)
Impeller, alternative 3	Stainless steel, Duplex	CD-4MCuN	10283:2010 -1.4474
Insert ring, alternative 1	Cast iron, gray	35B	GJL-250
Insert ring, alternative 2	Cast iron, Hard-Iron™	A 532 IIIA	GJN-HB555(XCR23)
Cooling jacket, inner	Steel	A572 Grade 60	1.0045, 1.0553, ...
Cooling jacket, outer	Stainless steel	AISI 316L	1.4404, 1.4432, ...
Lifting handle	Stainless steel	AISI 316L	1.4404, 1.4432, ...
Shaft	Stainless steel	AISI 431	1.4057+QT800
Screws and nuts	Stainless steel, A4	AISI 316L, 316, 316Ti	1.4401, 1.4404, ...
O-rings, alternative 1	Nitrile rubber (NBR) 70° IRH	-	-
O-rings, alternative 2	Fluorinated rubber (FPM) 70° IRH	-	-
Glycol	Heat transfer fluid based on monopropylene glycol.	-	-

Table 19: Mechanical seals

Alternative	Inner seal	Outer seal
1	Corrosion resistant cemented carbide (WCCR)/ Corrosion resistant cemented carbide (WCCR)	Corrosion resistant cemented carbide (WCCR)/ Corrosion resistant cemented carbide (WCCR)
2	Corrosion resistant cemented carbide (WCCR)/ Corrosion resistant cemented carbide (WCCR)	Silicon carbide (RSiC)/ Silicon carbide (RSiC)

## Surface treatment

Priming	Finish
Painted with a primer, see internal standard M0700.00.0002	Navy gray color NCS 5804-B07G. Two-component high-solid top coating, see internal standard M0700.00.0004 for standard painting and M0700.00.0008 for special painting.

## Options

- Sensors: Thermistor, FLS, Pt100, VIS 10
- Surface treatment (Epoxy)
- Zinc anodes
- Other cables

## Accessories

Discharge connections, adapters, hose connections, and other mechanical accessories  
Electrical accessories such as pump controller, control panels, starters, monitoring relays, cables

## 4.2 Motor rating and performance curves 3171.800/.810/.820/.830

These are examples of motor rating and curves. For more information, please contact your local sales and service representative.

Star-delta starting current is 1/3 of Direct on-line starting current.

LT

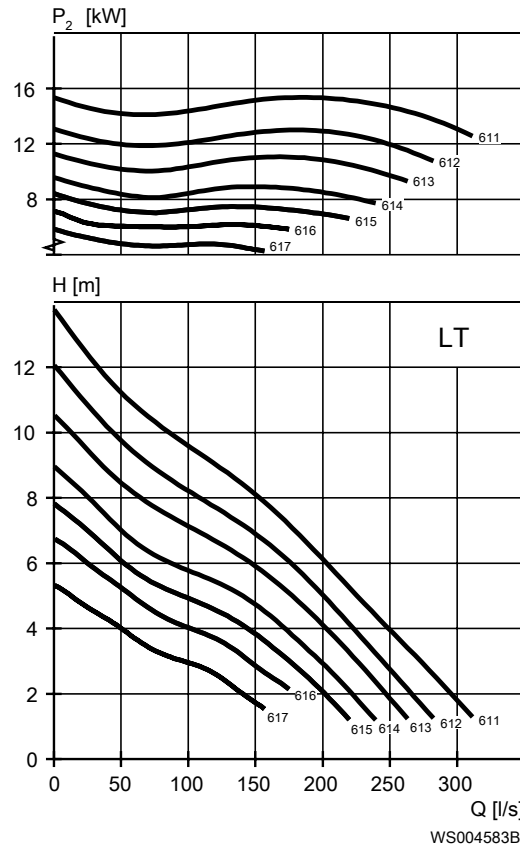
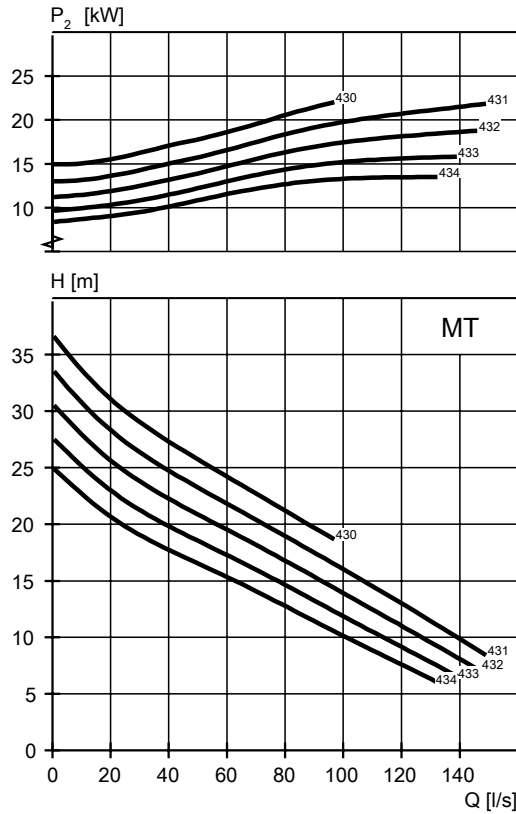

Table 20: 400 V, 50 Hz, 3-phase

Rated power, kW	Rated power, hp	Curve/ Impeller No	Revolutions per minute, rpm	Rated Current, A	Start current, A	Power Factor, cos $\phi$	Installation
10	13.4	614	985	19	151	0.83	P,S,T,Z
10	13.4	615	985	19	151	0.83	P,S,T,Z
10	13.4	616	985	19	151	0.83	P,S,T,Z
10	13.4	617	985	19	151	0.83	P,S,T,Z
15.5	21	611	980	30	201	0.81	P,S,T,Z
15.5	21	612	980	30	201	0.81	P,S,T,Z
15.5	21	613	980	30	201	0.81	P,S,T,Z
15.5	21	614	980	30	201	0.81	P,S,T,Z
15.5	21	615	980	30	201	0.81	P,S,T,Z
15.5	21	616	980	30	201	0.81	P,S,T,Z
15.5	21	617	980	30	201	0.81	P,S,T,Z

MT



WS004584A

Table 21: 400 V, 50 Hz, 3-phase

Rated power, kW	Rated power, hp	Curve/ Impeller No	Revolutions per minute, rpm	Rated current, A	Starting current, A	Power factor, cos φ	Installation
15	20	432	1475	26	214	0.89	P,S,T,Z
15	20	433	1475	26	214	0.89	P,S,T,Z
15	20	434	1475	26	214	0.89	P,S,T,Z
18.5	25	431	1475	32	246	0.9	P,S,T,Z
18.5	25	432	1475	32	246	0.9	P,S,T,Z
18.5	25	433	1475	32	246	0.9	P,S,T,Z
18.5	25	434	1475	32	246	0.9	P,S,T,Z
22	30	430	1475	40	295	0.86	P,S,T,Z
22	30	431	1475	40	295	0.86	P,S,T,Z
22	30	432	1475	40	295	0.86	P,S,T,Z
22	30	433	1475	40	295	0.86	P,S,T,Z
22	30	434	1475	40	295	0.86	P,S,T,Z

<sup>2</sup> Only applicable for 3171.800 and 3171.810

HT

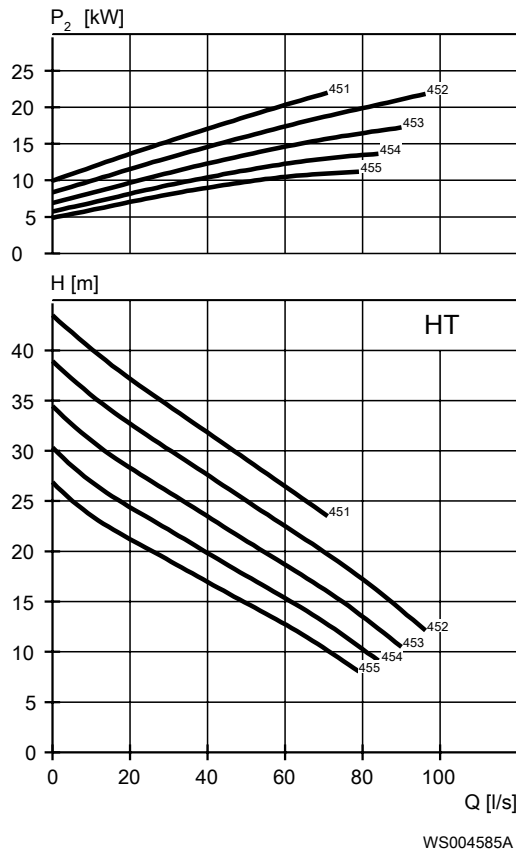

Table 22: 400 V, 50 Hz, 3-phase

Rated power, kW	Rated power, hp	Curve/ Impeller No	Revolutions per minute, rpm	Rated current, A	Starting current, A	Power factor, cos φ	Installation
15	20	451	1475	26	214	0.89	P,S,T,Z
15	20	452	1475	26	214	0.89	P,S,T,Z
15	20	453	1475	26	214	0.89	P,S,T,Z
15	20	454	1475	26	214	0.89	P,S,T,Z
15	20	455	1475	26	214	0.89	P,S,T,Z
18.5	25	451	1475	32	246	0.9	P,S,T,Z
18.5	25	452	1475	32	246	0.9	P,S,T,Z
18.5	25	453	1475	32	246	0.9	P,S,T,Z
18.5	25	454	1475	32	246	0.9	P,S,T,Z
18.5	25	455	1475	32	246	0.9	P,S,T,Z
22	30	451	1475	40	295	0.86	P,S,T,Z
22	30	452	1475	40	295	0.86	P,S,T,Z
22	30	453	1475	40	295	0.86	P,S,T,Z
22	30	454	1475	40	295	0.86	P,S,T,Z
22	30	455	1475	40	295	0.86	P,S,T,Z

SH

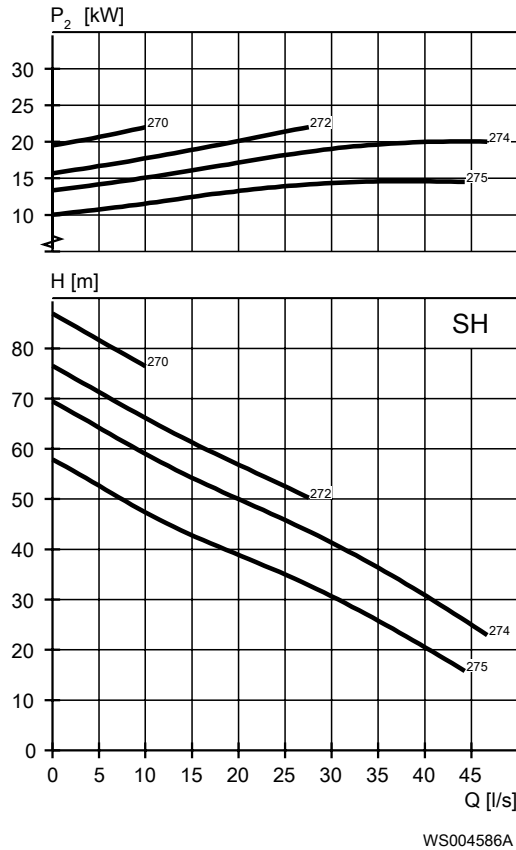

Table 23: 400 V, 50 Hz, 3-phase

Rated power, kW	Rated power, hp	Curve/ Impeller No	Revolutions per minute, rpm	Rated current, A	Starting current, A	Power factor, cos φ	Installation
22	30	270	2935	37	297	0.93	P,S,T,Z
22	30	272	2935	37	297	0.93	P,S,T,Z
22	30	274	2935	37	297	0.93	P,S,T,Z
22	30	275	2935	37	297	0.93	P,S,T,Z

### 4.3 Motor rating and performance curves 3171.860/.870

These are examples of motor rating and curves. For more information, please contact your local sales and service representative.

Star-delta starting current is 1/3 of Direct on-line starting current.

MT

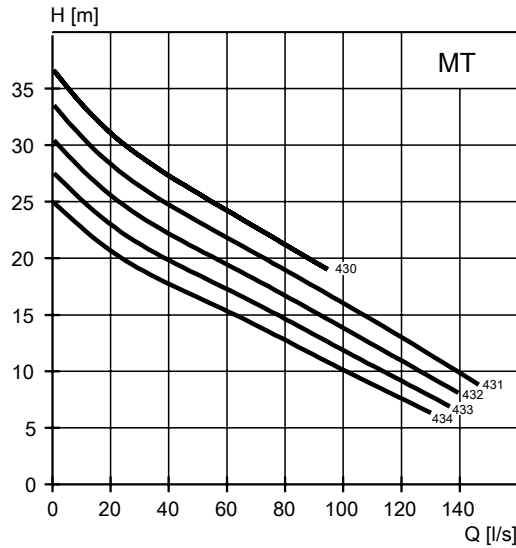
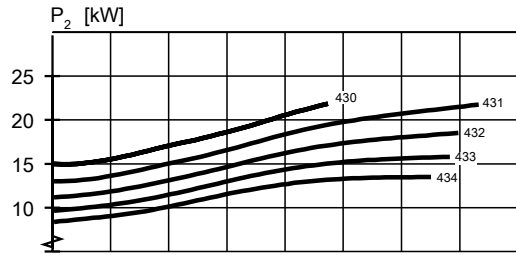

WS007661A

Table 24: 400 V, 50 Hz, 3-phase

Rated power, kW	Rated power, hp	Curve/ Impeller No	Revolutions per minute, rpm	Rated Current, A	Start current, A	Power Factor, cos φ	Installation
15	20	434	1475	26	214	0.89	P,S
18.5	25	432	1475	32	246	0.9	P,S
18.5	25	433	1475	32	246	0.9	P,S
18.5	25	434	1475	32	246	0.9	P,S
22	30	430	1475	40	295	0.86	P,S
22	30	431	1475	40	295	0.86	P,S
22	30	434	1475	40	295	0.86	P,S

# 5 Dimensions and Weight, Standard Motor

## 5.1 Drawings

All drawings are available as Acrobat documents (.pdf) and AutoCad drawings (.dwg). Contact a local sales and service representative for more information.

All dimensions are in mm.

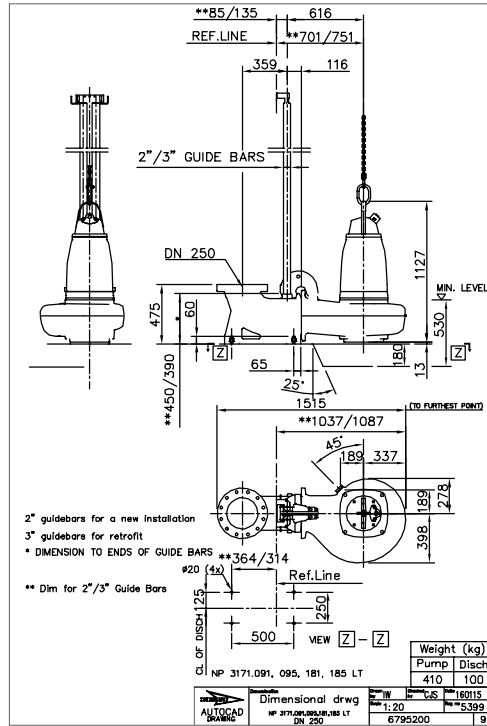

Figure 1: LT, P-installation

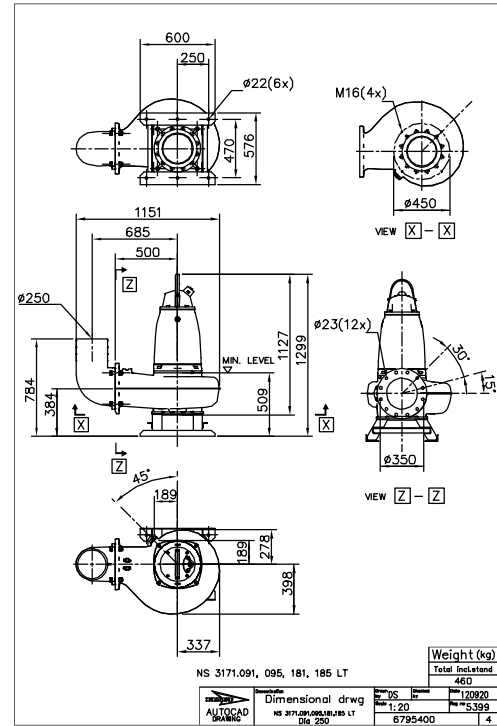

Figure 2: LT, S-installation



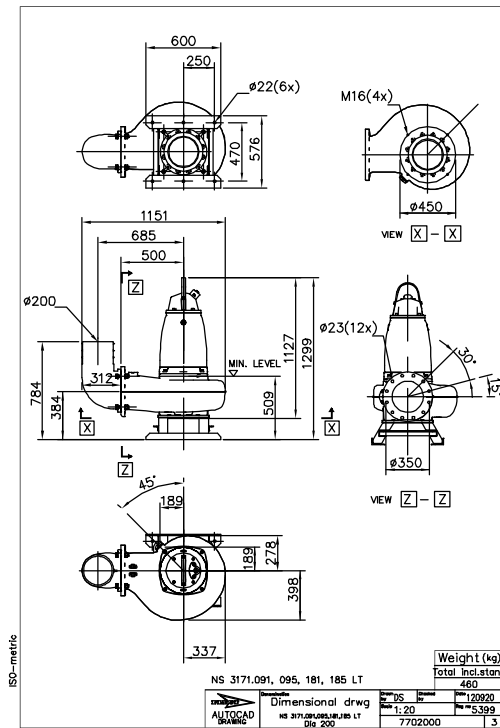

Figure 3: LT, S-installation

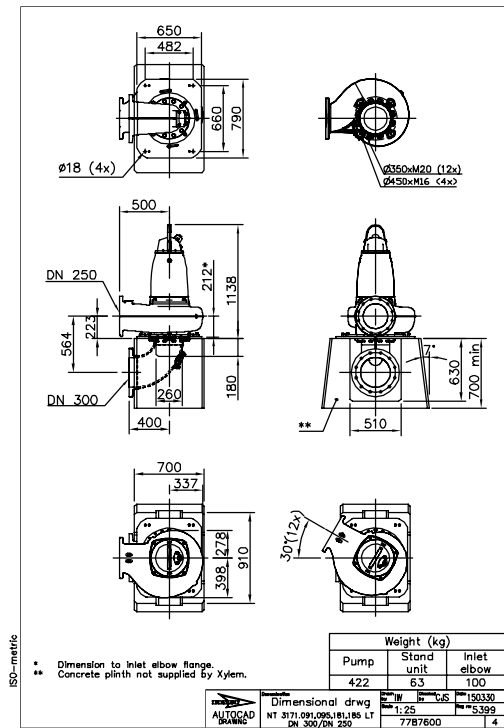

Figure 4: LT, T-installation

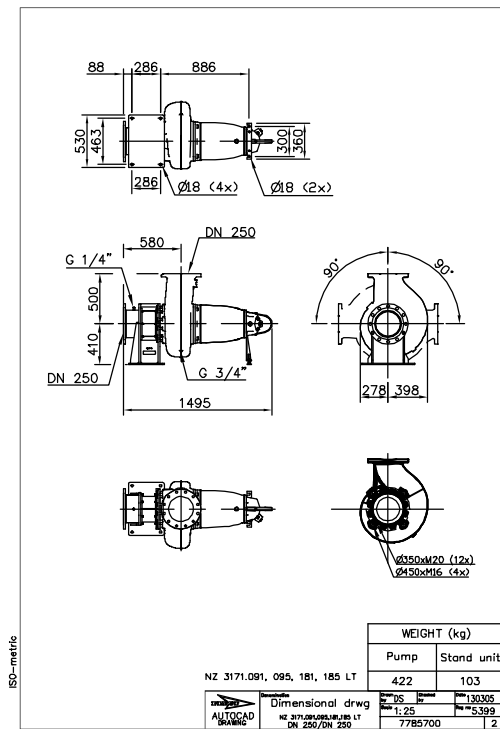

Figure 5: LT, Z-installation

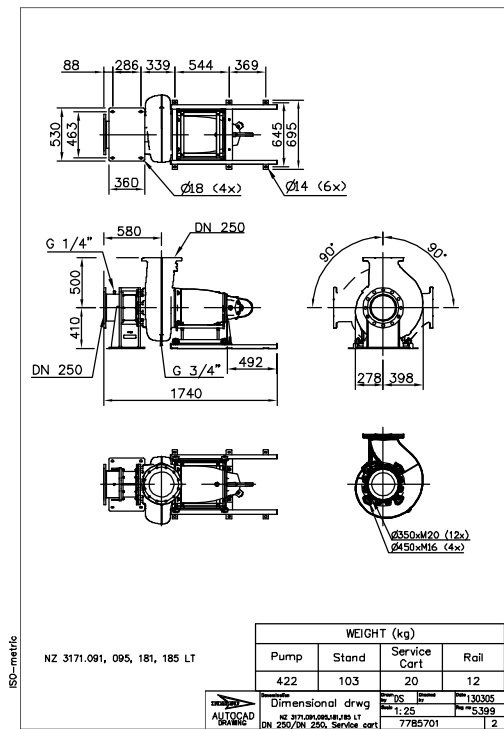

Figure 6: LT, Z-installation

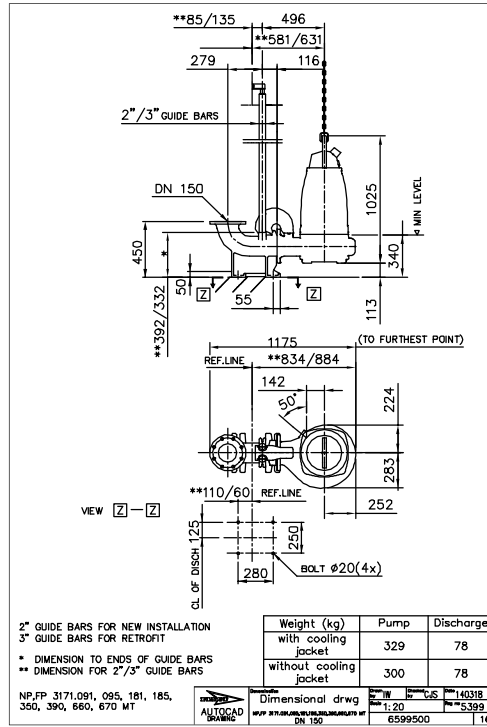

Figure 7: MT, P-installation

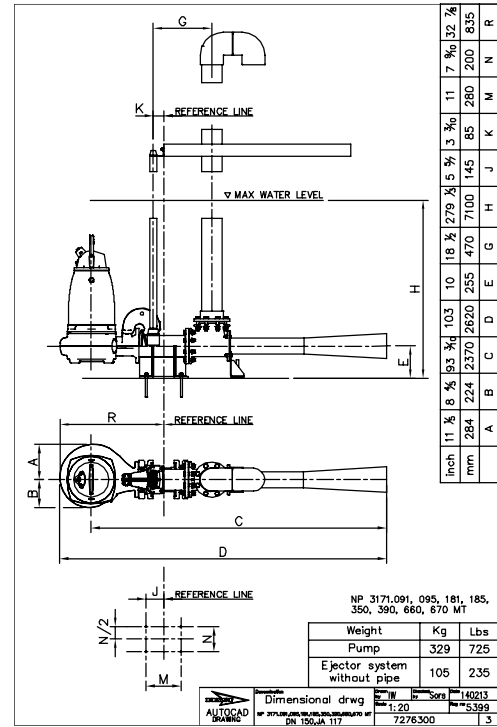

Figure 8: MT, P-installation

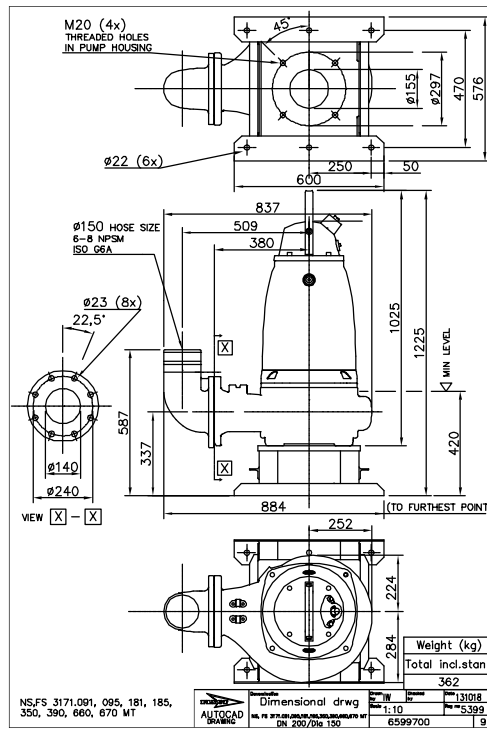

Figure 9: MT, S-installation

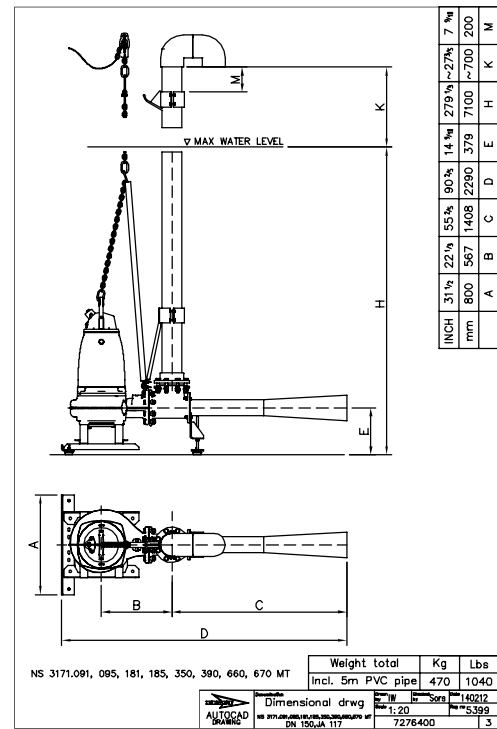

Figure 10: MT, S-installation

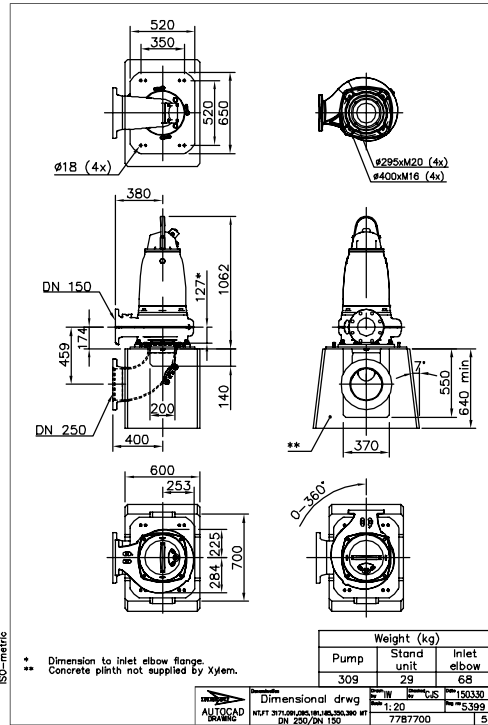

Figure 11: MT, T-installation

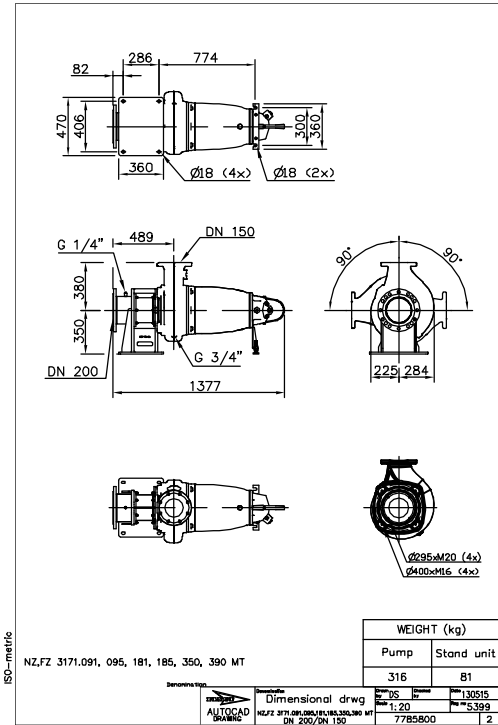

Figure 12: MT, Z-installation

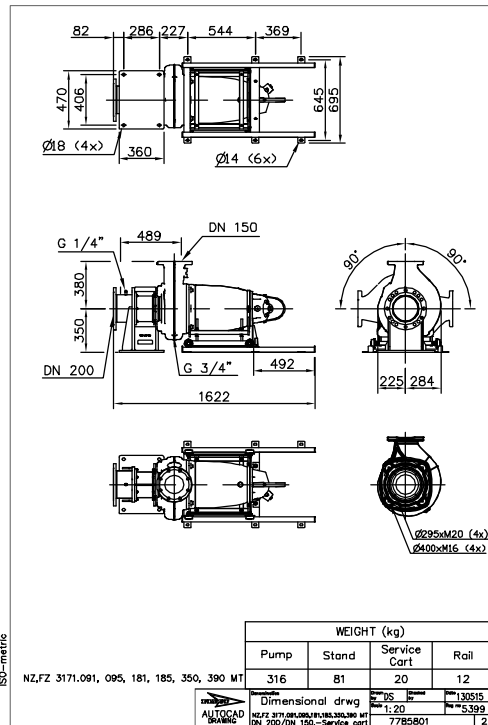

Figure 13: MT, Z-installation

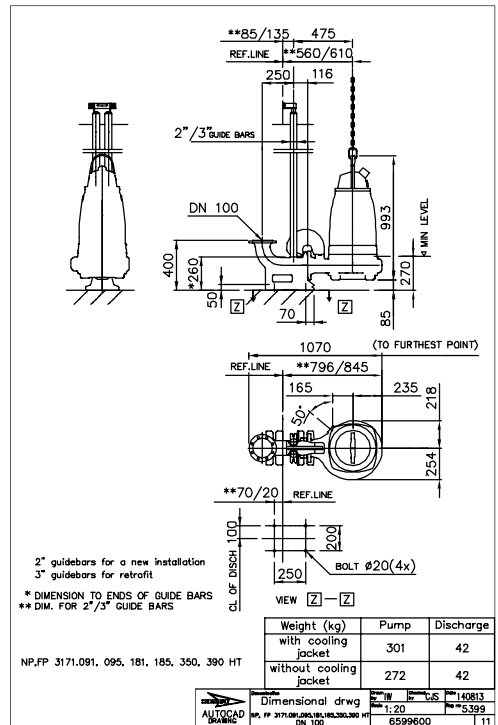

Figure 14: HT, P-installation



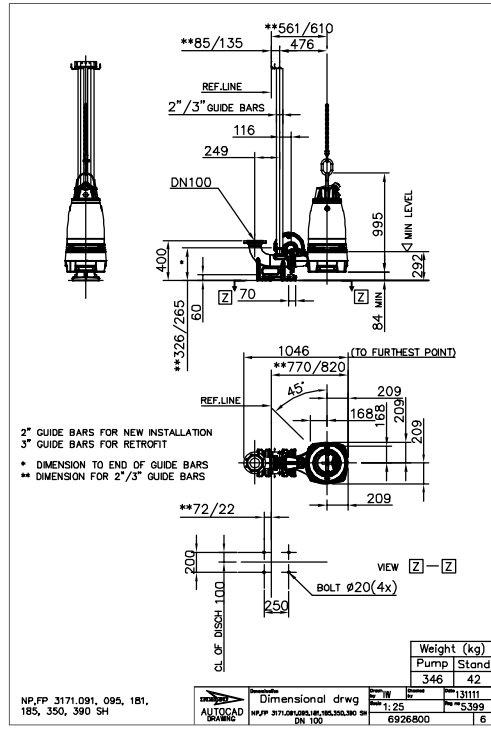

Figure 19: SH, P-installation

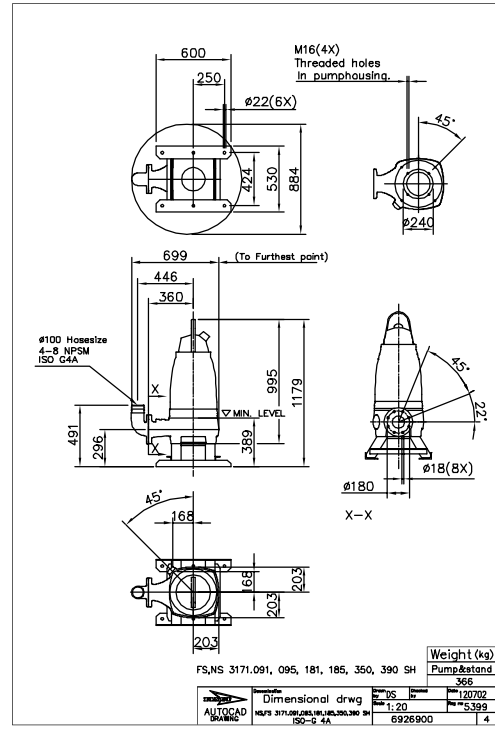

Figure 20: SH, S-installation

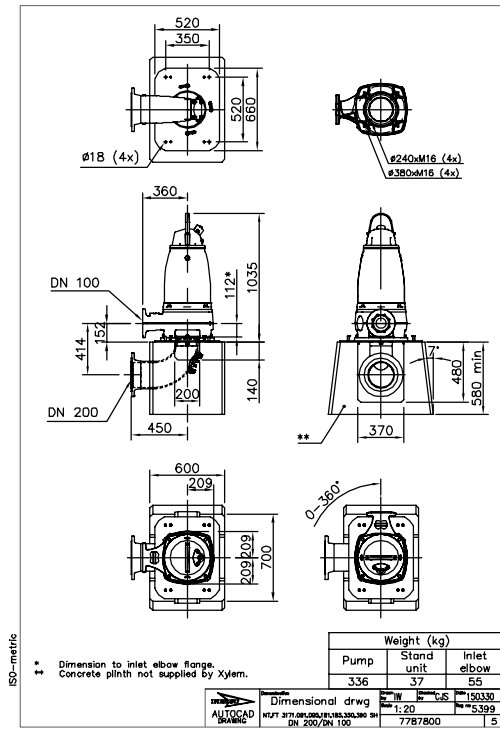

Figure 21: SH, T-installation

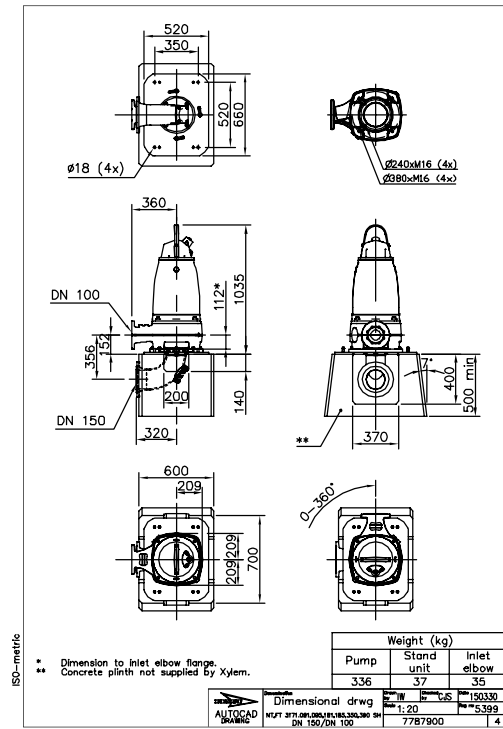

Figure 22: SH, T-installation

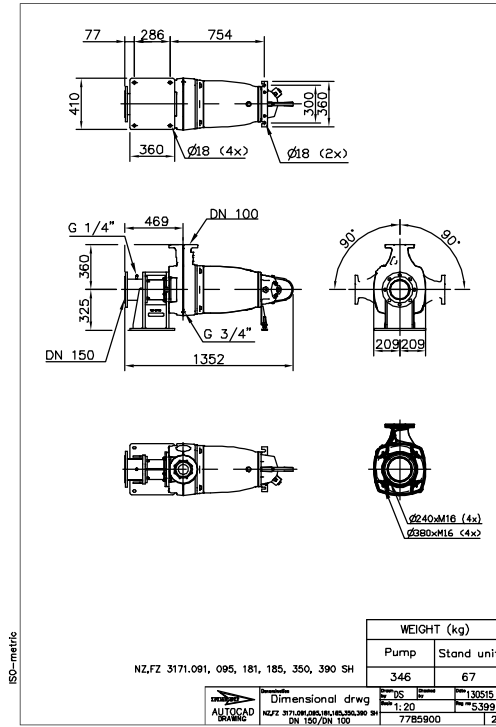

Figure 23: SH, Z-installation

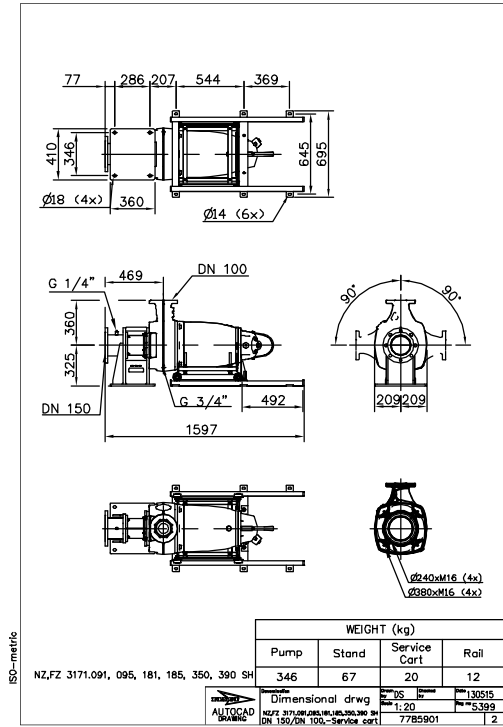

Figure 24: SH, Z-installation

# 6 Dimensions and Weight, Premium Efficiency Motor (IE3)

## 6.1 Drawings

All drawings are available as Acrobat documents (.pdf) and AutoCad drawings (.dwg). Contact a local sales and service representative for more information.

All dimensions are in mm.

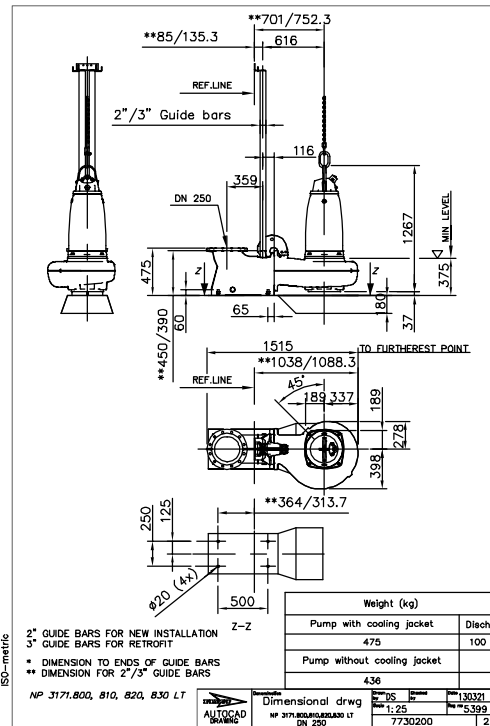

Figure 25: LT, P-installation

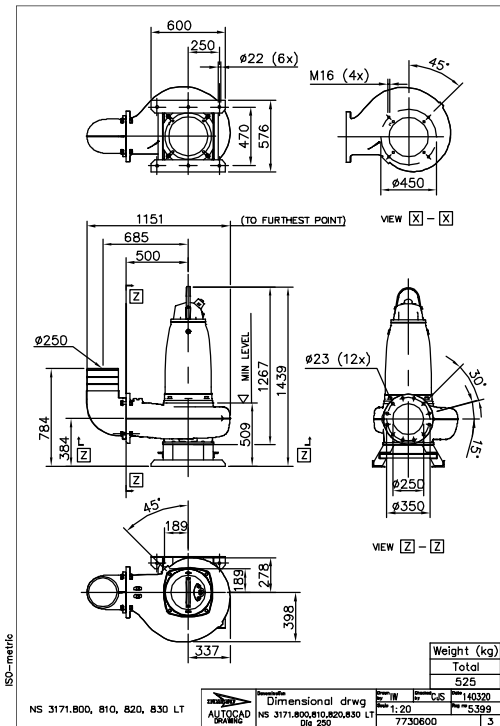

Figure 26: LT, S-installation

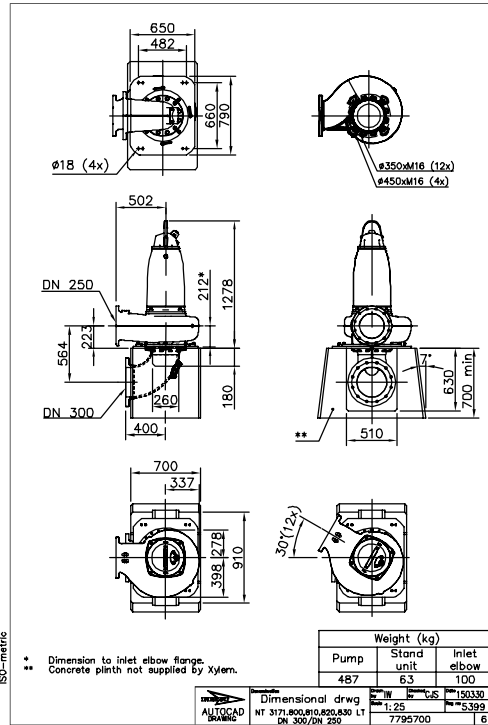

Figure 27: LT, T-installation

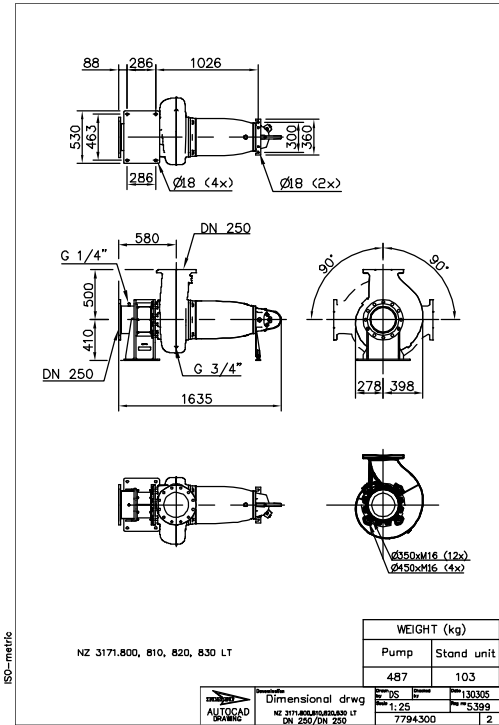

Figure 28: LT, Z-installation

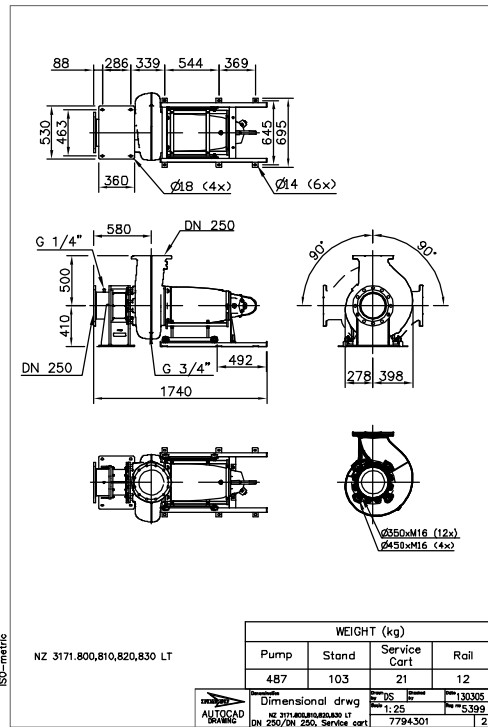

Figure 29: LT, Z-installation

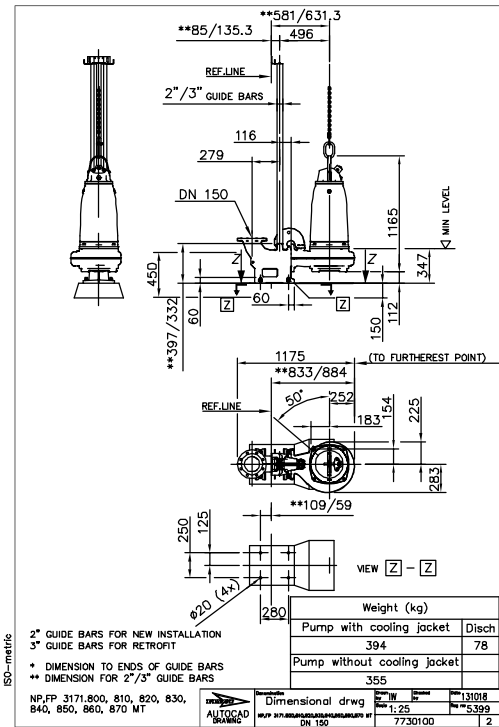

Figure 30: MT, P-installation



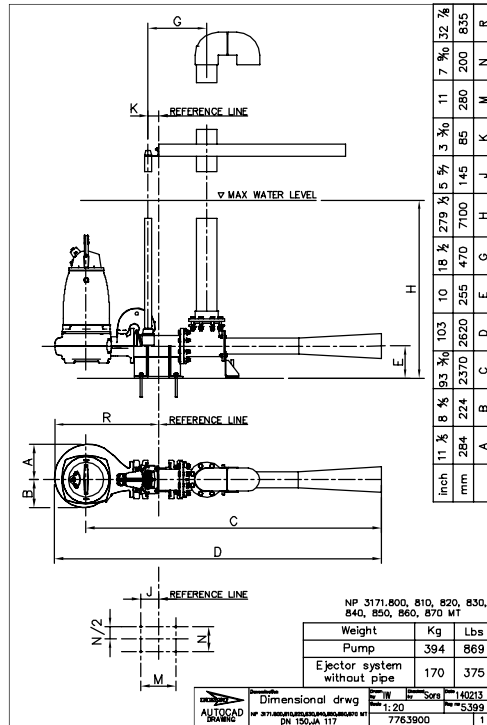

Figure 31: MT, P-installation

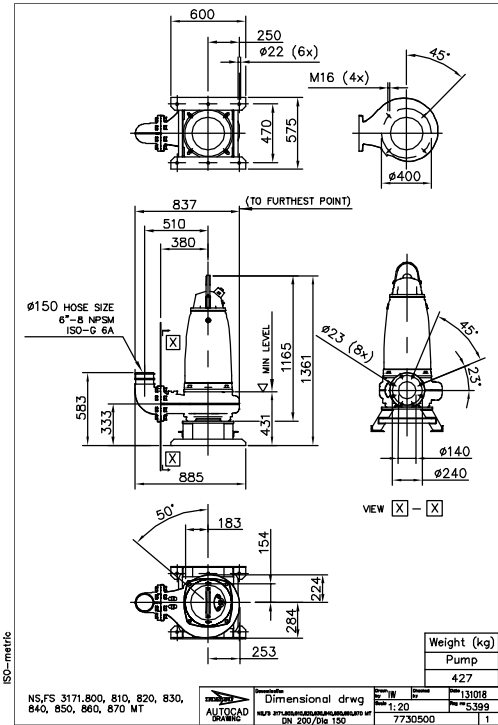

Figure 32: MT, S-installation

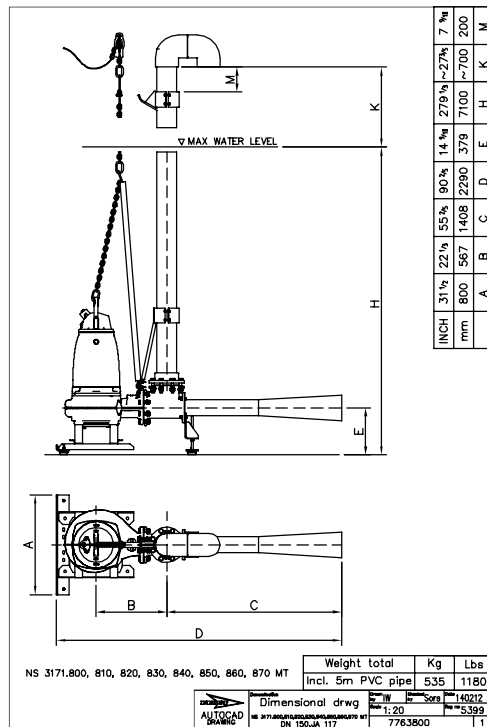

Figure 33: MT, S-installation

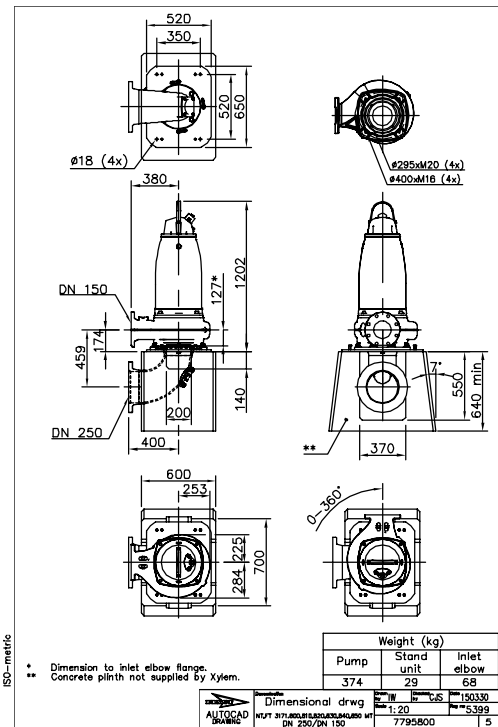

Figure 34: MT, T-installation



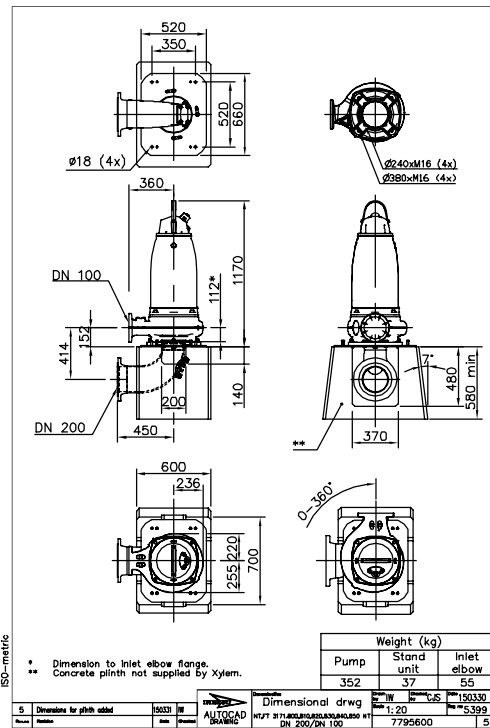

Figure 39: HT, T-installation

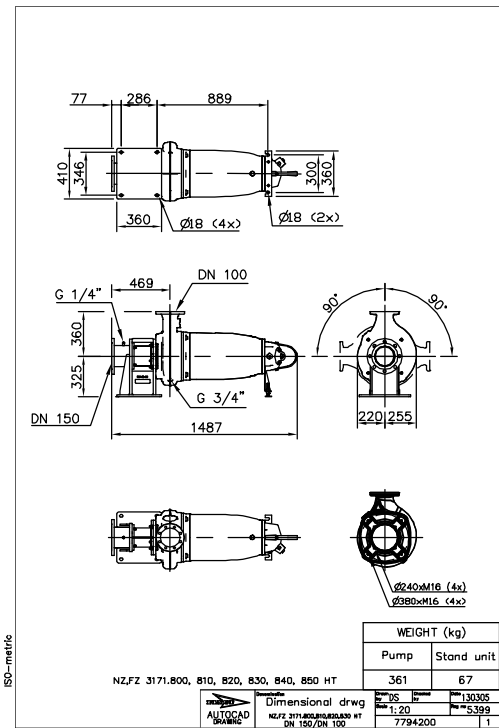

Figure 40: HT, Z-installation

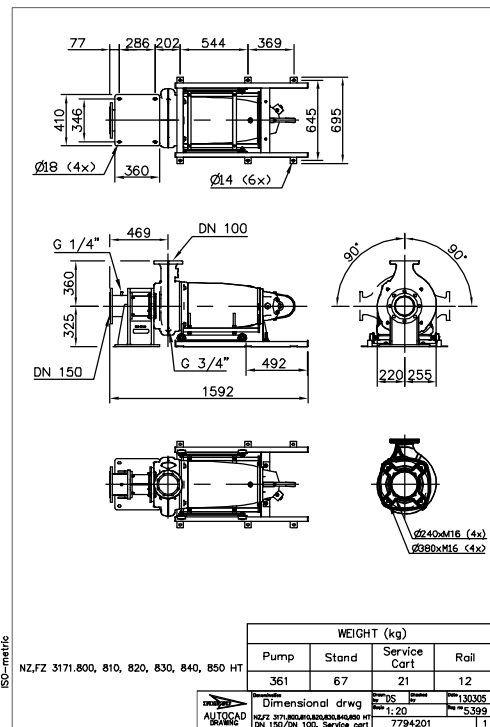

Figure 41: HT, Z-installation

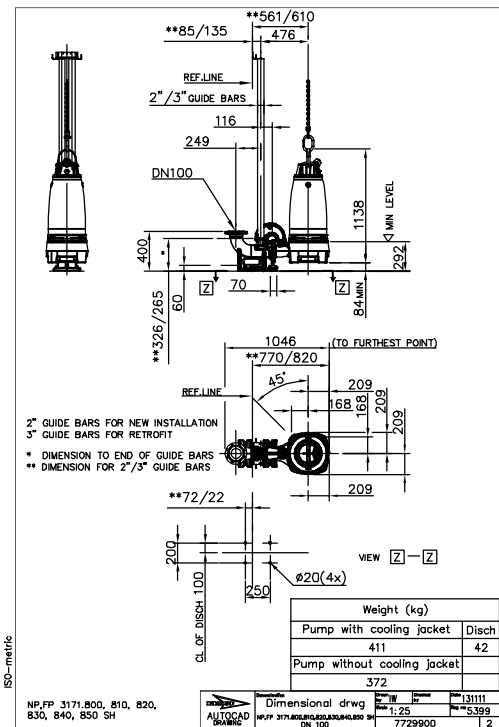

Figure 42: SH, P-installation

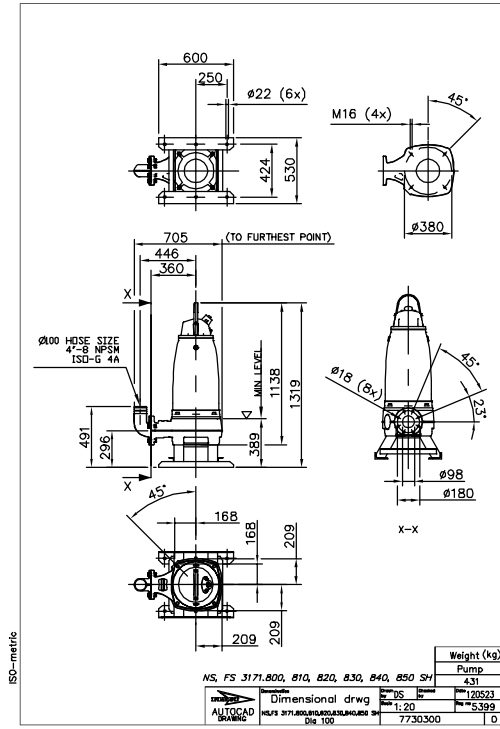

Figure 43: SH, S-installation

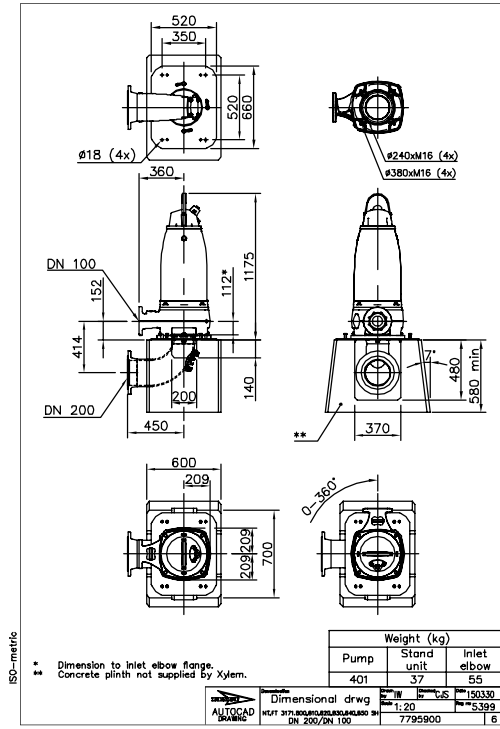

Figure 44: SH, T-installation

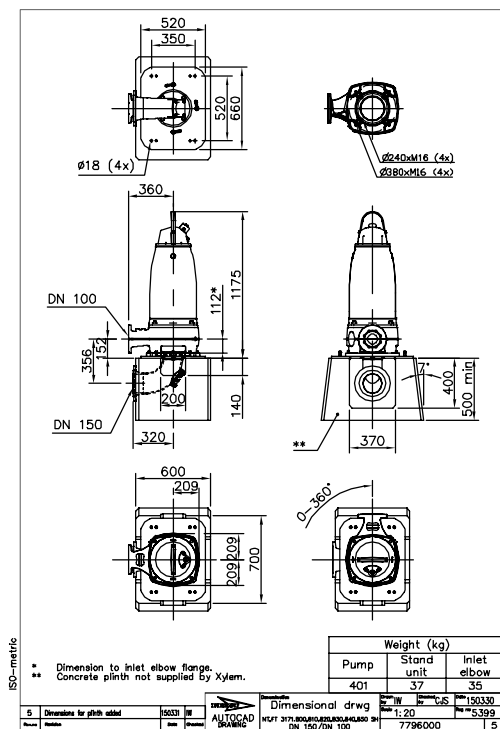

Figure 45: SH, T-installation

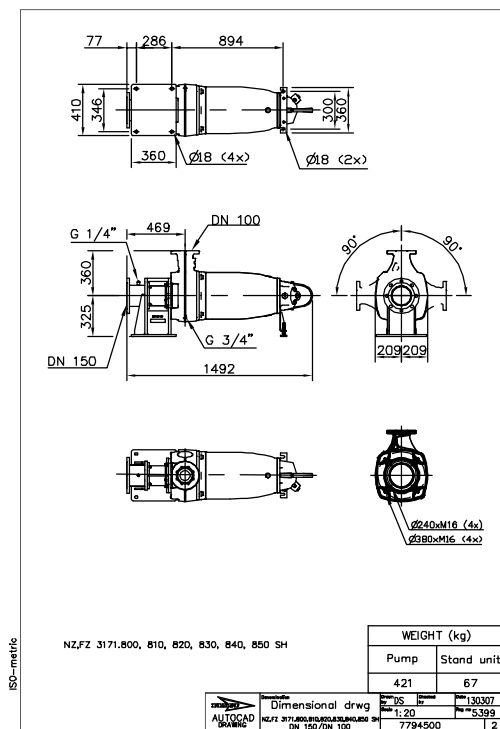

Figure 46: SH, Z-installation

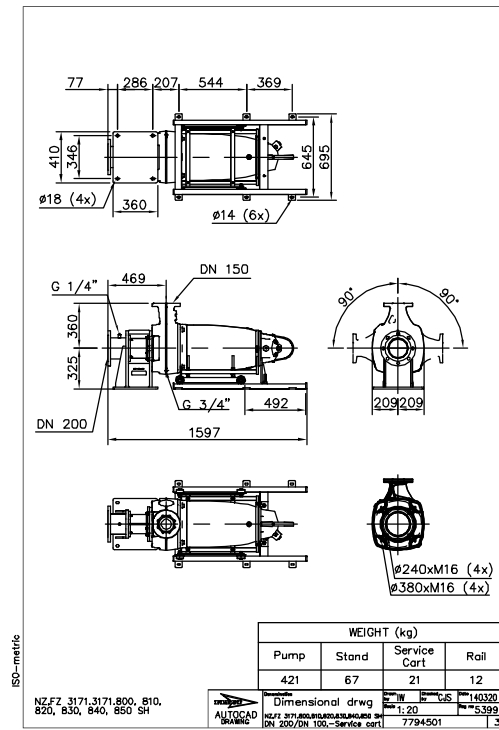

Figure 47: SH, Z-installation





# Xylem |'zīləm|

- 1) The tissue in plants that brings water upward from the roots;
- 2) a leading global water technology company.

We're a global team unified in a common purpose: creating advanced technology solutions to the world's water challenges. Developing new technologies that will improve the way water is used, conserved, and re-used in the future is central to our work. Our products and services move, treat, analyze, monitor and return water to the environment, in public utility, industrial, residential and commercial building services settings. Xylem also provides a leading portfolio of smart metering, network technologies and advanced analytics solutions for water, electric and gas utilities. In more than 150 countries, we have strong, long-standing relationships with customers who know us for our powerful combination of leading product brands and applications expertise with a strong focus on developing comprehensive, sustainable solutions.

For more information on how Xylem can help you, go to [www.xylem.com](http://www.xylem.com)



**xylem**  
Let's Solve Water

Xylem Water Solutions Global  
Services AB  
361 80 Emmaboda  
Sweden  
Tel: +46-471-24 70 00  
Fax: +46-471-24 74 01  
<http://tpi.xylem.com>  
[www.xylemwatersolutions.com/  
contacts/](http://www.xylemwatersolutions.com/contacts/)

Visit our Web site for the latest version of this document and more information

The original instruction is in English. All non-English instructions are translations of the original instruction.

© 2012 Xylem Inc