

Wear resistant submersible motor pumps for clear and drainage water.

H16

Application

Pump for conveying clean or soiled water also containing abrasive sand or sludge. Application areas include water table drawdown, drainage of construction sites, subways or shafts, supply of industrial water, application board ships, emergency deployment for flooding etc.

DIN EN 12050-2: Design tested and monitored.

Installation: Stationary or mobile. Version with float switch for use as automatic water level controlled drainage pump.

Pumped medium: Clear- or drainage water with abrasive (e.g. sandy) contents. Max. temperature of pumped medium: 40° C, for brief periods up to 60° C.

Operating mode: Continuous operation (S1).

At medium temperature 41-60° C:
 Intermittent operation (S3 30%).

Design

Fully submersible pump, consisting of:

Pump: Single-stage centrifugal pump with horizontal discharge.

Impeller: Open multi-blade impeller, free passage 10 mm.

Motor: Fully submersible motor, sealed against pressurized water, oil-filled. Insulation class H, Protection rating IP 68. Thermal sensor for temperature monitoring in the winding. Electrical compartment is separate from motor. Connecting cable: H07RN-F3G1

Shaft/bearing: strongly dimensioned chrome steel motor shaft, lifetime-lubricated roller bearings.

Seal: Triple radial seal.

Conveying capacities

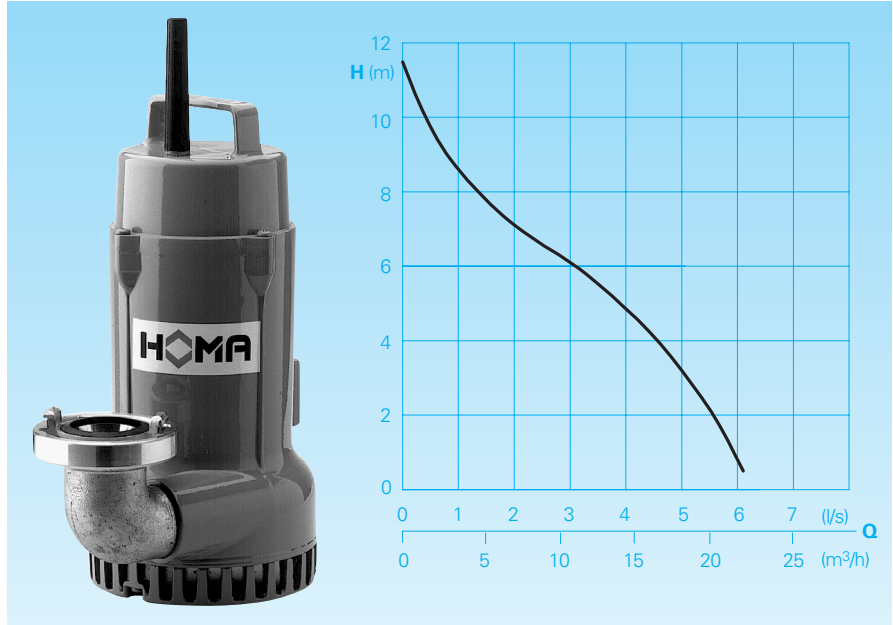

Technical data

Pump type	Motor input		Voltage 50 Hz (V)	Nomial current (A)	Weight (kg)
	P ₁ (kW)	P ₂ (kW)			
H16 W(A)	1,1	0,6	230/1Ph	5,1	11,0

Rotational speed: 2900 rpm

Discharge: G1 1/2

Model A: with automatic float switch
 HOMA-Nivomatik

Materials

Motor housing, motor bearing housing, motor housing cover, suction sieve,	Aluminium
Suction cover	Aluminium rubberized
Impeller	Cast iron EN-GJL-250
Motor shaft, screws	Stainless steel
Elastomers	NBR

Scope of supply

Pump with 90° connection bend and STORZ-fixed coupling size C, 10 m connecting cable.

Model W (230 V/1 Ph):

With Switchgear W1, motor protection, ON-OFF-switch and mains plug.

Model A: Additionally with automatic float switch on pump lid, switchgear WA1 with Manual/Auto-switch.

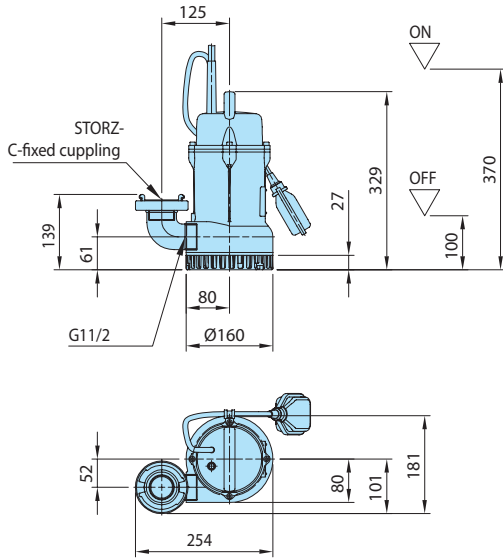

Shaft installation with pressure pipe, level control and switchgear

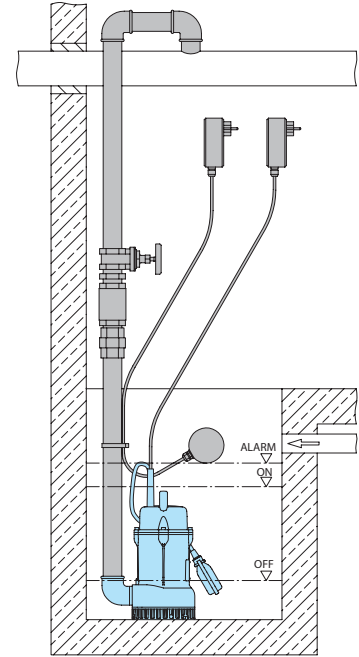

Accessories

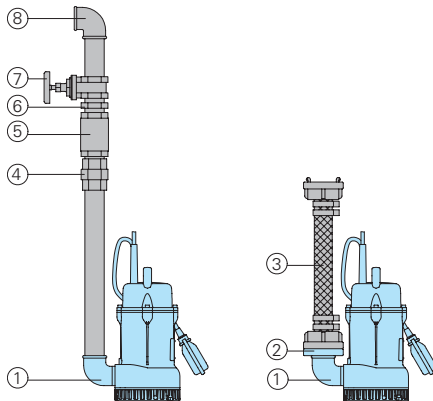

Description	Size	Part no.	Description	Size	Part no.
① Connection bend 90°, galvanized	BSP 1 1/2" F/M	2111505	○ Fault-current circuit breaker 2-pin, Fi 16/0.03 A		1561160
Fixed coupling, brass	BSP 1 1/2" M	2005513	○ Mains-dependent alarm control unit AL3 with connector for 9 V rechargeable battery (see below) for operation independent of mains power supply, with built-in signal transmitter, float switch and 10 m of cable. Main phase connection 230V/1Ph		1586141
STA-threaded hose-fitting, brass	BSP 1 1/2" M	2001513	9 V rechargeable battery for mains-independent alarm		1952215
② STORZ-fixed coupling	C-G 1 1/2" M in Scope of supply		○ For pump controllers and switchgears for mobile and stationary applications, measuring systems and monitoring devices, see HOMA accessories		
③ PVC-hose, per m	1 1/2" Ø 38 mm	2621500			
Plastic spiral hose, per m	1 1/2" Ø 38 mm	2632042			
Hose coupling, brass	1 1/2"	2003513			
STORZ-hose-coupling	C-38 Ø	2013002			
Hose clamp	1 1/2"	2304854			
④ Transition screw connection, galvanized	BSP 1 1/2" M/F	2114305			
⑤ Non-return valve, brass	BSP 1 1/2" F	2211313			
⑥ Double nipple, galvanized	BSP 1 1/2" M	2009020			
⑦ Shut-off gate valve, brass	BSP 1 1/2" F	2216015			
⑧ Connection bend 90°, galvanized	BSP 1 1/2" F	2113605			
T-piece for merging the pressure pipe in double pump stations, galvanized	BSP 1 1/2" F	2114302			



We reserve the right to alter our specifications without notice!