

JUNG PUMPEN HEBEFIX

ABOVE FLOOR SUMP

APPLICATION

The above floor sump Hebefix is a drainage pump station in mini size. It consists of a mountable or suspendable plastic tank (approx. 25 l) with an additional sleeve for 40 mm PVC/HT pipes at the top and three additional inlet on the sides. The lateral lower inlet sleeves have been designed for 50 mm PVC/HT pipes. The cellar drainage pump U3KS intended for the Hebefix tank is connected at the prepared pipe connection and pumps the grey water running in automatically to the next sewage pipe. Thus, a drain for a washbasin can be installed at any requested site - also below the backpressure level - without a lot of cumbersome masonry work and without excavating a pit. A washing machine, a dish washer, a bathtub and a shower tray can be connected as well.

The connection of a ventilation pipe passed to the roof prevents odours. If no ventilation pipe is connected, the activated carbon filter prevents annoyance caused by offensive odour. The installation of an alarm system (AWR 3) is recommended. It warns against impermissibly high water levels and switches the washing machine off, if and when required.

The scope of delivery includes the plastic tank with integrated connection hose, clamps, swing-type check valve as supplementation kit for U3 KS, activated carbon filter, hose connection for the washing machine (top, lateral connections), rubber feet and wall attachment parts (without pump).

The unit is in conformity with the specification of German / European standard 12050.



Hebefix with U3KS and special float switch



Hebefix with U3KS



- Overflow protection
- Wall-hung installation
- Alarm system possible
- Disposal of condensate from condensation boilers (only with U3KS special)
- Lid with snap-on cap
- Direction of pressure drain variable
- Swing-type check valve
- Activated carbon filter

PERFORMANCE

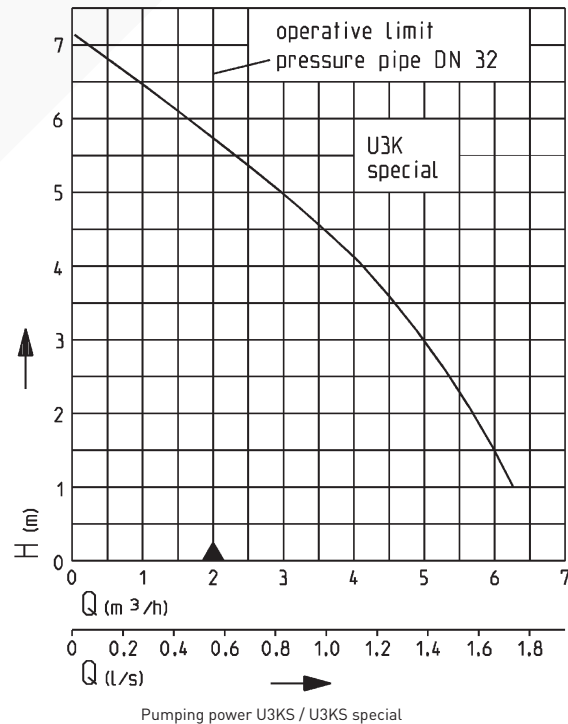

We reserve the right to change specifications without notice Pump performance is subject to ISO 9906 tolerances

The minimum flow velocity in the pressure piping must be 0.7 m/s according to EN 12056. This data is represented in the performance curve as a limit of application.

JUNG PUMPEN HEBEFIX

ABOVE FLOOR SUMP

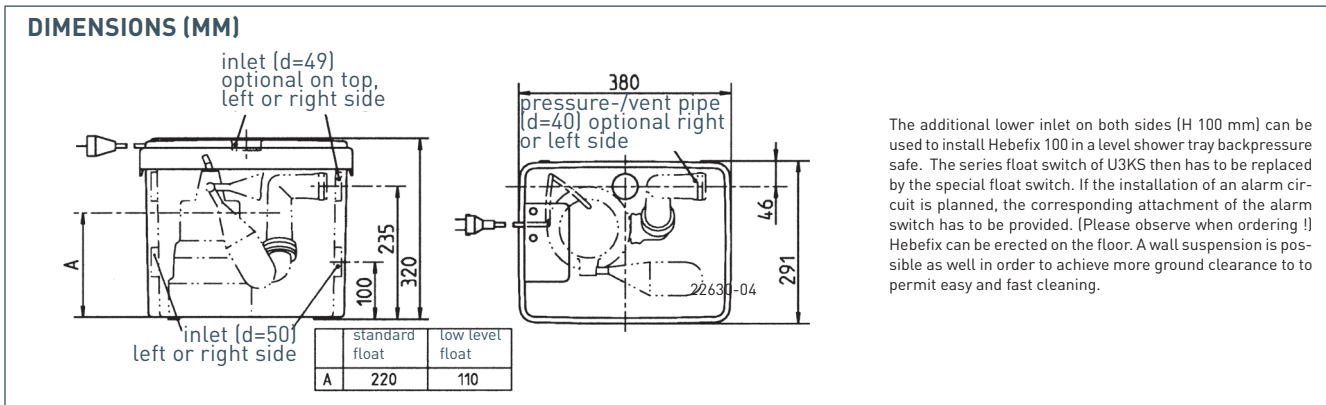
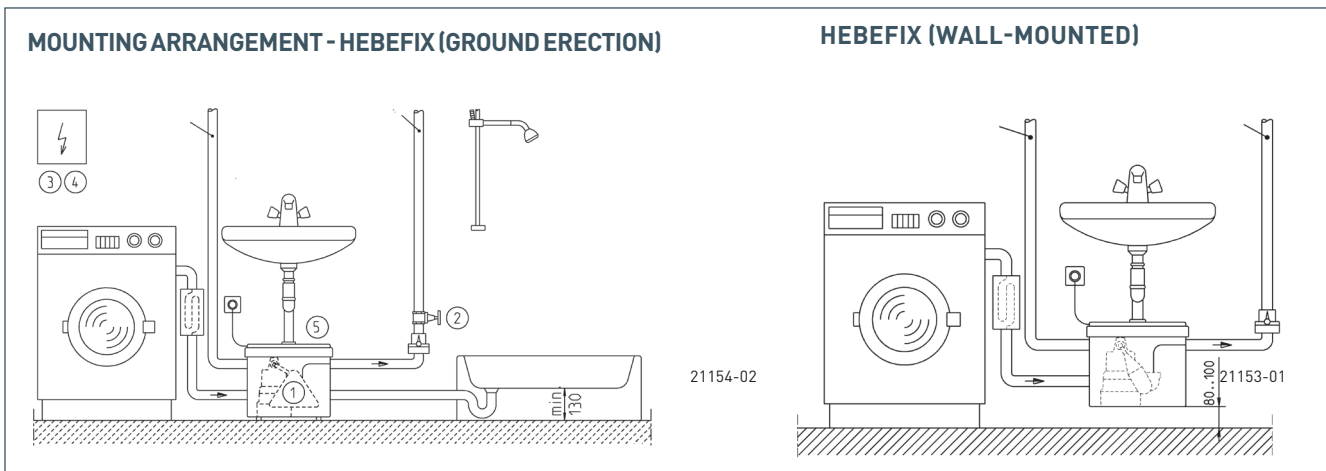

ABOVE FLOOR SUMP

Type	Largest height x width x depth	Connections	Weight approx.	Code No.
Hebefix tank, white without pump	320 x 380 x 291 mm	3 x 40 mm 2 x 50 mm	3 kg	JP01063
placeable pump U3KS	(cable length 4 m)			JP00206
or U3KS	(cable length 10 m)			JP09808
or U3KS special	for condensate from condensation boilers			JP09563

ACCESSORIES

	Art.-Nr.
1 Special float switch for low switching heights (switching height ON approx. 110 mm, OFF approx. 50 mm)	JP44795
2 Stop valve 1¼" (DN 32), PN 16	JP44785
Ball valve 1¼" (DN 32), PVC, for U3KS special	JP46111
3 Alarm unit AGR mains-dependent, with potential-free make contact	JP44893
Alarm unit washing machine stop AWR with reed switch, separate, mains-dependent and 3 m cable	JP44897
Fastener for alarm switch (only U3KS with special float switch)	JP28191
4 Rechargeable battery for mains-independent alarm	JP44850

PERFORMANCE

Type	Delivery head H [m]	1	2	3	4	5	6
U3KS	Flow rate Q [m³/h]	6.5	5.5	5.0	4.0	3.0	1.5
U3KS spezial		6.5	5.5	5.0	4.0	3.0	1.5