

Grinder - 10002 Muffin Monster™ - Open channel series

SULZER

The 10002 Muffin Monster sewage grinder is designed to protect pumps and other equipment by grinding down the toughest wastewater solids. Its dual-shafted, slow-speed, high-torque design shreds tough solids that typically cause problems in the wastewater treatment process system. Its compact design fits into areas with limited space while providing the necessary power for downstream protection.

Construction

- Open channel configuration
- Cutter chamber opening height of 185 mm
- Hardened alloy steel cutters (standard), or optional stainless steel cutters available, 120 mm diameter
- Ductile iron housings
- Hardened alloy steel shafts, 50 mm hex
- Mechanical seals with tungsten carbide faces (6 bar working pressure) or optional severe-duty seals available (10.3 maximum dry working pressure)
- Available with channel or wall mounted frame for easy installation

Performance

- Flow rates up to 41.4 m³/hr

Applications

- Pump stations
- Collection systems
- Headworks at wastewater treatment
- Private facility discharge to municipal sewer system
- Prison sewage system protection
- Industrial wet waste grinding and maceration

Monster Renew grinder

In place of repairing a worn grinder, choose a Monster Renew unit. Sulzer provides a new, factory-built grinder cartridge to replace the worn grinder cartridge. Remove the motor and reducer from the worn unit, install the motor and reducer on the Monster Renew unit, and install the new assembly in place of the worn unit. Benefits include:

- Minimizes operational downtime
- Quick turnaround
- All new parts
- Great time to upgrade unit
- Full factory warranty on the Monster Renew grinder cartridge

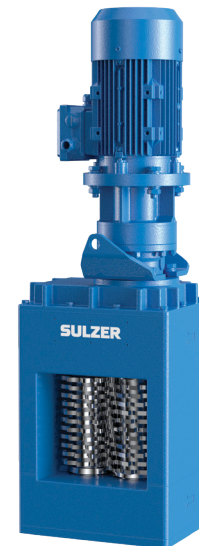

Muffin Monster motor assembly

- 1.5 kW gear motor standard, 2.2 kW gear motor optional
- Optional explosion proof (1.5 kW, 2.2 kW and 4.0 kW) and immersible electric motors (1.5 kW, 2.2 kW and 3.7 kW) available
- 25:1 reducer, cycloidal design

Muffin Monster frame options

- Adapt grinders for easy installation
- Channel frames to fit most channel types
- Wall frames to mount on flat or round walls
- Type 304 or 316 stainless steel construction
- Guide rails for easy installation and maintenance

Muffin Monster controller

- Ensures maximum grinding ability with minimum stoppage
- Designed and programmed for specified motor

Muffin Monster grinder cutters

Tooth count	Thickness	Material
7-tooth	11 mm	Hardened alloy steel*
11-tooth	8 mm	Hardened alloy steel*
17-tooth Wipes Ready™	11 mm	Hardened alloy steel

* Available in optional stainless steel.

Muffin Monster grinder materials

Part	Standard
Housings	Ductile iron
Cutters	Hardened alloy steel**
Shafts	Hardened alloy steel
Mechanical seals	Tungsten carbide faces
Gaskets	Cork and rubber***

** Available in optional stainless steel.

*** Available in optional Viton™.

For guidance in selecting a 10002 Muffin Monster, please contact Sulzer.

Performance curves

Model 10002 Open Channel

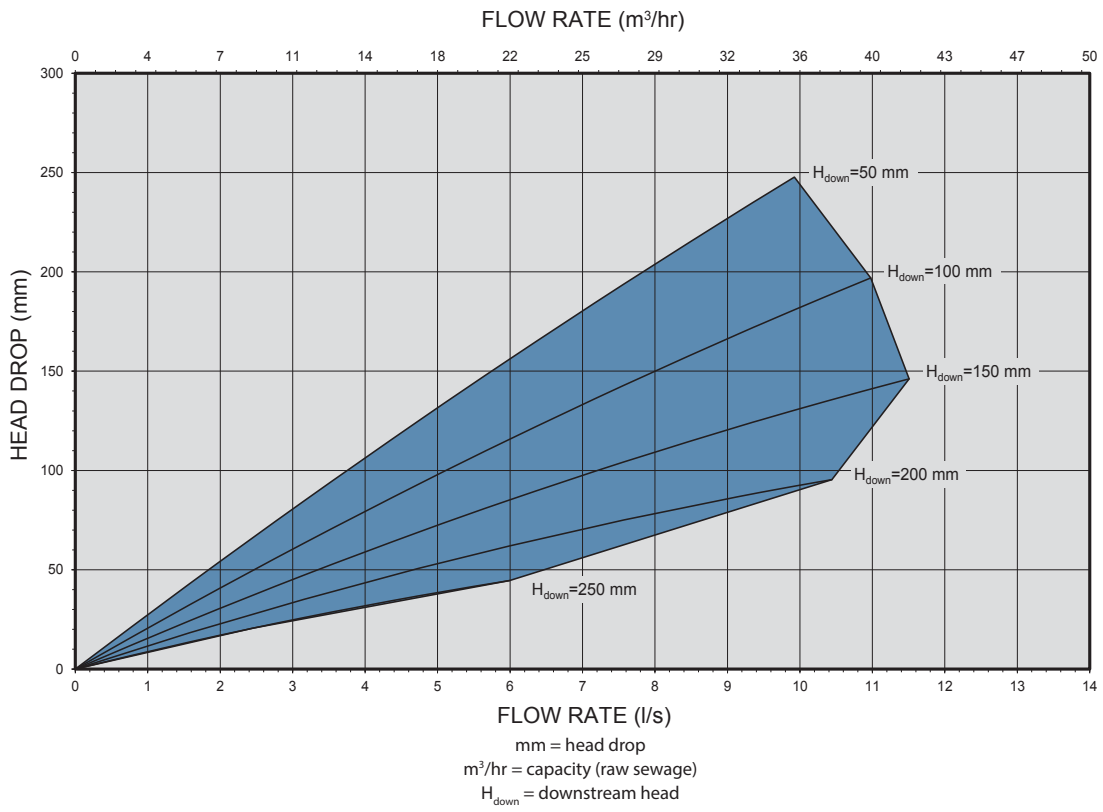

Dimensions (mm)

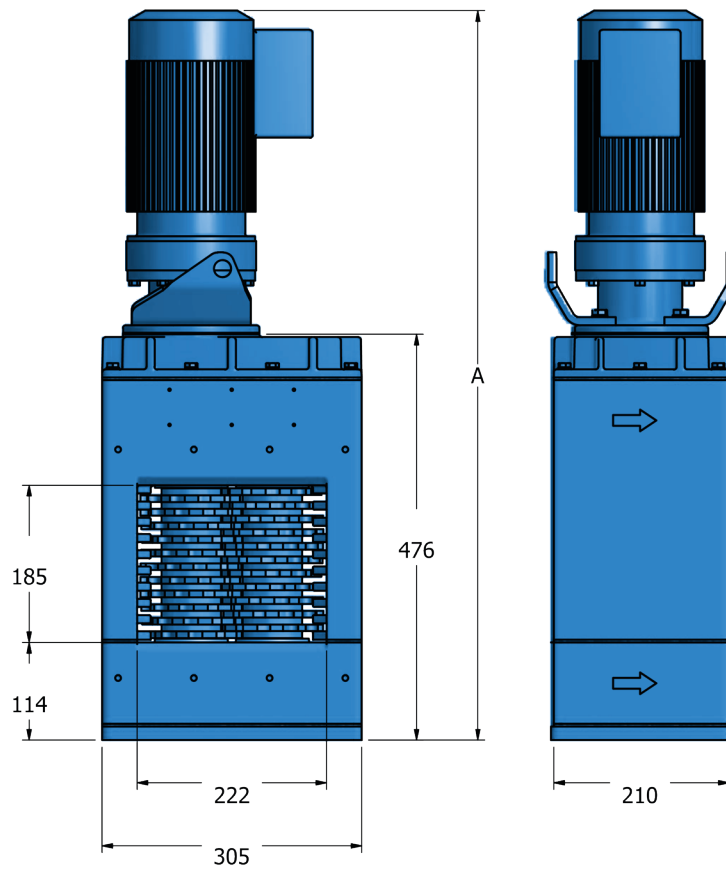

Open channel model	Flow rate ¹ - m ³ /hr	Head drop - mm	Standard dimensions ² - mm		Approximate net weight ³ - kg
			A (IP55)	A (IP68)	
10002-0008-DI	41.4	146	1'015	1'160	255

1. Flow based on optimum channel conditions. Consult factory for analysis of application.

2. Drive dimensions are a maximum based on a unit with a 2.2 kW drive. Extended drive shafts are available on request.

3. Weight is based on a unit with a 2.2 kW IP68 drive.

