

In-line Twin Pump

Etaline Z



Fixed Speed / Variable Speed
50 Hz

Type Series Booklet



Legal information/Copyright

Type Series Booklet Etaline Z

All rights reserved. The contents provided herein must neither be distributed, copied, reproduced, edited or processed for any other purpose, nor otherwise transmitted, published or made available to a third party without the manufacturer's express written consent.

Subject to technical modification without prior notice.

© KSB SE & Co. KGaA, Frankenthal 22/10/2020

Contents

Heating / Air-conditioning / Ventilation 4

- In-line Twin Pumps..... 4
- Etaline Z..... 4
 - Main applications..... 4
 - Fluids handled 4
 - Related documents 4
 - Operating data..... 4
 - Design details 5
 - Designation 7
 - Materials..... 8
 - Coating and preservation 9
 - Product benefits..... 9
 - Product information 9
 - Acceptance tests and warranty 9
 - Overview of product features / selection tables 10
 - Pressure limits and temperature limits 14
 - Technical data 15
 - Selection charts 22
 - Characteristic curves..... 23
 - Dimensions 41
 - Connections..... 50
 - Flange design 51
 - Installation types..... 52
 - Accessories..... 53
 - General assembly drawings 54

Heating / Air-conditioning / Ventilation

In-line Twin Pumps

Etaline Z



i The product illustrated as an example may include options incurring a surcharge.

Main applications

- Service water supply systems
- Heating systems
- Industrial recirculation systems
- Air-conditioning systems
- Cooling circuits
- Water supply systems¹⁾

Fluids handled

- Fluids not chemically or mechanically aggressive to the materials

Further information on fluids handled

Overview of fluids handled (⇒ Page 10)

Related documents

Information/documents

Document	Reference number
Characteristic curves booklet Variable speed version	1161.4
Type series booklet KSB SuPremE	4075.53
Type series booklet PumpDrive 2 / PumpDrive 2 Eco	4074.5
Type series booklet PumpDrive R	4073.5
Type series booklet PumpMeter	4072.5

Operating data

Operating properties

Characteristic	Value		
	Single-pump operation	Parallel operation	
Flow rate	Q [m ³ /h]	≤ 602,5	≤ 1095
	Q [l/s]	≤ 167	≤ 304,5
Head	H [m]	≤ 38,5	≤ 38,5
Fluid temperature	T [°C]	≥ -30	≥ -30
		≤ +140	≤ +140
Operating pressure	p [bar]	≤ 16 ²⁾	≤ 16 ²⁾

¹ No drinking water in acc. with UBA (German drinking water regulations to German Environment Agency)

² The sum of inlet pressure and shut-off head must not exceed the value indicated.

Design details

Design

- In-line twin pump in closed-coupled design
- Single-stage
- Horizontal installation / vertical installation
- Rigid connection between pump and motor
- Back pull-out design
- Fixed speed version (without PumpDrive 2 / PumpDrive 2 Eco / PumpDrive R) / variable speed version (with PumpDrive 2 / PumpDrive 2 Eco / PumpDrive R)

Pump casing

- Radially split volute casing
- In-line design

Drive (fixed speed version)

Standard design:

- KSB/Siemens surface-cooled IEC frame three-phase squirrel-cage motor
- Efficiency class IE1 (size 71/80) / IE3 (from size 90) to IEC 60034-30
- Rated voltage (50 Hz) 230 V / 400 V \leq 2.20 kW
- Rated voltage (50 Hz) 400 V / 690 V \geq 3.00 kW
- Rated voltage (60 Hz) - / 460 V \leq 2.20 kW
- Rated voltage (60 Hz) 460 V / - \geq 3.00 kW
- Type of construction IM V1
- Enclosure IP55
- Duty cycle: continuous duty S1
- Thermal class F with temperature sensor, 1 PTC thermistor (size 80/90) / 3 PTC thermistors (from size 100)

Explosion-proof design:

- KSB surface-cooled IEC three-phase current squirrel-cage motor
- Efficiency class IE2 / IE3 to IEC 60034-30
- Rated voltage (50 Hz) 230 V / 400 V \leq 2.50 kW
- Rated voltage (50 Hz) 400 V / 690 V \geq 3.30 kW
- Rated voltage (60 Hz) - / 460 V \leq 2.50 kW
- Rated voltage (60 Hz) 460 V / - \geq 3.30 kW
- Type of construction IM V1
- Enclosure IP55
- Duty cycle: continuous duty S1
- II 3G Ex ec IIC T3 Gc
- II 2G Ex eb IIC T3 Gb
- II 2G Ex db (eb) IIB T4 Gb
- II 2G Ex db (eb) IIC T4 Gb

Drive (variable speed version)

KSB SuPremE motor:

- Surface-cooled KSB SuPremE motor, IEC-compatible, magnetless synchronous reluctance motor³⁾ (PumpDrive 2 / PumpDrive 2 Eco / PumpDrive R required)
- Efficiency class IE4/IE5 to IEC TS 60034-30-2:2016
- Mounting points to EN 50347:2001
- Envelope dimensions to DIN VDE 42673-4:2011-07
- Type of construction IM V1
- Enclosure IP55
- Duty cycle: continuous duty S1
- Thermal class F with temperature sensor, 3 PTC thermistors
- Shaft centreline height 71 to 225 mm
- Rated power 0.55 kW to 45 kW
- Rated speed 1500 rpm or 3000 rpm
- Frequency 50 Hz / 60 Hz (PumpDrive input)
- Voltage 380 V to 480 V (PumpDrive input)

KSB SuPremE X1:

- With terminal box for connecting to PumpDrive 2 or PumpDrive R for mounting on walls and in control cabinets

KSB SuPremE X2:

- Equipped for being fitted with a motor-mounted PumpDrive 2

PumpDrive 2 / PumpDrive 2 Eco:

- Self-cooling frequency inverter of modular design for the continuously variable speed control of asynchronous motors and synchronous reluctance motors by means of analog standard signals, a field bus or the control panel
- Identical design of frequency inverter for motor mounting, wall mounting and cabinet mounting
- Mains voltage 3~ 380 V AC -10 % to 480 V AC +10 %
- Mains frequency 50 Hz to 60 Hz \pm 2 %

PumpDrive R:

- Self-cooling frequency inverter of modular design for the continuously variable speed control of asynchronous motors and synchronous reluctance motors, such as KSB SuPremE motors or permanent magnet synchronous motors, by means of analog standard signals, a field bus or the control panel
- Identical design of frequency inverter for the mounting types wall mounting and cabinet mounting
- Mains voltage 3~ 380 V AC -10 % to 480 V AC +10 %
- Extended mains voltage range (on request)
- Mains frequency 50 Hz to 60 Hz \pm 2 %
- Extended power range with a nominal power of 110 kW (standard) or 1400 kW (on request)

PumpMeter:

- Intelligent pressure transmitter for pumps, with on-site display of measured values and operating data
- For recording the load profile of the pump
- Supplied completely assembled and parameterised for the individual pump

KSB Guard

- System for monitoring the pump's condition by means of temperature and vibration sensors
- Measured values and operating data may be retrieved via the KSB Guard app and the web portal at any time.

³ Motor sizes 0.55 kW / 0.75 kW with 1500 rpm are designed with permanent magnets.

Shaft seal

- Standardised mechanical seal to EN 12756
- Shaft equipped with replaceable shaft protecting sleeve in the shaft seal area

Twin pump

- Two separate centrifugal pump hydraulic systems in one pump casing with a spring-loaded changeover flap located in the discharge nozzle
- Changeover flap housing made of Rilsan (nominal diameter 32 to 80)
- Changeover flap housing made of bronze (nominal diameter 100 to 200 inclusive)
- Flaps, springs, stems made of chrome steel
- Manual venting of the mechanical seal chamber through two integrated vent valves
- Single-pump operation (stand-by operation) / parallel operation (additional pump start-up in case of peak load)
- Redundant dual-pump operation through M12 module (accessory) without higher-level controller

Impeller type

- Closed radial impeller

Bearings

- Radial ball bearings in the motor housing
- Grease lubrication

Designation

Designation example

Position																																											
1	2	3	4	5	6	7	8	9	10	11	12	13	14	15	16	17	18	19	20	21	22	23	24	25	26	27	28	29	30	31	32	33	34	35	36	37	38	39	40	41	42	43	44
E	T	L	-	0	3	2	-	0	3	2	-	1	6	0	-	G	G	S	A	V	0	1	D	2	1	1	0	0	2	e	x	B	K	S	B	I	E	3	P	D	2	E	M
See name plate and data sheet																						See data sheet																					

Designation key

Position	Code	Description	
1-4	Pump type		
	ETL	Etaline	
	ETLZ	Etaline Z (refer to Etaline to select back pull-out unit)	
5-16	Size [mm], e.g.		
	032	Nominal suction nozzle diameter	
	032	Nominal discharge nozzle diameter	
	160	Nominal impeller diameter	
17	Pump casing material		
	G	Cast iron EN-GJL-250 / A48CL35	
18	Impeller material		
	G	Cast iron EN-GJL-250 / A48CL35	
	C	Stainless steel 1.4408 / A743CF8M	
	B	Bronze CC480K-GS / B30 C90700	
19	Design		
	H	Approved for drinking water to ACS	
	K	Approved for drinking water to KSB standard	
	S	Standard	
	U	Approved for drinking water to UBA	
	W	Approved for drinking water to WRAS	
	X	Non-standard (BT3D, BT3)	
20	Casing cover		
	A	Conical seal chamber	
21	Shaft seal type		
	V	Single mechanical seal with vented chamber (A-type cover)	
22-23	Seal code, single mechanical seal		
	01	Q1Q1VGG	1 (ZN1181) $\geq -20 - \leq +110$ [°C]
	06	U3BEGG (shaft units 25, 35)	RMG13G606 $\geq -30 - \leq +140$ [°C]
	07	Q1Q1EGG	1A (ZN1181) $\geq -30 - \leq +110$ [°C]
	09	U3U3VGG	MG13G60 $\geq -20 - \leq +110$ [°C]
	10	Q1Q1X4GG	1 (ZN1181) $\geq -20 - \leq +110$ [°C]
	11	BQ1EGG-WA (WA = drinking water)	1 (ZN1181) $\geq -30 - \leq +110$ [°C]
	22	AQ1EGG (shaft unit 55)	M32N69 $\geq -30 - \leq +140$ [°C]
	66	Q7Q7EGG	MG13G6 $\geq -30 - \leq +120$ [°C]
24	Scope of supply		
	A	Pump only (Fig. 0)	
	D	Pump, motor	
	E	Back pull-out unit	
25	Shaft unit		
	2	Shaft unit 25	
	3	Shaft unit 35	
	5	Shaft unit 55	
26-29	Motor rating P_N [kW]		
	0002	0,25	
	
	0550	55,00	
30	Number of motor poles		
31-32	Explosion protection		
	ex	With explosion-proof motor	
	--	Without explosion-proof motor	
33	Product generation		

Position	Code	Description
33	B	Etaline / Etaline Z
34-36	Motor manufacturer	
	KSB	KSB (ISO 9001)
	SIE	Siemens
	LOH	Loher
	HAL	Halter
37-39	Efficiency class	
40-43	PumpDrive	
	PD2	PumpDrive 2
	PD2E	PumpDrive 2 Eco
	IFS	MyFlow Drive
44	PumpMeter	
	M	PumpMeter

Materials

Symbols key

Symbol	Description
X	Standard
-	Version not available / not feasible

Overview of available materials

Part No. (⇒ Page 54)	Description	Material	Material variant		
			GG	GB	GC
102	Volute casing	Grey cast iron EN-GJL-250 / A 48 Cl. 35B	X	X	X
161	Conical casing cover	Grey cast iron EN-GJL-250 / A 48 Cl. 35B	X	X	X
210	Shaft	Tempered steel C45+N	X	X	X
		Stainless steel 1.4571 (optional)	X	X	X
230	Impeller	Grey cast iron EN-GJL-250 / A 48 Cl. 35B	X	-	-
		Bronze CC480K-GS / B30 C90700	-	X	-
		Stainless steel 1.4408 / A743 Gr. CF8 M	-	-	X
341	Drive lantern	Grey cast iron EN-GJL-250 / A 48 Cl. 35B	X	X	X
400	Sealing elements	DPAF, asbestos-free	X	X	X
502.01	Casing wear ring, suction side	Grey cast iron EN-GJL-250 / A 48 Cl. 35B	X	X	X
		Bronze CC495K-GS	-	X	-
502.02	Casing wear ring, discharge side	Grey cast iron EN-GJL-250 / A 48 Cl. 35B	X	X	X
		Bronze CC495K-GS	-	X	-
523	Shaft sleeve	Stainless steel (CrNiMo steel)	X	X	X
902	Studs	Steel 8.8	X	X	X
903	Plug	Steel	X	X	X
920	Nut	8+A2A / 8+B633 SC1 TP3	X	X	X
920.95	Impeller nut	Stainless steel (CrNiMo steel)	X	X	X
		Steel 8	X	X	-

Coating and preservation

- Coating and preservation to KSB standard

Product benefits

- Maximum energy efficiency through demand-driven operation in combination with KSB SuPremE IE4/IE5 motor⁴⁾ to IEC TS 60034-30-2:2016
- PumpDrive 2 / PumpDrive 2 Eco perfectly matched to pump and motor by default factory parameter settings
- Motor-mounted variable speed system up to 45 kW saves space
- Pump operation made fully transparent with PumpMeter

Product information

Product information as per Regulation No. 1907/2006 (REACH)

For information as per chemicals Regulation (EC) No. 1907/2006 (REACH), see <http://www.ksb.com/reach>.

Product information as per Regulation No. 547/2012 (for water pumps with a maximum shaft power of 150 kW) implementing "Ecodesign" Directive 2009/125/EC

- Minimum efficiency index: see data sheet
- The benchmark for the most efficient water pumps is MEI ≥ 0.70 .
- Year of construction: see data sheet
- Manufacturer's name or trade mark, commercial registration number and place of manufacture: see data sheet or order documentation
- Product's type and size identifier: see data sheet
- Hydraulic pump efficiency (%) with trimmed impeller: see data sheet
- Pump performance curves, including efficiency characteristics: see documented characteristic curve
- The efficiency of a pump with a trimmed impeller is usually lower than that of a pump with full impeller diameter. Trimming of the impeller will adapt the pump to a fixed duty point, leading to reduced energy consumption. The minimum efficiency index (MEI) is based on the full impeller diameter.
- Operation of this water pump with variable duty points may be more efficient and economic when controlled, for example, by the use of a variable speed drive that matches the pump duty to the system.
- Information relevant for disassembly, recycling or disposal at end of life: see installation/operating manual
- Information on benchmark efficiency or benchmark efficiency graph for MEI = 0.70 (0.40) for the pump based on the model shown in the Figure are available at: <http://www.europump.org/efficiencycharts>

Acceptance tests and warranty

The following acceptance tests may be performed at a surcharge:

- **Materials testing**
 - Test report 2.2
- **Final inspection**
 - Inspection certificate 3.1 to EN 10204
- **Hydraulic test**
 - The duty point of each pump is guaranteed according to ISO 9906/2B or ISO 9906/3B.
 - NPSH test
- Other inspections/tests on request

Warranties

- Warranties are given within the scope of the valid delivery conditions.

⁴ Motor sizes 0.55 kW / 0.75 kW with 1500 rpm are designed with permanent magnets.

Overview of product features / selection tables

Overview of variants

Other designs on request

Symbols key

Symbol	Description
X	Standard
-	Version not available / not feasible

Overview of Etaline / Etaline Z variants

Variant	102 / Volute casing	230 / Impeller	Mechanical seal	T [°C]	Main applications				
					Handling clean or aggressive fluids not chemically and mechanically aggressive to the pump materials	Water supply systems	Cooling circuits	Heating systems	Air-conditioning systems
GG06	Grey cast iron EN-GJL-250 / A 48 Cl. 35 B	Grey cast iron EN-GJL-250 / A 48 Cl. 35 B	SU 25, 35: mech. seal U3BEGG SU 55: mech. seal AQ1EGG	≥ -30 - $\leq +140$	-	-	-	X	-
GG10	Grey cast iron EN-GJL-250 / A 48 Cl. 35 B	Grey cast iron EN-GJL-250 / A 48 Cl. 35 B	Mech. seal Q1Q1X4GG	≥ -20 - $\leq +110$	-	X	-	-	-
GG11	Grey cast iron EN-GJL-250 / A 48 Cl. 35 B	Grey cast iron EN-GJL-250 / A 48 Cl. 35 B	Mech. seal BQ1EGG	≥ -30 - $\leq +110$	X	X	X ⁵⁾	-	X ⁵⁾
GB06	Grey cast iron EN-GJL-250 / A 48 Cl. 35 B	Bronze CC480K-DW / B30 C90700	SU 25, 35: mech. seal U3BEGG SU 55: mech. seal AQ1EGG	≥ -30 - $\leq +140$	-	-	-	X	-
GB10	Grey cast iron EN-GJL-250 / A 48 Cl. 35 B	Bronze CC480K-DW / B30 C90700	Mech. seal Q1Q1X4GG	≥ -20 - $\leq +110$	-	X	-	-	-
GB11	Grey cast iron EN-GJL-250 / A 48 Cl. 35 B	Bronze CC480K-DW / B30 C90700	Mech. seal BQ1EGG	≥ -30 - $\leq +110$	X	X	X ⁵⁾	-	X ⁵⁾

⁵ Q1Q1EGG / Q7Q7EGG, fluid handled: water, glycol with inhibitors

Overview of fluids handled
KSB EasySelect, selection software for all applications

KSB EasySelect is a comprehensive selection tool for all applications. It guides users to an optimal solution for their projects by offering a fast, easy and user-friendly way to select and configure pumps and valves. All that is required are some project-specific criteria and a few minutes' time. The tool systematically guides the user through KSB's wide range of products to the right product for the application at hand.

Other fluids upon request.

Symbols key

Symbol	Description
X	Standard
-	Version not available / not feasible

Excerpt from the overview of fluids handled with associated material variants

Fluid handled	T ⁶⁾		Materials			Shaft seal						Comments	
	Minimum	Maximum	Casing/impeller			Mechanical seal							
			Grey cast iron / grey cast iron	Grey cast iron / stainless steel	Grey cast iron / tin bronze	U3BEGG (WE 25, 35)	AO1EGG (WE 55)	Q1Q1EGG	U3U3VGG	Q1Q1X4GG	BQ1EGG		Q7Q7EGG
[°C]		GG	GC	GB	6	22	7	9	10	11	66		
Water													
Service water	-	≤ +110	X	-	-	-	-	-	-	X	-	-	CrNiMo cast steel can be used.
Fire-fighting water ⁷⁾	-	≤ +60	-	-	X	-	-	-	-	X	-	-	Contact KSB for supply to VdS guidelines.
Heating water ⁸⁾	-	≤ +110	X	-	-	-	-	-	-	X	-	-	If used as circulating pump to DIN 4752: p max ≤ 10 bar
Heating water	-	≤ +140	X	-	-	X	X	-	-	-	-	-	
Condensate	-	≤ +110	X	-	-	-	-	-	-	X	-	-	-
Cooling water without antifreeze	-	≤ +60	X	-	-	-	-	-	-	X	-	-	Open circuit: GB 10 required
Cooling water with antifreeze ⁹⁾ , pH ≥ 7.5	≥ -30	≤ +60	X	-	-	-	-	-	-	X	-	-	Open circuit: GB required
Cooling water pH ≥ 7.5 (with antifreeze ⁹⁾)	≥ +60	≤ +110	X	-	-	-	-	X	-	-	-	-	Open circuit: GB required
Slightly contaminated water	-	≤ +60	X	-	-	-	-	-	-	X	-	-	-
Pure water ¹⁰⁾	-	≤ +60	X	-	-	-	-	-	-	-	X	-	-
Raw water	-	≤ +60	X	-	-	-	-	-	-	X	-	-	-
Swimming pool water (fresh water)	-	≤ +60	X	-	-	-	-	-	-	X	-	-	Also applies to requirements as per DIN 19643
Swimming pool water ¹¹⁾ : filtration	-	≤ +40	-	-	X	-	-	-	-	X	-	-	Variant GB Shaft C45+N, shaft sleeve CrNiMo steel, nut A4/AISI 316, key A2, casing wear ring (suction and discharge side) grey cast iron JL 1040/ CI
Swimming pool water ¹¹⁾ : water features; without turbulences and/or air content	-	≤ +40	-	-	X	-	-	-	-	X	-	-	Variant GB Shaft C45+N, shaft sleeve CrNiMo steel, nut A4/ AISI 316, key A2, casing wear ring (suction and discharge side) CC495K-G5
Dam water	-	≤ +60	-	-	X	-	-	-	-	X	-	-	If solids are contained, contact KSB.
Drinking water ¹²⁾	-	≤ +60	-	-	X	-	-	-	-	X	-	-	-
Partly desalinated water	-	≤ +120	X	-	-	-	-	-	-	X	-	-	-
Fully desalinated water as boiler feed water	-	≤ +110	X	-	-	-	-	-	-	X	-	-	-
Refrigerants, cooling brines													
Cooling brine; inorganic, pH > 7.5, inhibited	≥ -30	≤ +25	X	-	-	-	-	-	-	-	X	-	-

⁶⁾ T = fluid temperature

⁷⁾ General evaluation criteria for results of water analysis: pH ≥ 7; chlorides content (Cl) ≤ 250 mg/kg. Chlorine (Cl₂) ≤ 0.6 mg/kg

⁸⁾ Treatment to VdTUV 1466, additional requirement: O₂ t ≤ 0.02 mg/l

⁹⁾ Antifreeze on ethylene glycol basis with inhibitors, content > 20 % to 50 % (e.g. Antifrogen N)

¹⁰⁾ No pure water, electrical conductivity at 25 °C: ≤ 800 µS/cm, neutral with regard to chemical corrosion

¹¹⁾ France: Observe the rules as per ministerial order dated 18 January 2002.

¹²⁾ For France, ACS approval is required.

Fluid handled	T ⁵⁾		Materials			Shaft seal						Comments	
			Casing/impeller			Mechanical seal							
	Minimum	Maximum	Grey cast iron / grey cast iron	Grey cast iron / stainless steel	Grey cast iron / tin bronze	U3BEGG (WE 25, 35)	AQ1EGG (WE 55)	Q1Q1EGG	U3U3VGG	Q1Q1X4GG	BQ1EGG		Q7Q7EGG
Water with antifreeze, pH ≥ 7.5	≥ -30	≤ +60	✗	-	-	-	-	-	-	-	✗	-	-
Water with antifreeze, pH ≥ 7.5	≥ +60	≤ +110	✗	-	-	-	-	✗	-	-	-	-	-
Oils/emulsions													
Drilling emulsion, grinding emulsion	-	≤ +60	✗	-	-	-	-	-	✗	-	-	-	-
Oil-water emulsion	-	≤ +60	✗	-	-	-	-	-	✗	-	-	-	-

Overview of functions

Overview of functions

Functions / firmware	PumpDrive 2	PumpDrive 2 Eco
Protective functions		
Thermal motor protection	X	X
Mains voltage monitoring	X	X
Phase failure, motor side	X	X
Short-circuit monitoring, motor side (phase to phase and phase to earth)	X	X
Dynamic overload protection by speed limitation (i ² t control)	X	X
Resonant frequency suppression	X	X
Broken wire detection (live zero)	X	X
Protection against dry running and hydraulic blockage (sensorless due to learning function)	X	X
Dry running protection (external control signal)	X	X
Operating point estimation and characteristic curve control	X	X
Open-loop control		
Open-loop control mode	X	X
Closed-loop control		
Closed-loop control mode via integrated PID controller	X	X
Pressure control / differential pressure control (Δp const)	X	X
Pressure control / differential pressure control with dynamic pressure compensation (Δp var)	X	X
Flow rate control	X	X
Sensorless differential pressure control (Δp const) in a single-pump configuration	X	X
Sensorless differential pressure control with dynamic pressure compensation (Δp var) in a single-pump configuration	X	X
Sensorless flow rate control	X	X
Level control	X	X
Temperature control	X	X
Alternative setpoint	X	-
Operation and monitoring (display)		
Measured value display (pressure, head, speed, electric power, motor voltage, motor current, torque)	X	X
Fault history	X	X
Operating hours counter	X	X
Fault reporting via relay	X	X
Frequency inverter functions		
Programmable start ramps and stop ramps	X	X
Field-oriented control (vector control), V/f control	X	X
Configurable motor control method (asynchronous motor, KSB SuPremE)	X	X
Automatic motor adaptation (AMA)	X	X
Motor standstill heater	X	X
Manual-0-automatic mode	X	X
External OFF	X	X
External minimum speed	X	X
Sleep mode (stand-by mode)	X	X
Energy savings meter	X	-
Pump functions		
Flow rate estimation	X	X
M12 module with PumpMeter bus connection	X	X
M12 module for dual-pump configuration	X	X
M12 module for multiple pump configuration with up to 6 pumps	X	X
Functional check run	X	X
Deragging	X	X
Integrated dual-pump configuration (1x100 % with redundant pump or 2x50 % without redundant pump)	X	X
Multiple pump configuration with up to 6 pumps	X	X
Waste water function: start-up at maximum speed	X	-
Waste water function: rinsing function	X	-
Operation		

Functions / firmware	PumpDrive 2	PumpDrive 2 Eco
Control panel	X	X ¹³⁾
Commissioning wizard	X	X ¹⁴⁾
Favourites list	X	-
Service interface	X	X

Pressure limits and temperature limits

Test pressure limits and temperature limits

Pressure limits and temperature limits as a function of material variant

Material variant	Fluid temperature ¹⁵⁾¹⁶⁾	Test pressure ¹⁷⁾
	[°C]	[bar]
GG, GC, GB	-30 to +140	≤ 21

In-service pressure limits and temperature limits

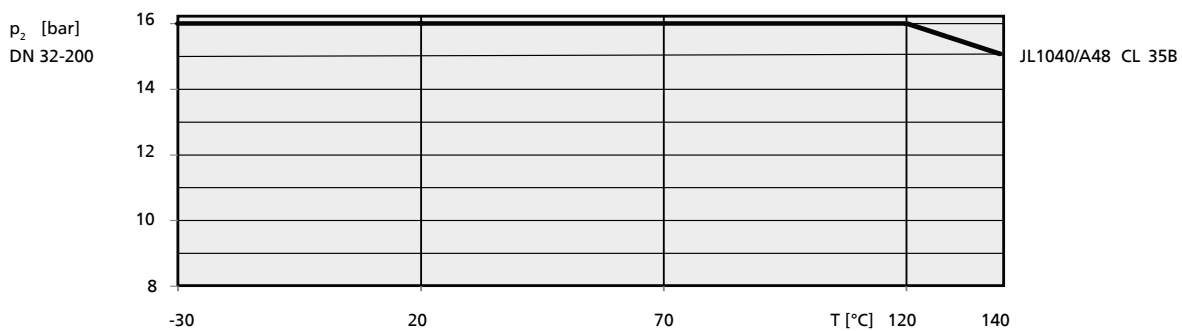

Fig. 1: Operating pressure limits and temperature limits

¹³ Some functions can only be parameterised and/or displayed using the KSB ServiceTool (see operating manual).

¹⁴ Only available via KSB ServiceTool or app

¹⁵ For hot water heating systems to DIN 4752, Section 4.5, application limits must be observed.

¹⁶ For fluid temperatures >140 °C use Etanorm SYT.

¹⁷ The casing components have been checked for leakage by means of internal pressure tests to ZN 1650 with water.

Technical data
Pump

Technical data of the pump

Etaline Z	Shaft unit	Impeller				Speed limit	
		Impeller outlet width	Impeller inlet diameter	Nominal impeller diameter		Minimum	Maximum
				Minimum	Maximum		
[mm]						[rpm]	
032-032-160	WS_25	5,7	52,7	112	170	800	2100
032-032-200	WS_25	5,6	54,0	165	204	800	2100
040-040-160	WS_25	8,5	60,6	136	174	800	1800
040-040-250	WS_25	7,5	62,6	197	261	800	2000
050-050-160	WS_25	13,0	70,0	120	174	800	2100
050-050-250	WS_25	8,4	74,1	198	260	800	2100
065-065-160	WS_25	16,9	86,9	108	174	800	1900
065-065-250	WS_25	10,5	84,0	196	260	800	1800
080-080-160	WS_25	21,0	92,0	132	174	800	2000
080-080-250	WS_35	15,1	101,0	190	260	800	1800
100-100-200	WS_35	24,5	115,0	178	219	800	2100
100-100-250	WS_35	19,0	115,0	215	269	800	2000
125-125-200	WS_35	32,5	142,0	179	219	800	2000
125-125-250	WS_35	27,0	145,0	210	269	800	1750
150-150-250	WS_35	37,0	162,4	218	269	800	2000
200-200-250	WS_35	48,8	191,0	220	269	800	1700
200-200-315	WS_55	39,7	191,5	264	334	800	1500

Motor (fixed speed version), n = 1450 rpm

50 Hz, technical data of the motor, n = 1450 rpm (fixed speed version)

Etaline Z	Efficiency class	P _N [kW]	I _N	Motor	[kg]
			3~400 V [A]		
n = 1450 rpm					
032-032-160	IE1	0,25	0,77	071M	62,7
032-032-160	IE1	0,37	1,06	071M	65,1
032-032-160	IE1	0,55	1,46	080M	71,9
032-032-160	IE1	0,75	1,66	080M	74,7
032-032-160	IE3	1,10	2,28	090S	80,5
032-032-160	IE3	1,50	2,99	090L	87,1
032-032-200	IE1	0,55	1,46	080M	92,7
032-032-200	IE1	0,75	1,66	080M	95,5
032-032-200	IE3	1,10	2,28	090S	101,4
032-032-200	IE3	1,50	2,99	090L	108
032-032-200	IE3	2,20	4,18	100L	123,5
032-032-200	IE3	3,00	6,21	100L	127,5
032-032-200	IE3	4,00	8,32	112M	137,5
040-040-160	IE1	0,25	0,77	071M	64,2
040-040-160	IE1	0,37	1,06	071M	66,6
040-040-160	IE1	0,55	1,46	080M	73,4
040-040-160	IE1	0,75	1,66	080M	76,2
040-040-160	IE3	1,10	2,28	090S	82
040-040-160	IE3	1,50	2,99	090L	88,6
040-040-250	IE1	0,55	1,46	080M	108,8
040-040-250	IE1	0,75	1,66	080M	114,7
040-040-250	IE3	1,10	2,28	090S	120,6
040-040-250	IE3	1,50	2,99	090L	127,2
040-040-250	IE3	2,20	4,18	100L	142,7
040-040-250	IE3	3,00	6,21	100L	146,7
040-040-250	IE3	4,00	8,32	112M	156,7
040-040-250	IE3	5,50	11,05	132S	181,5
040-040-250	IE3	7,50	15,05	132M	209,5
050-050-160	IE1	0,25	0,77	071M	66,1
050-050-160	IE1	0,37	1,06	071M	72,8
050-050-160	IE1	0,55	1,46	080M	79,5
050-050-160	IE1	0,75	1,66	080M	82,3
050-050-160	IE3	1,10	2,28	090S	88,2
050-050-160	IE3	1,50	2,99	090L	94,8
050-050-160	IE3	2,20	4,18	100L	110,3
050-050-160	IE3	3,00	6,21	100L	114,3
050-050-160	IE3	4,00	8,32	112M	124,3
050-050-250	IE3	1,10	2,28	090S	123,5
050-050-250	IE3	1,50	2,99	090L	130,1
050-050-250	IE3	2,20	4,18	100L	145,6
050-050-250	IE3	3,00	6,21	100L	149,6
050-050-250	IE3	4,00	8,32	112M	159,6
050-050-250	IE3	5,50	11,05	132S	184,4
050-050-250	IE3	7,50	15,05	132M	212,4
050-050-250	IE3	11,00	21,58	160M	264,8
065-065-160	IE1	0,25	0,77	071M	73,7
065-065-160	IE1	0,37	1,06	071M	80,4
065-065-160	IE1	0,55	1,46	080M	87,1
065-065-160	IE1	0,75	1,66	080M	89,9
065-065-160	IE3	1,10	2,28	090S	95,8
065-065-160	IE3	1,50	2,99	090L	102,4
065-065-160	IE3	2,20	4,18	100L	117,9
065-065-160	IE3	3,00	6,21	100L	121,9
065-065-160	IE3	4,00	8,32	112M	131,9

Etaline Z	Efficiency class	P _N	I _N	Motor	[kg]
			3~400 V		
n = 1450 rpm		[kW]	[A]		
065-065-250	IE3	1,50	2,99	090L	143,4
065-065-250	IE3	2,20	4,18	100L	158,9
065-065-250	IE3	3,00	6,21	100L	162,9
065-065-250	IE3	4,00	8,32	112M	172,9
065-065-250	IE3	5,50	11,05	132S	197,7
065-065-250	IE3	7,50	15,05	132M	225,7
080-080-160	IE1	0,55	1,46	080M	91,8
080-080-160	IE1	0,75	1,66	080M	97,7
080-080-160	IE3	1,10	2,28	090S	103,6
080-080-160	IE3	1,50	2,99	090L	110,2
080-080-160	IE3	2,20	4,18	100L	125,6
080-080-160	IE3	3,00	6,21	100L	129,6
080-080-160	IE3	4,00	8,32	112M	139,6
080-080-160	IE3	5,50	11,05	132S	164,5
080-080-250	IE3	2,20	4,18	100L	184,7
080-080-250	IE3	3,00	6,21	100L	188,7
080-080-250	IE3	4,00	8,32	112M	198,7
080-080-250	IE3	5,50	11,05	132S	222,5
080-080-250	IE3	7,50	15,05	132M	250,5
080-080-250	IE3	11,00	21,58	160M	278,5
100-100-200	IE3	2,20	4,18	100L	218,1
100-100-200	IE3	3,00	6,21	100L	222,1
100-100-200	IE3	4,00	8,32	112M	232,1
100-100-200	IE3	5,50	11,05	132S	255,9
100-100-200	IE3	7,50	15,05	132M	283,9
100-100-200	IE3	11,00	21,58	160M	336,3
100-100-200	IE3	15,00	30,00	160L	368,3
100-100-200	IE3	18,50	37,37	180M	517,5
100-100-250	IE3	4,00	8,32	112M	260,9
100-100-250	IE3	5,50	11,05	132S	284,7
100-100-250	IE3	7,50	15,05	132M	312,7
100-100-250	IE3	11,00	21,58	160M	365,1
100-100-250	IE3	15,00	30,00	160L	397,1
100-100-250	IE3	18,50	37,37	180M	546,4
100-100-250	IE3	22,00	43,68	180L	576,4
100-100-250	IE3	30,00	56,84	200L	705
125-125-200	IE3	2,20	4,18	100L	234,6
125-125-200	IE3	3,00	6,21	100L	238,6
125-125-200	IE3	4,00	8,32	112M	248,6
125-125-200	IE3	5,50	11,05	132S	272,4
125-125-200	IE3	7,50	15,05	132M	300,4
125-125-200	IE3	11,00	21,58	160M	352,8
125-125-200	IE3	15,00	30,00	160L	384,8
125-125-200	IE3	18,50	37,37	180M	534
125-125-200	IE3	22,00	43,68	180L	564
125-125-250	IE3	4,00	8,32	112M	277,8
125-125-250	IE3	5,50	11,05	132S	301,6
125-125-250	IE3	7,50	15,05	132M	329,6
125-125-250	IE3	11,00	21,58	160M	382
125-125-250	IE3	15,00	30,00	160L	414
125-125-250	IE3	18,50	37,37	180M	563,2
125-125-250	IE3	22,00	43,68	180L	593,2
150-150-250	IE3	7,50	15,05	132M	391,5
150-150-250	IE3	11,00	21,58	160M	444
150-150-250	IE3	15,00	30,00	160L	476
150-150-250	IE3	18,50	37,37	180M	625,2
150-150-250	IE3	22,00	43,68	180L	655,2

Etaline Z	Efficiency class	P _N	I _N	Motor	[kg]
			3~400 V		
n = 1450 rpm		[kW]	[A]		
150-150-250	IE3	30,00	56,84	200L	783,8
150-150-250	IE3	37,00	69,47	225S	916,6
150-150-250	IE3	45,00	84,21	225M	976,6
200-200-250	IE3	11,00	21,58	160M	565,8
200-200-250	IE3	15,00	30,00	160L	597,8
200-200-250	IE3	18,50	37,37	180M	747
200-200-250	IE3	22,00	43,68	180L	777
200-200-250	IE3	30,00	56,84	200L	905,6
200-200-250	IE3	37,00	69,47	225S	1038,4
200-200-250	IE3	45,00	84,21	225M	1098,4
200-200-315	IE3	30,00	56,84	200L	997,1
200-200-315	IE3	37,00	69,47	225S	1129,6
200-200-315	IE3	45,00	84,21	225M	1189,6
200-200-315	IE3	55,00	101,05	250M	1416,4

Motor (variable speed version), n = 1500 rpm

50 Hz, technical data of the motor, n = 1500 rpm (variable speed version)

Etaline Z PumpDrive 2 n = 1500 rpm	Efficiency class	P _N [kW]	I _N 3~400 V [A]	Motor	[kg]
032-032-160	IE5	0,55	1,6	080M	81,9
032-032-160	IE5	0,75	2,1	080M	84,7
032-032-160	IE5	1,10	3,0	090S	90,5
032-032-160	IE5	1,50	4,0	090L	97,1
032-032-200	IE5	0,55	1,6	080M	102,7
032-032-200	IE5	0,75	2,1	080M	105,5
032-032-200	IE5	1,10	3,0	090S	111,4
032-032-200	IE5	1,50	4,0	090L	118
032-032-200	IE5	2,20	5,7	100L	136,5
032-032-200	IE5	3,00	7,8	100L	140,5
032-032-200	IE5	4,00	9,6	112M	150,5
040-040-160	IE5	0,55	1,6	080M	83,4
040-040-160	IE5	0,75	2,1	080M	86,2
040-040-160	IE5	1,10	3,0	090S	92
040-040-160	IE5	1,50	4,0	090L	98,6
040-040-250	IE5	0,55	1,6	080M	118,8
040-040-250	IE5	0,75	2,1	080M	124,7
040-040-250	IE5	1,10	3,0	090S	130,6
040-040-250	IE5	1,50	4,0	090L	137,2
040-040-250	IE5	2,20	5,7	100L	155,7
040-040-250	IE5	3,00	7,8	100L	159,7
040-040-250	IE5	4,00	9,6	112M	169,7
040-040-250	IE5	5,50	13,5	132S	206,7
040-040-250	IE5	7,50	17,6	132M	234,7
050-050-160	IE5	0,55	1,6	080M	89,5
050-050-160	IE5	0,75	2,1	080M	92,3
050-050-160	IE5	1,10	3,0	090S	98,2
050-050-160	IE5	1,50	4,0	090L	104,8
050-050-160	IE5	2,20	5,7	100L	123,3
050-050-160	IE5	3,00	7,8	100L	127,3
050-050-160	IE5	4,00	9,6	112M	137,3
050-050-250	IE5	1,10	3,0	090S	133,5
050-050-250	IE5	1,50	4,0	090L	140,1
050-050-250	IE5	2,20	5,7	100L	158,6
050-050-250	IE5	3,00	7,8	100L	162,6
050-050-250	IE5	4,00	9,6	112M	172,6
050-050-250	IE5	5,50	13,5	132S	209,6
050-050-250	IE5	7,50	17,6	132M	237,6
050-050-250	IE5	11,00	24,2	160M	290
065-065-160	IE5	0,55	1,6	080M	97,1
065-065-160	IE5	0,75	2,1	080M	99,9
065-065-160	IE5	1,10	3,0	090S	105,8
065-065-160	IE5	1,50	4,0	090L	112,4
065-065-160	IE5	2,20	5,7	100L	130,9
065-065-160	IE5	3,00	7,8	100L	134,9
065-065-160	IE5	4,00	9,6	112M	144,9
065-065-250	IE5	1,50	4,0	090L	153,4
065-065-250	IE5	2,20	5,7	100L	171,9
065-065-250	IE5	3,00	7,8	100L	175,9
065-065-250	IE5	4,00	9,6	112M	185,9
065-065-250	IE5	5,50	13,5	132S	222,9
065-065-250	IE5	7,50	17,6	132M	250,9
080-080-160	IE5	0,55	1,6	080M	101,8
080-080-160	IE5	0,75	2,1	080M	107,7

Etaline Z PumpDrive 2 n = 1500 rpm	Efficiency class	P _N [kW]	I _N 3~400 V [A]	Motor	[kg]
080-080-160	IE5	1,10	3,0	090S	113,6
080-080-160	IE5	1,50	4,0	090L	120,2
080-080-160	IE5	2,20	5,7	100L	138,6
080-080-160	IE5	3,00	7,8	100L	142,6
080-080-160	IE5	4,00	9,6	112M	152,6
080-080-160	IE5	5,50	13,5	132S	189,7
080-080-250	IE5	2,20	5,7	100L	197,7
080-080-250	IE5	3,00	7,8	100L	201,7
080-080-250	IE5	4,00	9,6	112M	211,7
080-080-250	IE5	5,50	13,5	132S	247,7
080-080-250	IE5	7,50	17,6	132M	275,7
100-100-200	IE5	2,20	5,7	100L	231,1
100-100-200	IE5	3,00	7,8	100L	235,1
100-100-200	IE5	4,00	9,6	112M	245,1
100-100-200	IE5	5,50	13,5	132S	281,1
100-100-200	IE5	7,50	17,6	132M	309,1
100-100-200	IE5	11,00	24,2	160M	361,5
100-100-200	IE5	15,00	33,0	160L	423,5
100-100-200	IE4	18,50	42,0	180M	589,5
100-100-250	IE5	4,00	9,6	112M	273,9
100-100-250	IE5	5,50	13,5	132S	309,9
100-100-250	IE5	7,50	17,6	132M	337,9
100-100-250	IE5	11,00	24,2	160M	390,3
100-100-250	IE5	15,00	33,0	160L	452,3
100-100-250	IE4	18,50	42,0	180M	618,4
100-100-250	IE4	22,00	48,5	180L	648,4
100-100-250	IE4	30,00	65,4	200L	777
125-125-200	IE5	2,20	5,7	100L	247,6
125-125-200	IE5	3,00	7,8	100L	251,6
125-125-200	IE5	4,00	9,6	112M	261,6
125-125-200	IE5	5,50	13,5	132S	297,6
125-125-200	IE5	7,50	17,6	132M	325,6
125-125-200	IE5	11,00	24,2	160M	378
125-125-200	IE5	15,00	33,0	160L	440
125-125-200	IE4	18,50	42,0	180M	606
125-125-200	IE4	22,00	48,5	180L	636
125-125-250	IE5	4,00	9,6	112M	290,8
125-125-250	IE5	5,50	13,5	132S	326,8
125-125-250	IE5	7,50	17,6	132M	354,8
125-125-250	IE5	11,00	24,2	160M	407,2
125-125-250	IE5	15,00	33,0	160L	469,2
125-125-250	IE4	18,50	42,0	180M	635,2
125-125-250	IE4	22,00	48,5	180L	665,2
150-150-250	IE5	7,50	17,6	132M	416,7
150-150-250	IE5	11,00	24,2	160M	469,2
150-150-250	IE5	15,00	33,0	160L	531,2
150-150-250	IE4	18,50	42,0	180M	697,2
150-150-250	IE4	22,00	48,5	180L	727,2
150-150-250	IE4	30,00	65,4	200L	855,8
150-150-250	IE4	37,00	80,9	225S	1031,8
150-150-250	IE4	45,00	99,3	225M	1096,6
200-200-250	IE5	11,00	24,2	160M	591
200-200-250	IE5	15,00	33,0	160L	653
200-200-250	IE4	18,50	42,0	180M	819
200-200-250	IE4	22,00	48,5	180L	849
200-200-250	IE4	30,00	65,4	200L	977,6
200-200-250	IE4	37,00	80,9	225S	1153,6

Etaline Z PumpDrive 2 n = 1500 rpm	Efficiency class	P _N [kW]	I _N 3~400 V	Motor	[kg]
			[A]		
200-200-250	IE4	45,00	99,3	225M	1218,4
200-200-315	IE4	30,00	65,4	200L	1069,1
200-200-315	IE4	37,00	80,9	225S	1244,8
200-200-315	IE4	45,00	99,3	225M	1309,6

Selection charts

Etaline Z (fixed speed version, single-pump operation), n = 1450 rpm

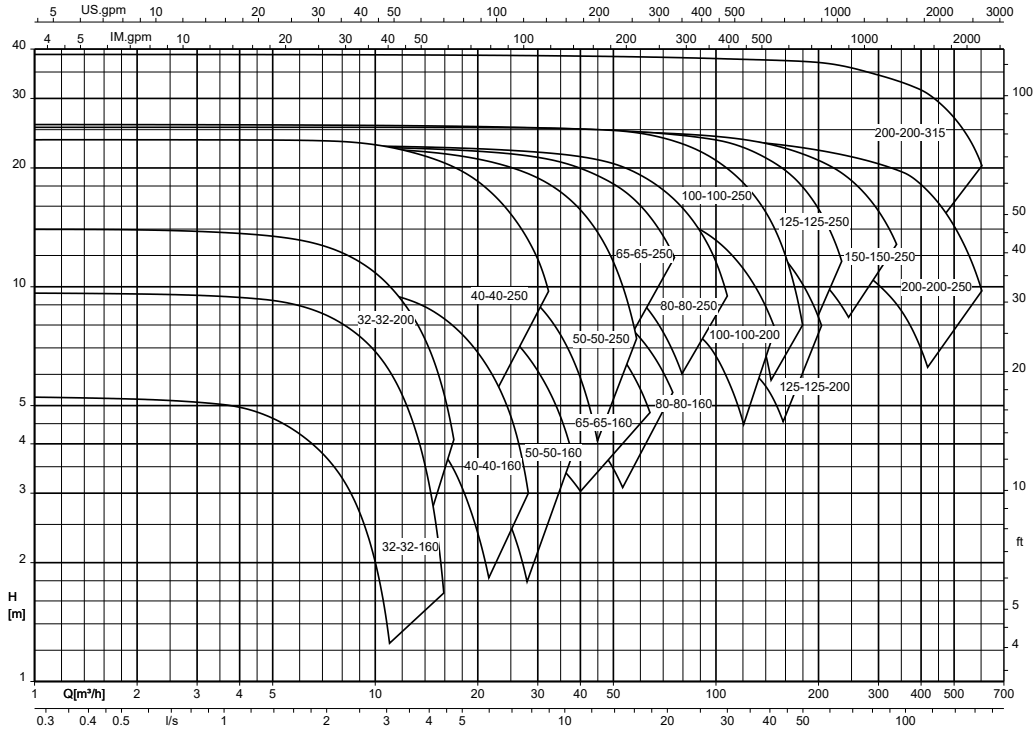

Etaline Z (fixed speed version, parallel operation), n = 1450 rpm

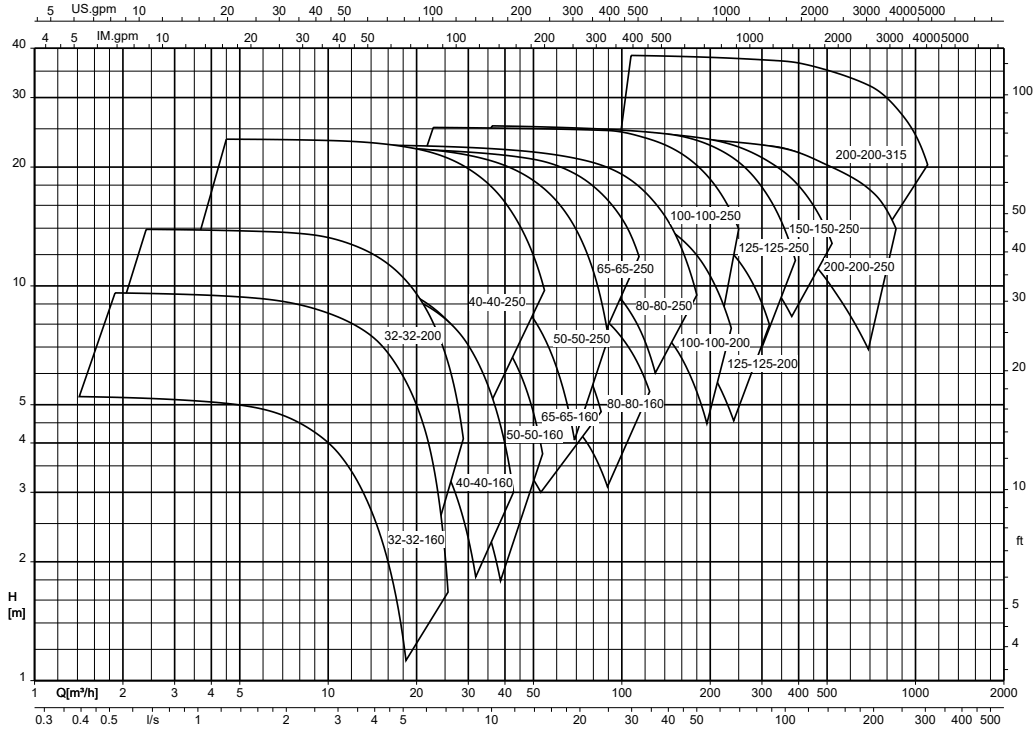

Characteristic curves

General

Test class

Characteristic curves to ISO 9906 Class 3B

NPSH values

The NPSH values indicated in the characteristic curves correspond to a head drop of 3 %.

NPSH values in part-load conditions

NPSH values for flow rates below $Q = 0.3 \times Q_{\text{BEP}}$ can only be measured with intense technical efforts. Evidence of NPSH values in the part-load range cannot be provided.

Density of the fluid handled

The indicated heads and performance data apply to pumped fluids with a density $\rho = 1.0 \text{ kg/dm}^3$ and a kinematic viscosity of up to $20 \text{ mm}^2/\text{s}$ max. If the density $\neq 1.0$, the performance data must be multiplied by ρ . For a viscosity $> 20 \text{ mm}^2/\text{s}$ the corresponding data for cold water has to be calculated and the impact on the pump's performance has to be determined.

Correction factors

The characteristic curves apply to pumps with cast iron or bronze impellers. When using an impeller made of cast steel materials the efficiency and pump power of the corresponding pump sizes have to be multiplied by the correction factors indicated in the characteristic curves.

Etaline Z (fixed speed version), n = 1450 rpm

Etaline Z 032-032-160, n = 1450 rpm

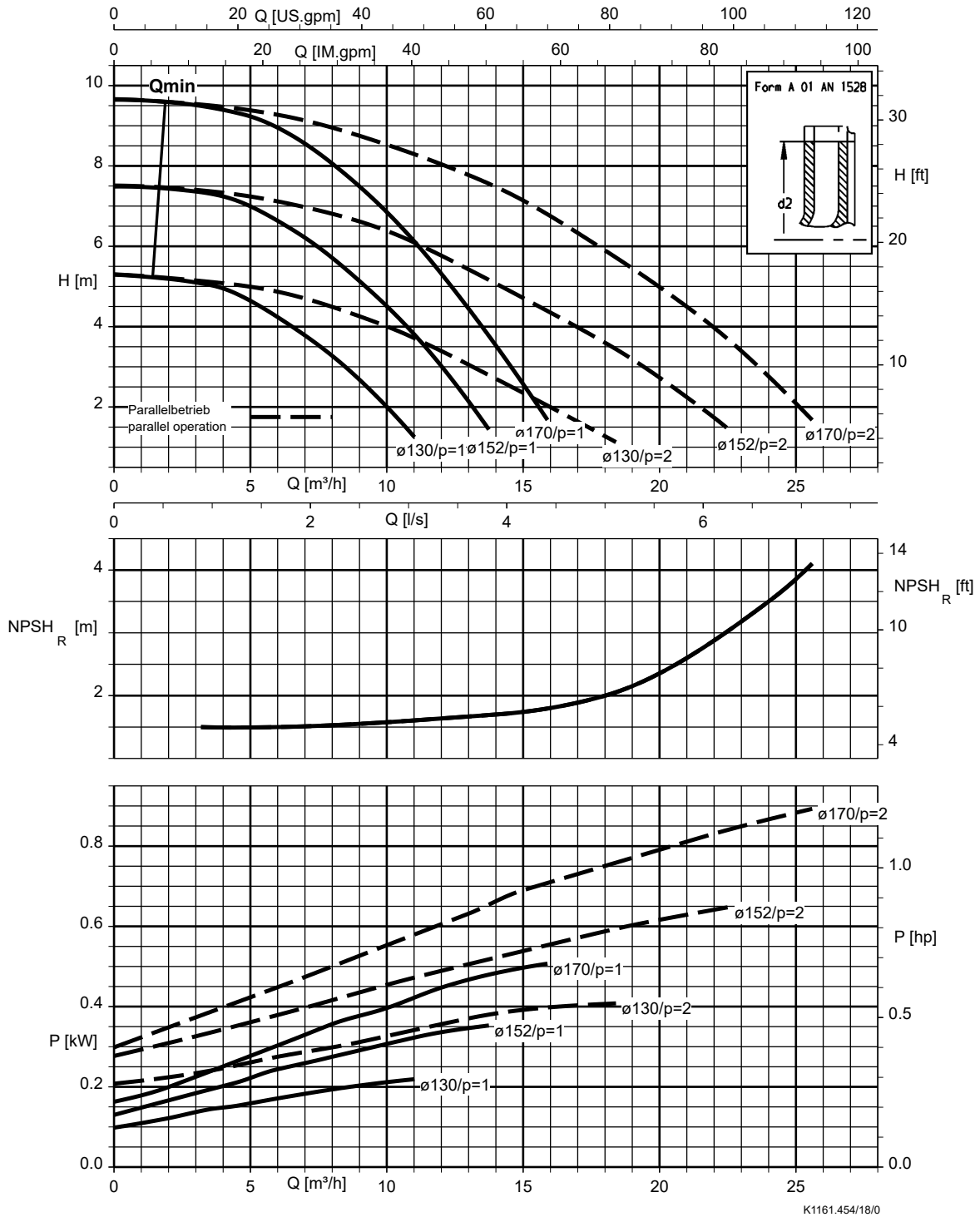

Etaline Z 040-040-160, n = 1450 rpm

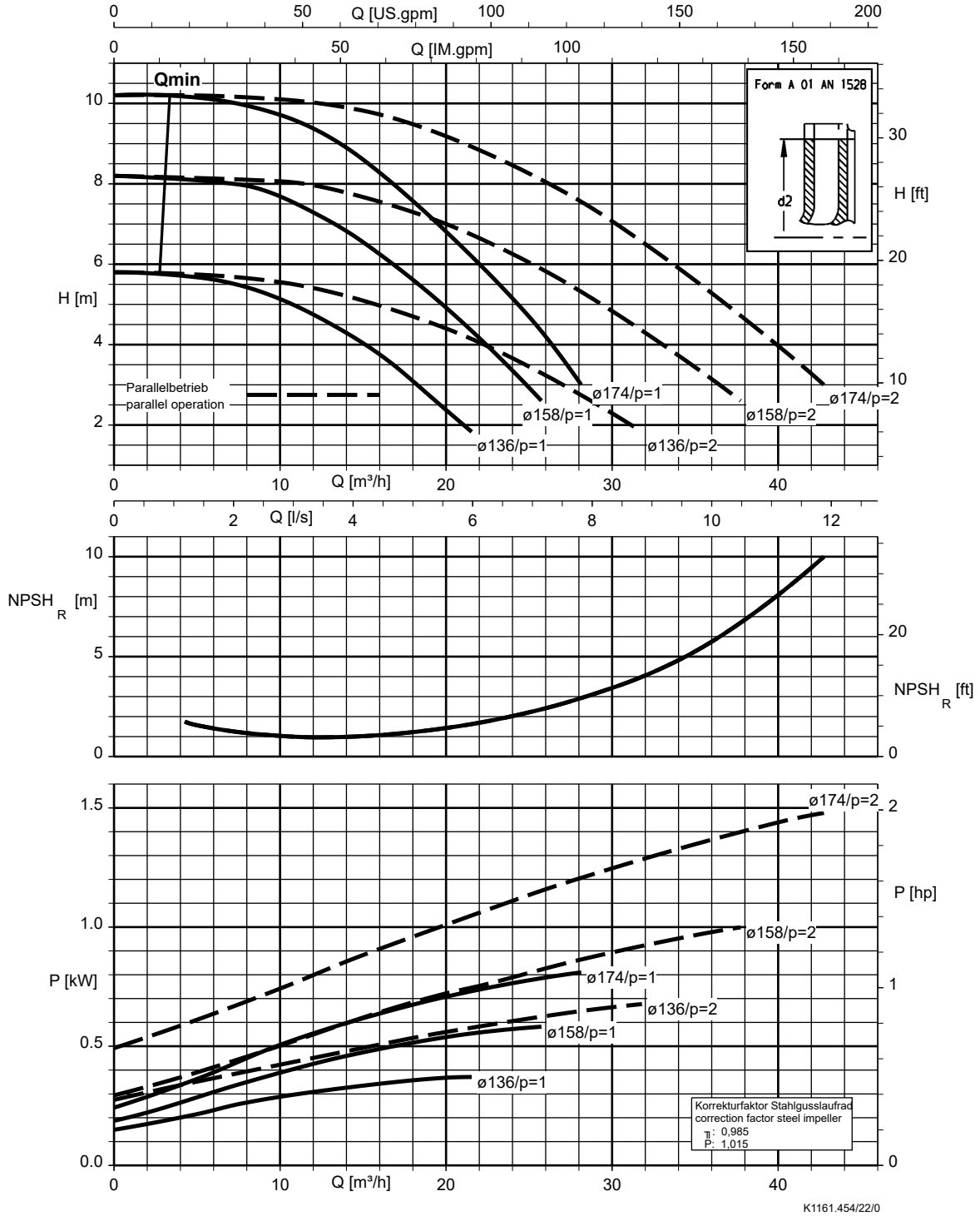

Etaline Z 040-040-250, n = 1450 rpm

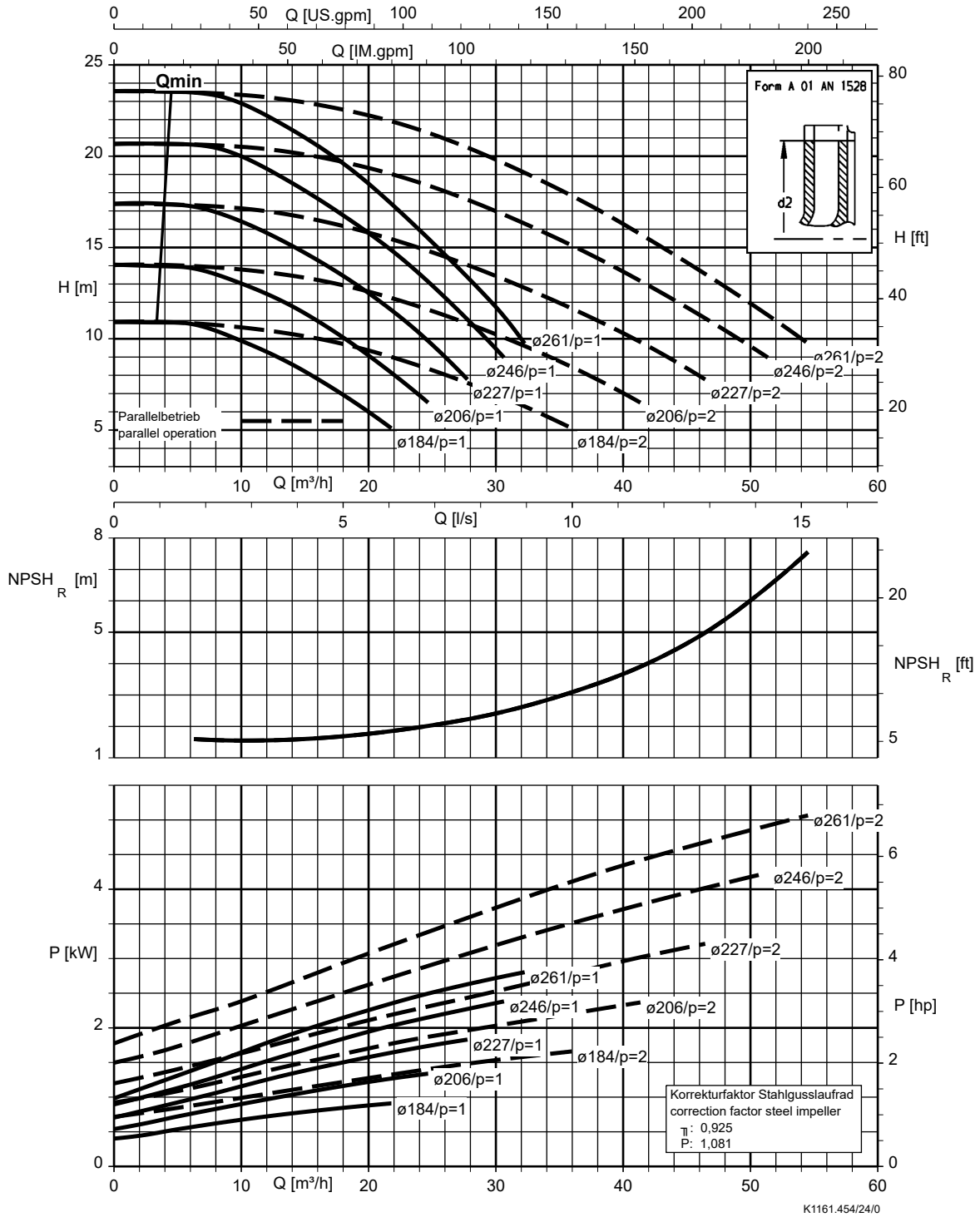

Etaline Z 050-050-160, n = 1450 rpm

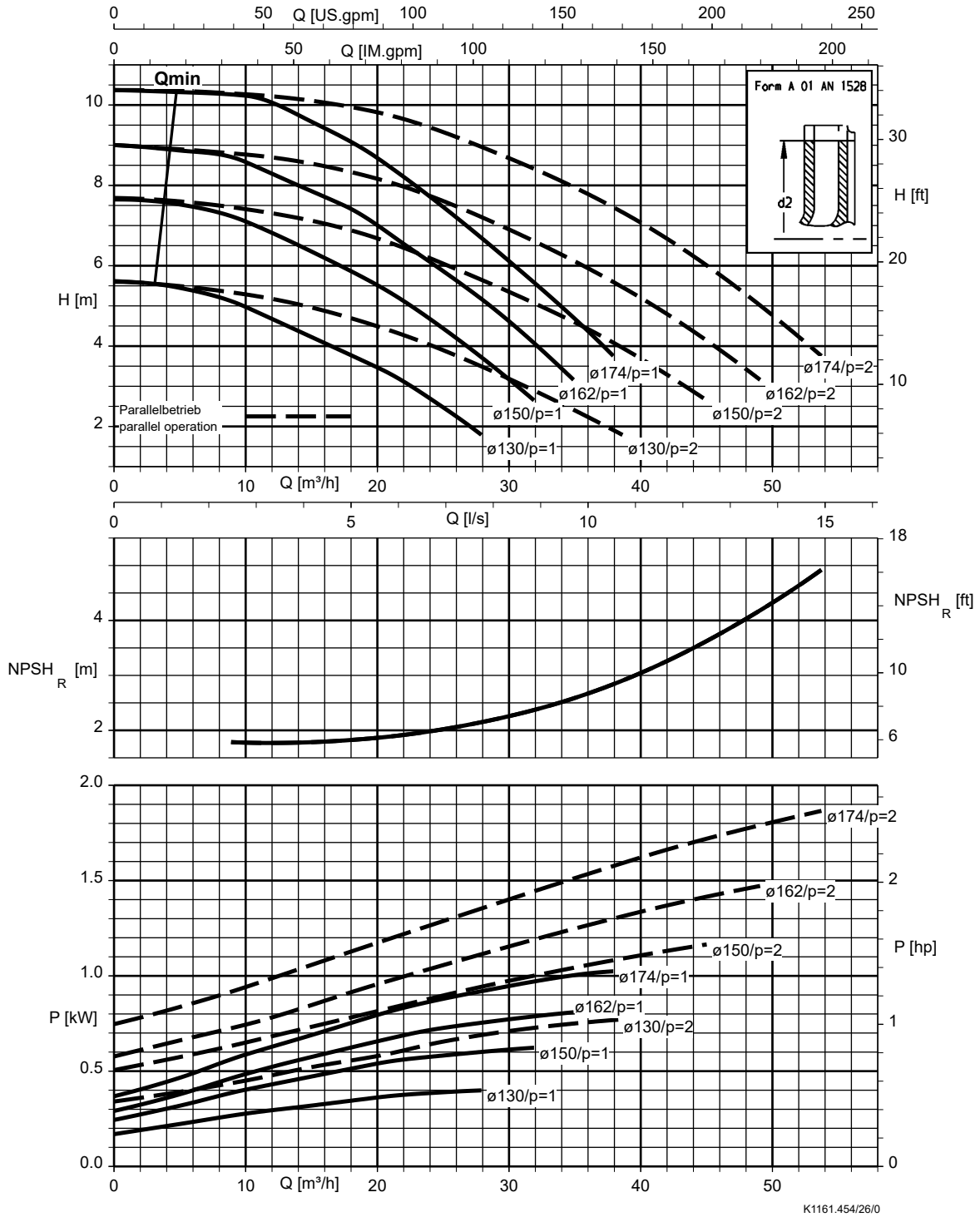

Etaline Z 050-050-250, n = 1450 rpm

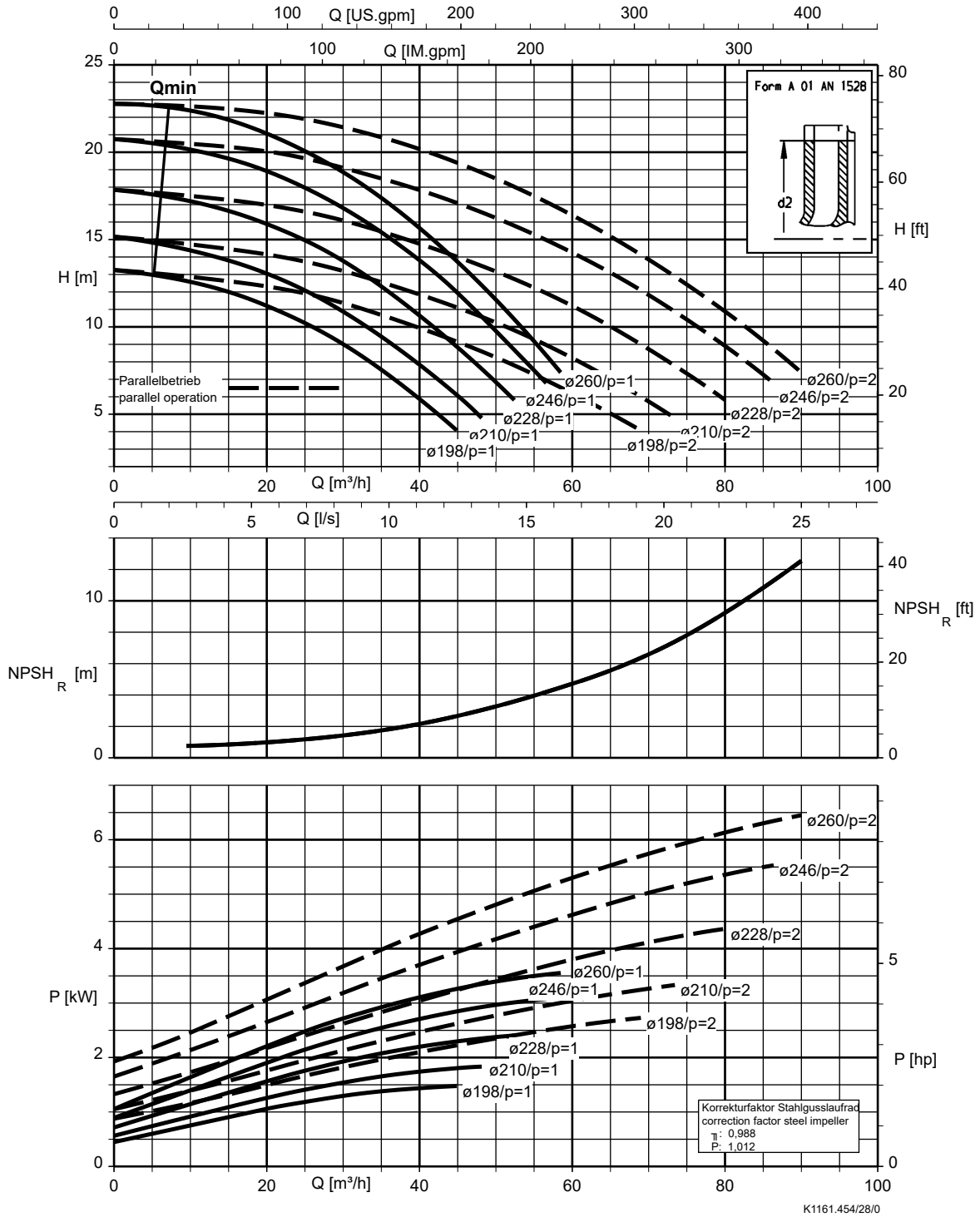

Etaline Z 065-065-160, n = 1450 rpm

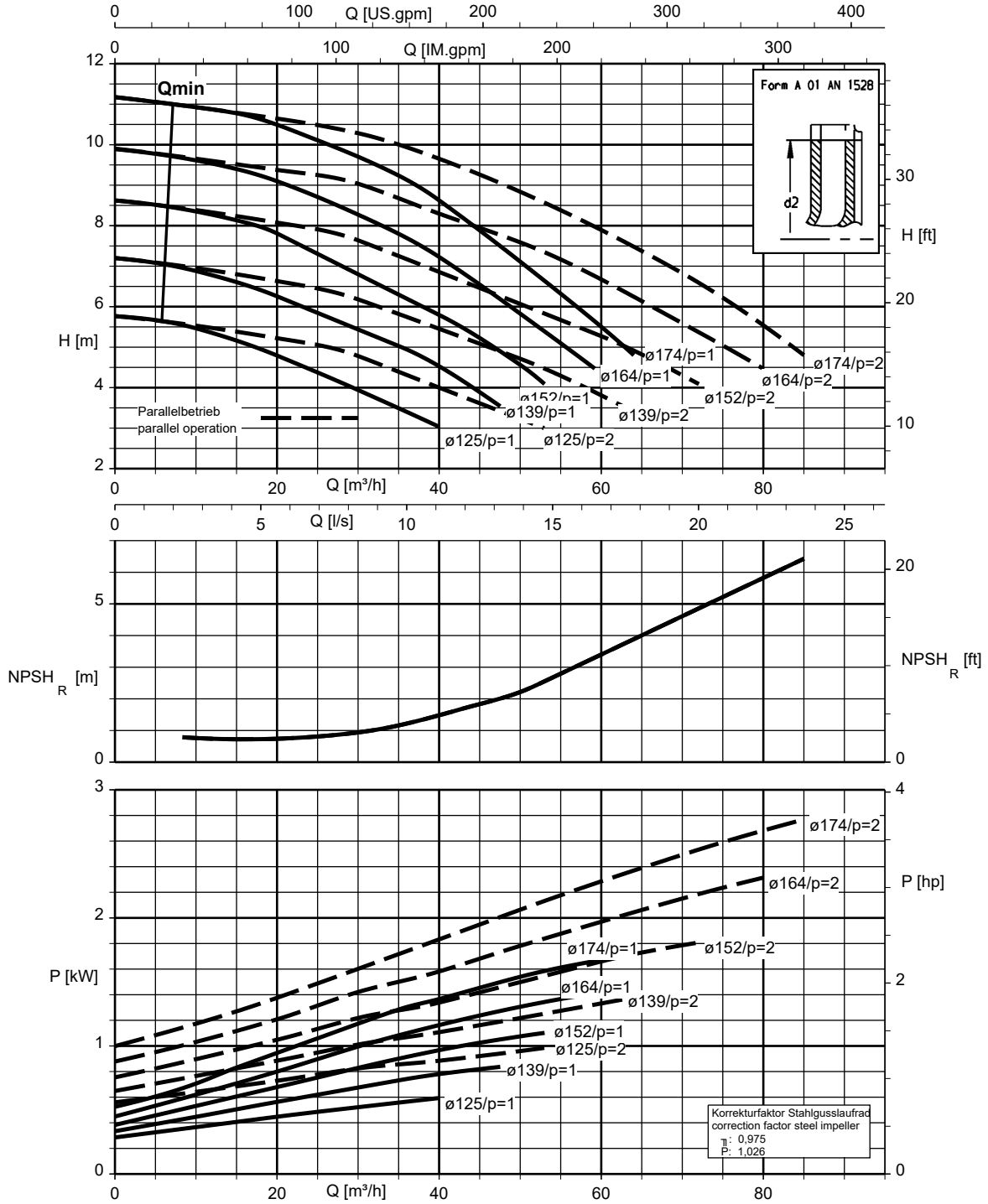

K1161.454/31/0

Etaline Z 065-065-250, n = 1450 rpm

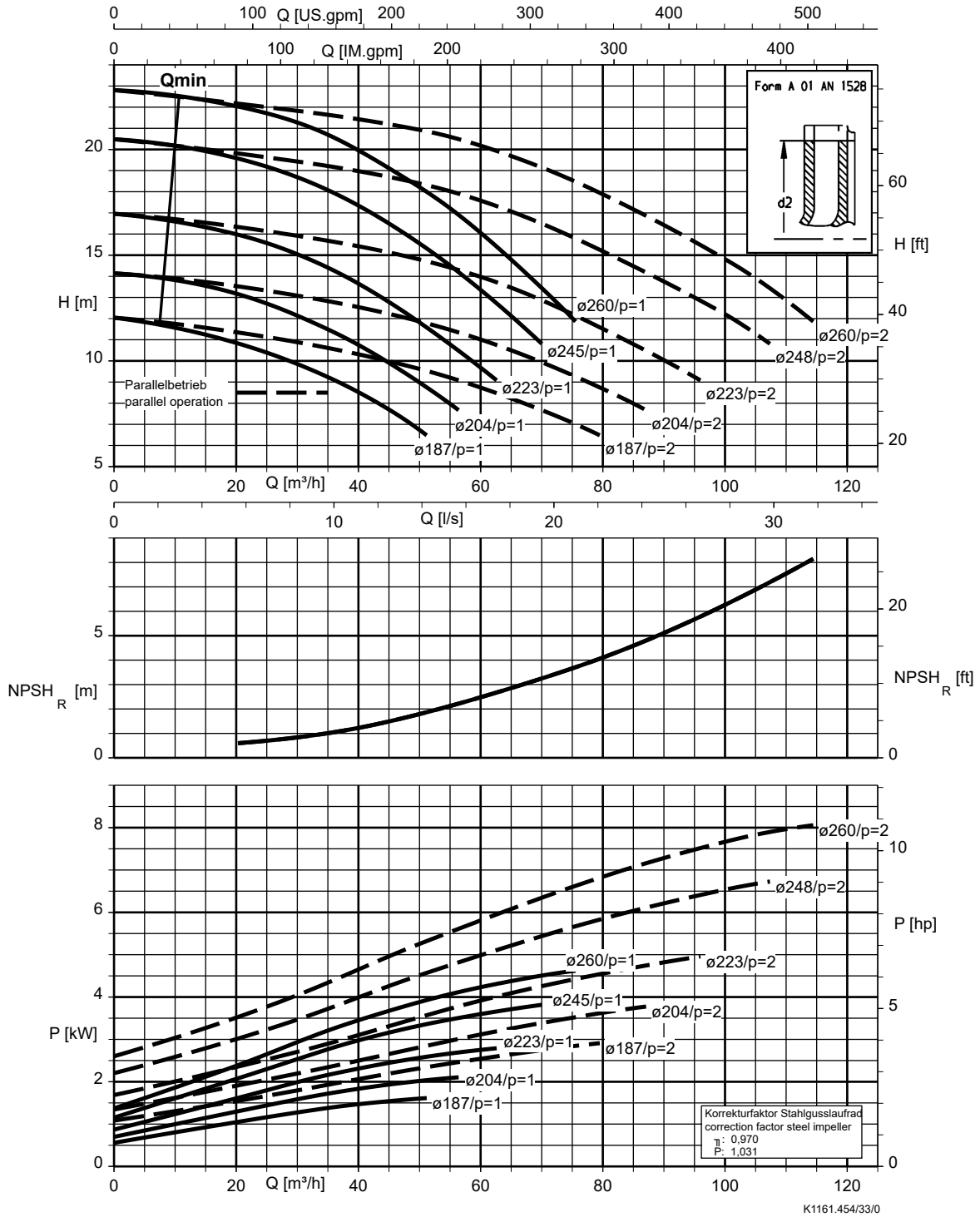

Etaline Z 080-080-160, n = 1450 rpm

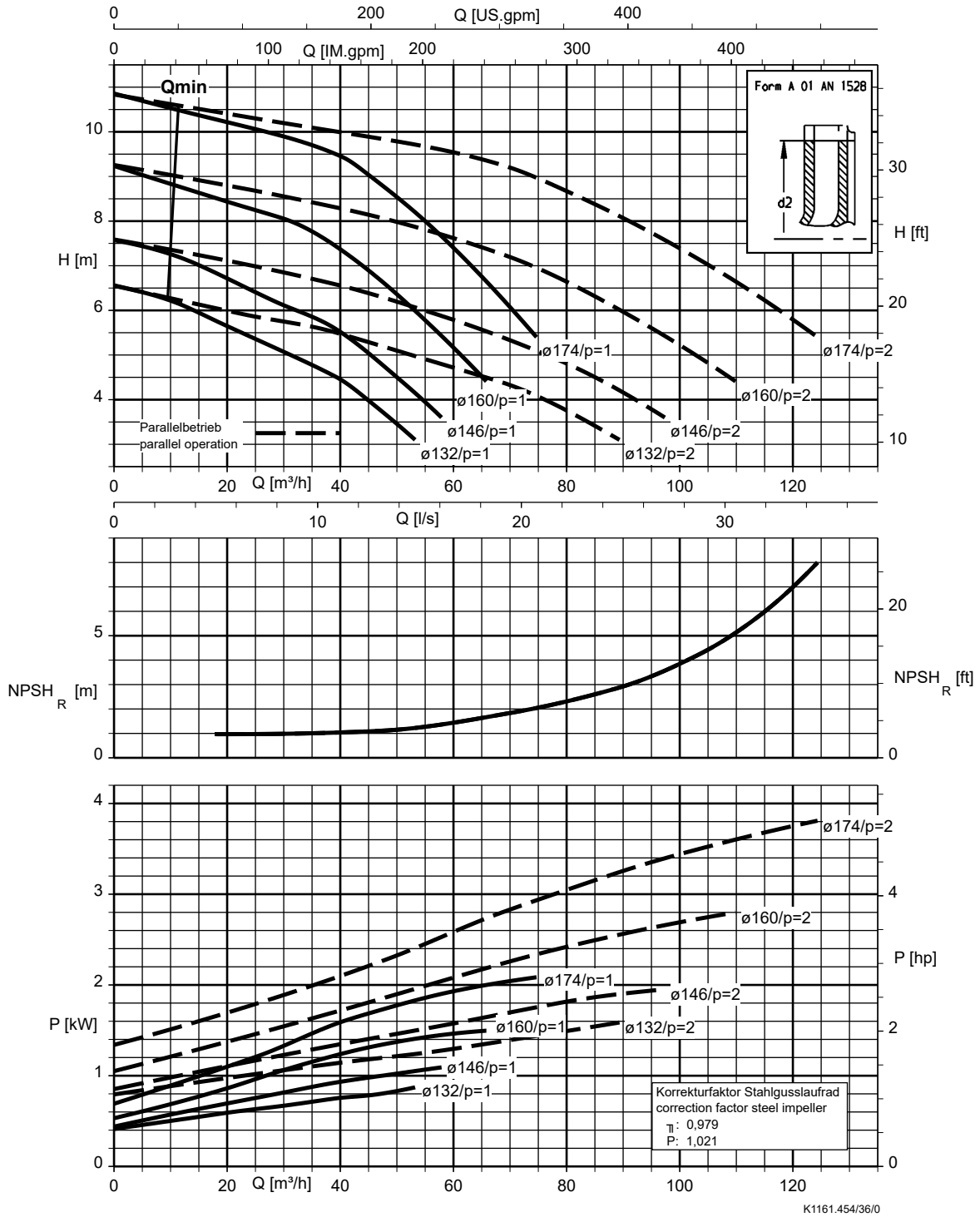

Etaline Z 080-080-250, n = 1450 rpm

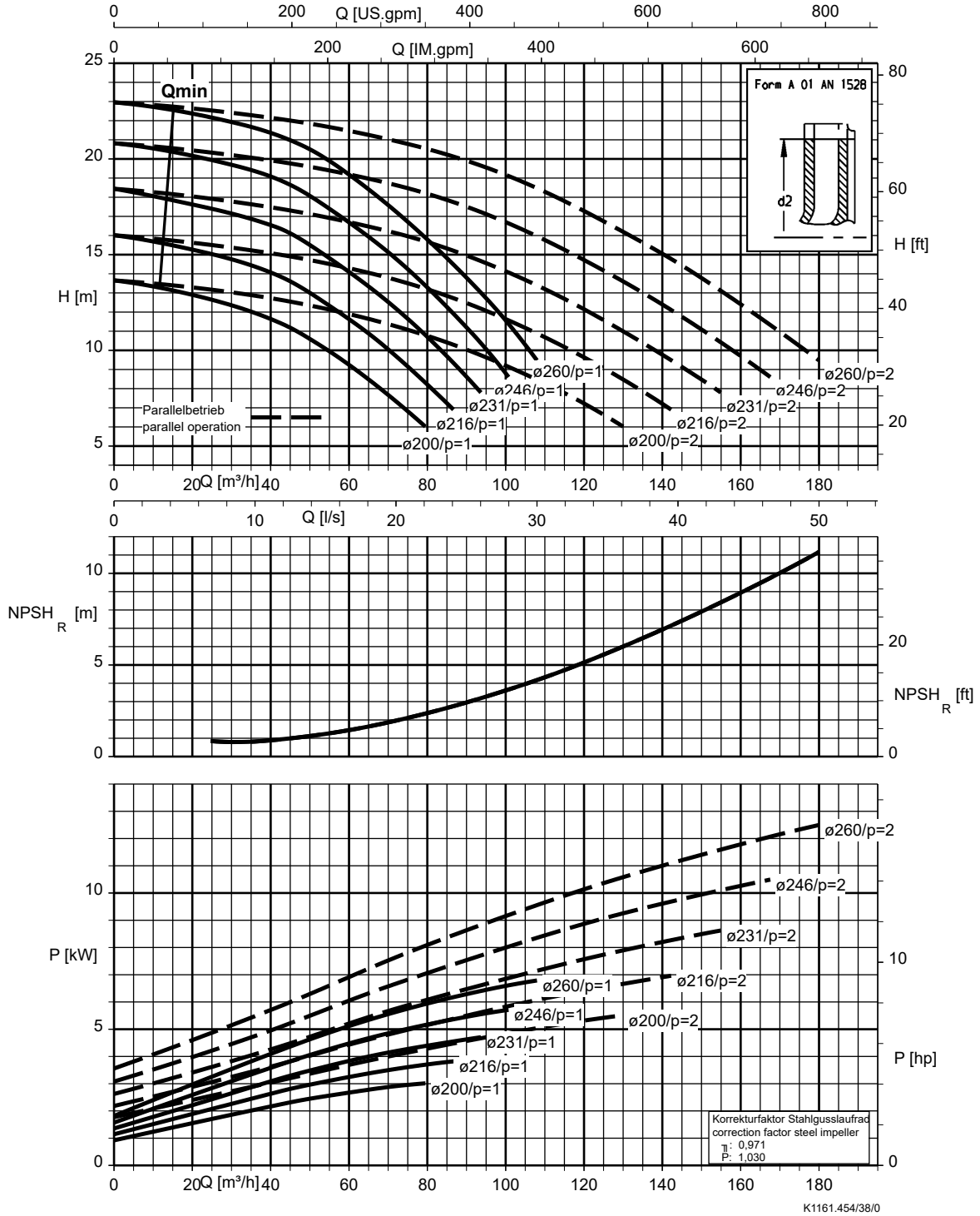

Etaline Z 100-100-200, n = 1450 rpm

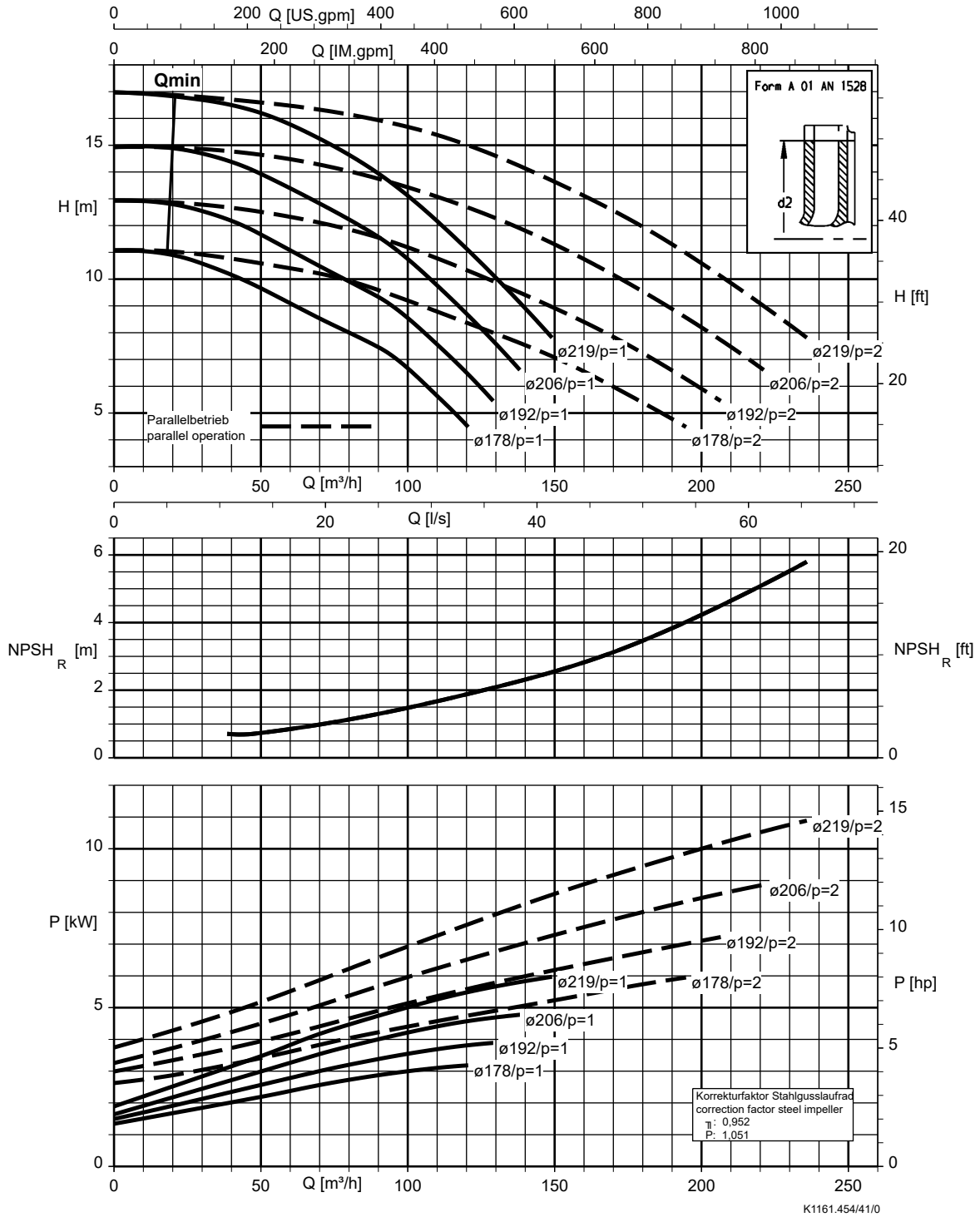

Etaline Z 100-100-250, n = 1450 rpm

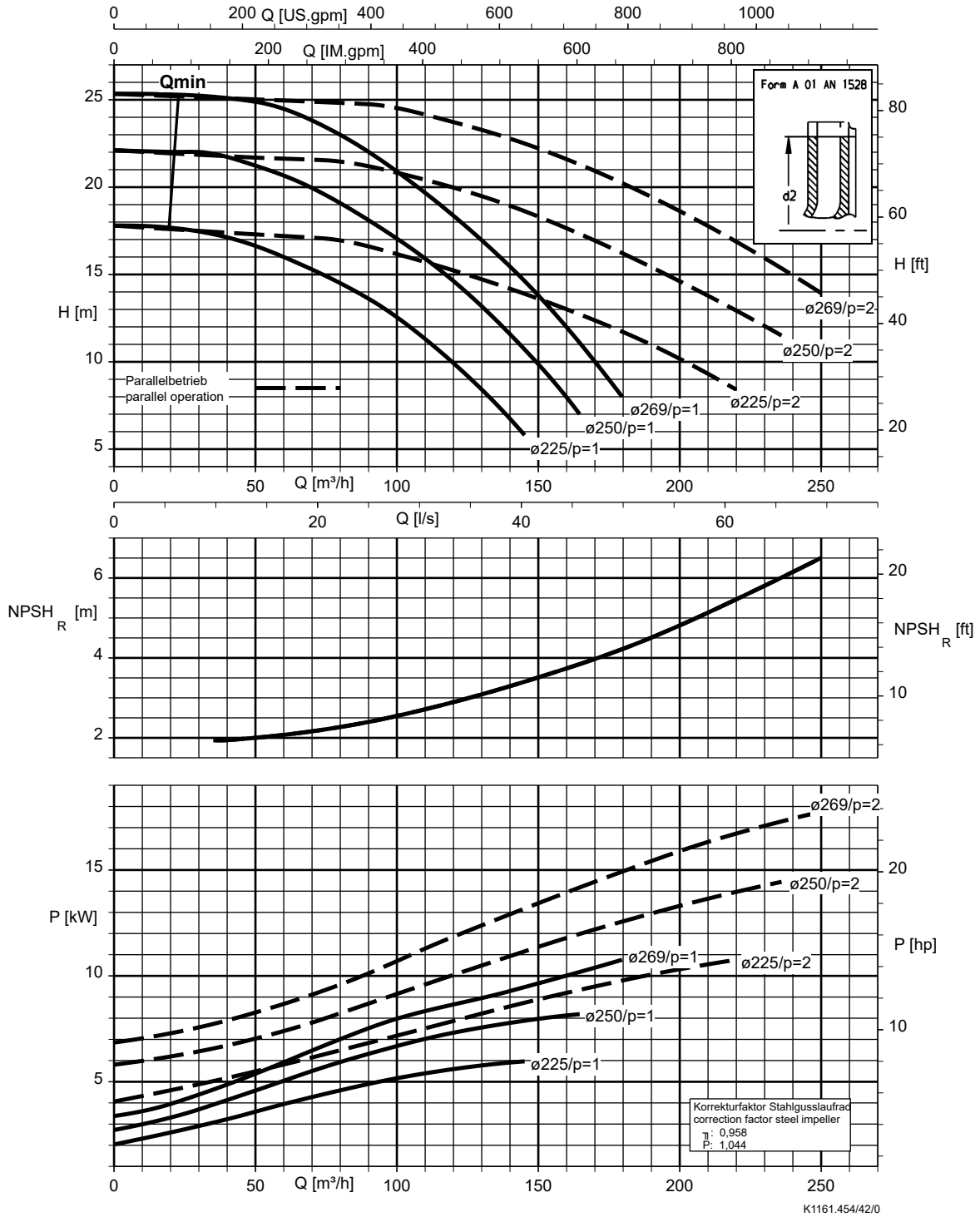

Etaline Z 125-125-200, n = 1450 rpm

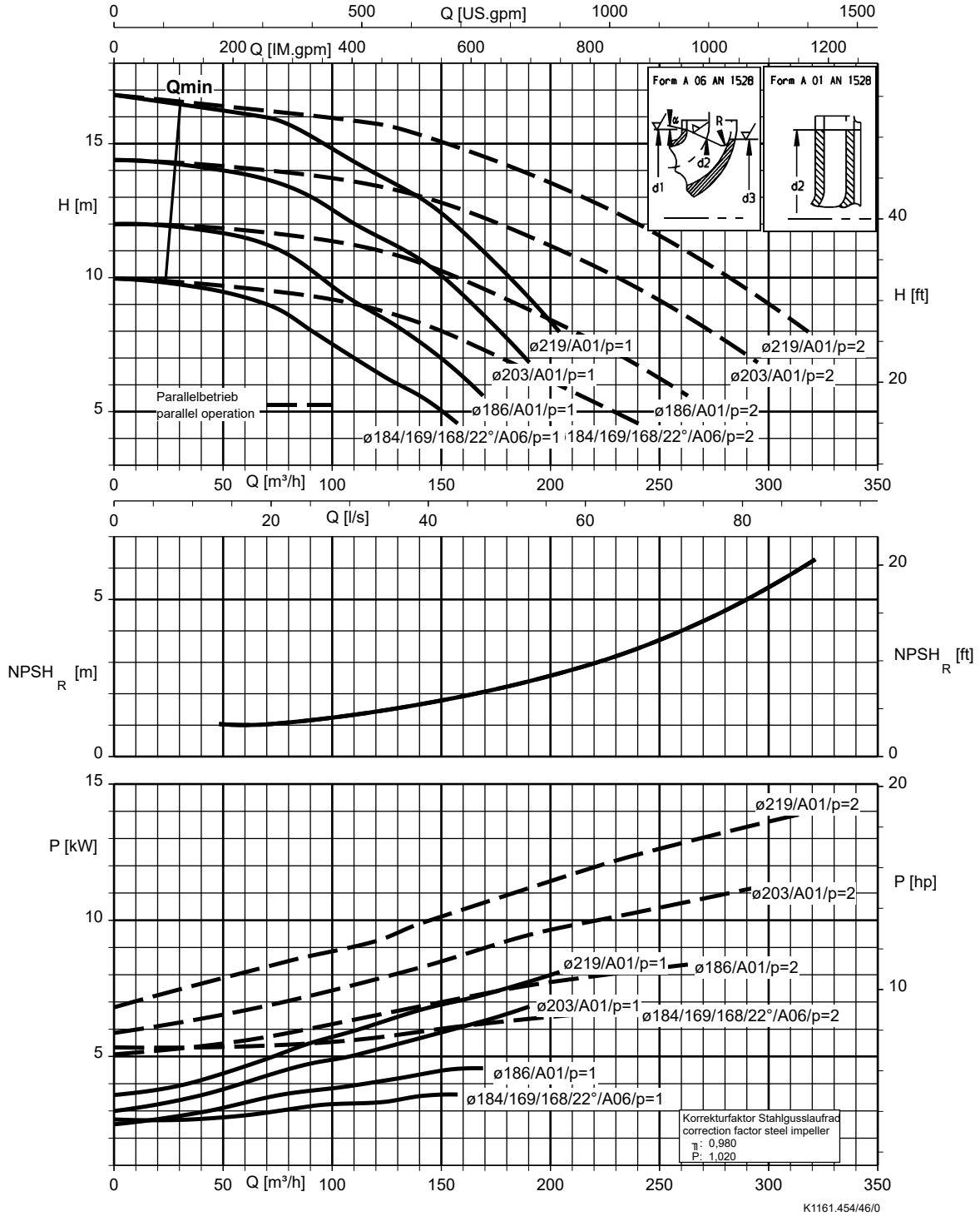

Etaline Z 125-125-250, n = 1450 rpm

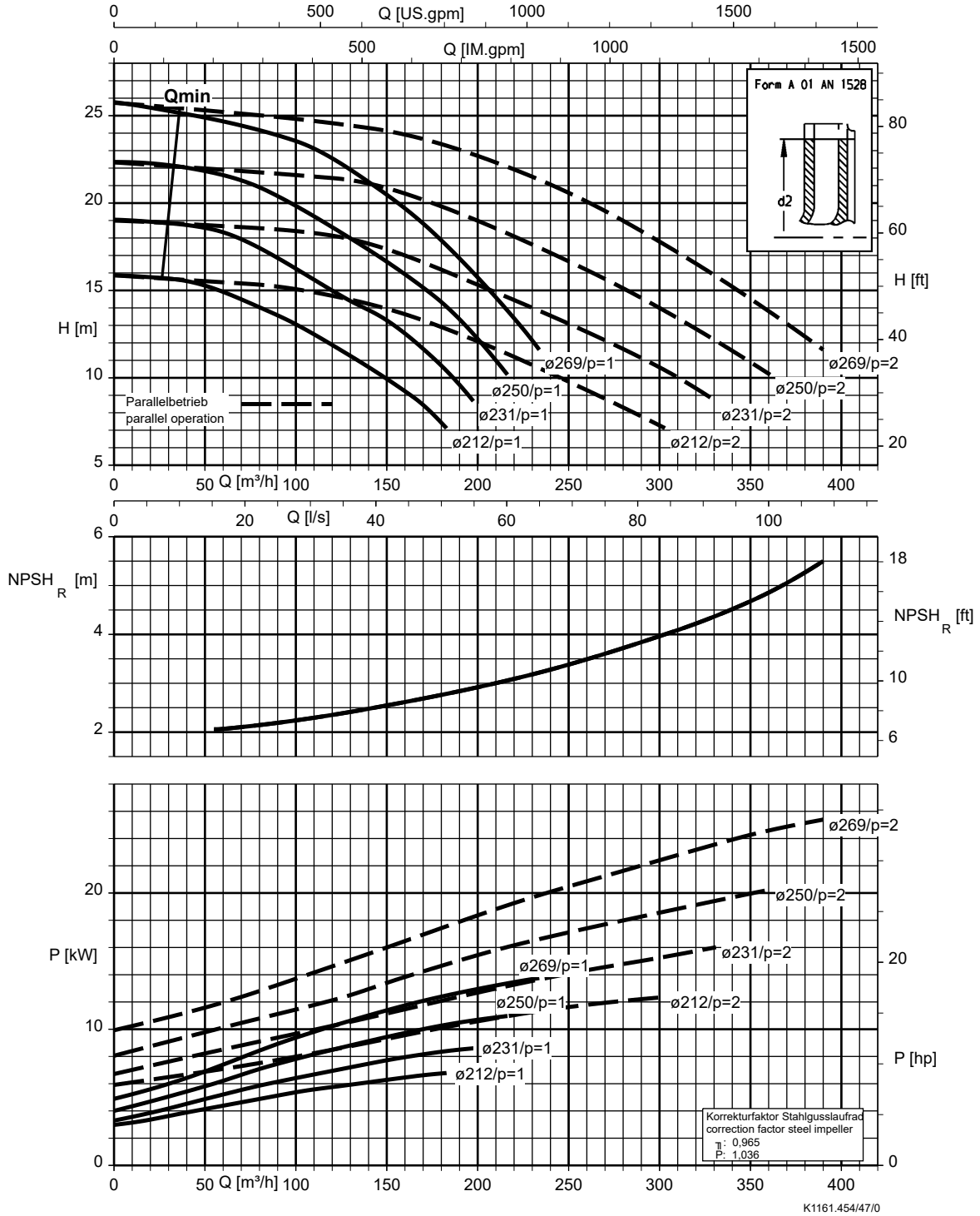

Etaline Z 150-150-250, n = 1450 rpm

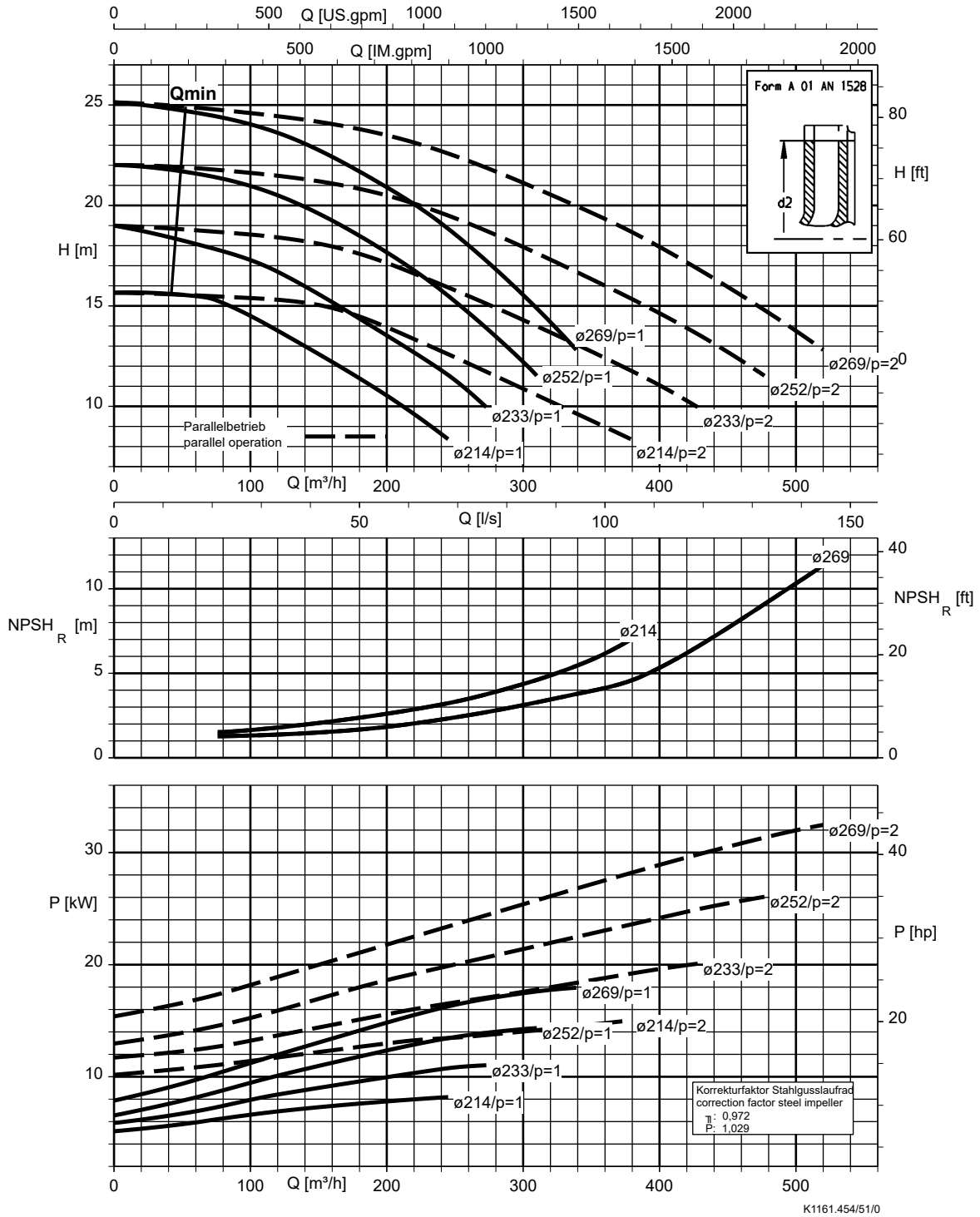

Etaline Z 200-200-250, n = 1450 rpm

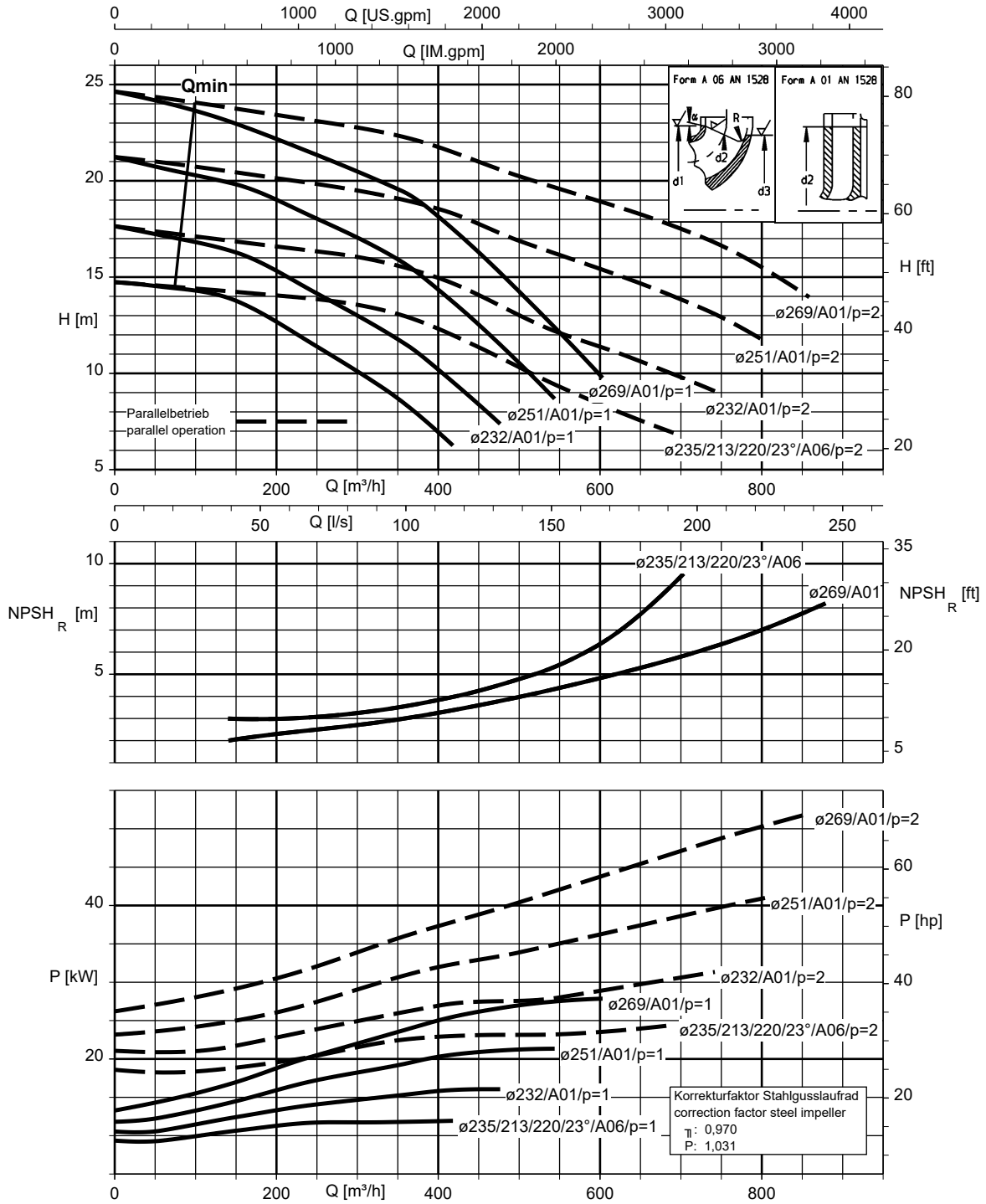

K1161.454/56/0

Etaline Z 200-200-315, n = 1450 rpm

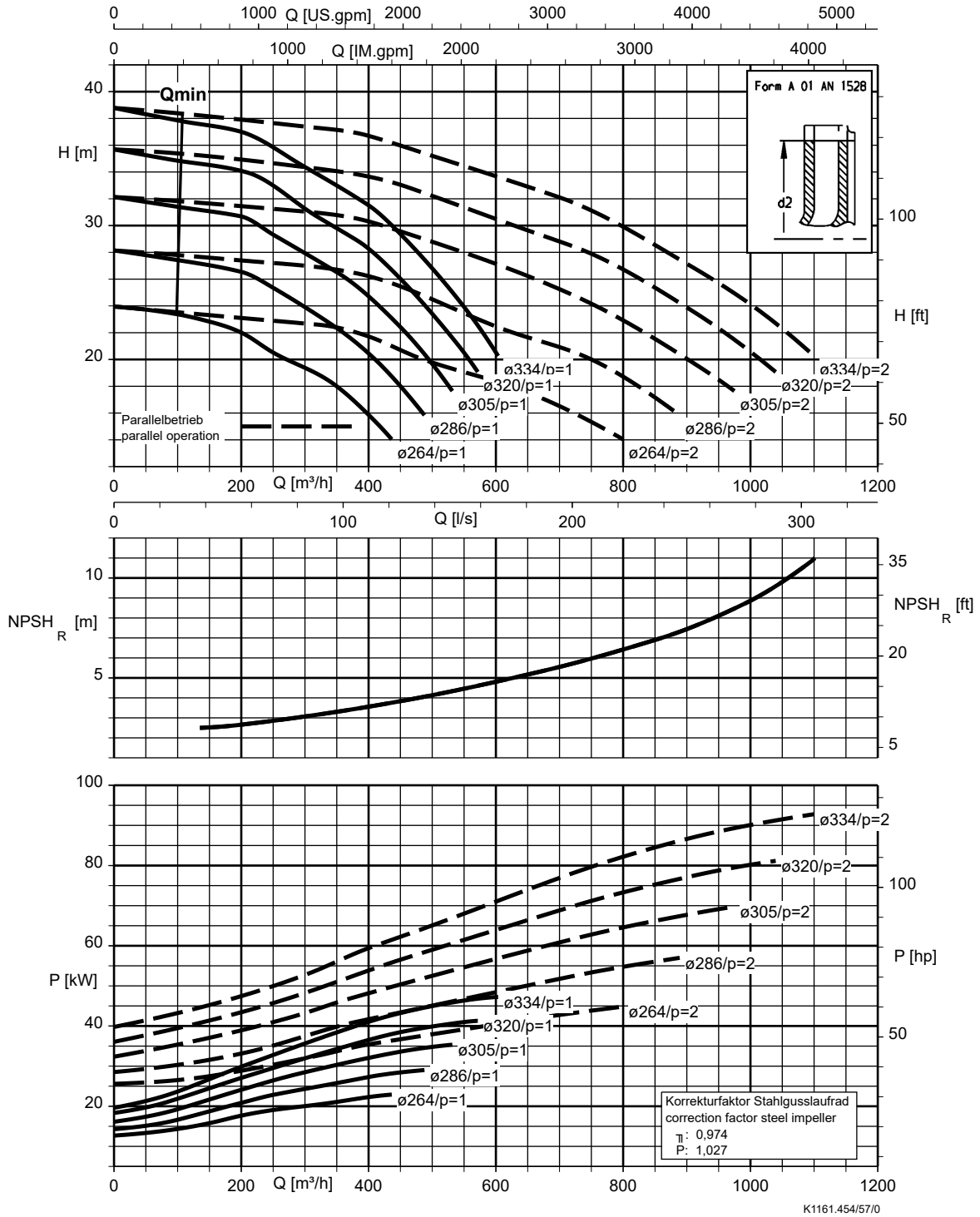

Dimensions

 Pump set (fixed speed version), $n = 1450$ rpm, sizes 032-032-160 to 080-080-250

Fig. 2: Pump set dimensions

(a)	Foundation fastening elements $\varnothing 11.5$ mm	1M.1/2	Pressure gauge connection
(b)	Pump fastening elements M10	6B.1/2	Drain connection
6D.1/2	Vent connection / drain connection	5B	Vent connection for the mechanical seal chamber

 Pump set dimensions (fixed speed version), $n = 1450$ rpm

Etaline Z	P_N	DN ¹⁸⁾	a	b	c	$\approx d$ ¹⁹⁾	d_1	e	$\approx f$ ¹⁹⁾	$\approx g$ ¹⁹⁾	h	h_1	k	k_1	$\approx L$ ¹⁹⁾	$\approx L_1$ ¹⁹⁾	$\approx p$ ¹⁹⁾	t	x
n = 1450 rpm	[kW]		[mm]																
032-032-160	0,25	32	75	140	70	145	M10	235	236	236	170	150	235	117,5	460	237	111	13	100
032-032-160	0,37	32	75	140	70	145	M10	235	236	236	170	150	235	117,5	460	237	111	13	100
032-032-160	0,55	32	75	140	70	162	M10	235	236	236	170	150	235	117,5	498	255	120	13	100
032-032-160	0,75	32	75	140	70	162	M10	235	236	236	170	150	235	117,5	498	255	120	13	100
032-032-160	1,10	32	75	140	70	190	M10	235	236	236	170	150	235	117,5	525	282	128	13	100
032-032-160	1,50	32	75	140	70	190	M10	235	236	236	170	150	235	117,5	551	308	128	13	100
032-032-200	0,37	32	105	180	70	145	M10	285	287	287	190	190	285	142,5	478	237	111	13	100
032-032-200	0,55	32	105	180	70	162	M10	285	287	287	190	190	285	142,5	516	255	120	13	100
032-032-200	0,75	32	105	180	70	162	M10	285	287	287	190	190	285	142,5	516	255	120	13	100
032-032-200	1,10	32	105	180	70	190	M10	285	287	287	190	190	285	142,5	543	282	128	13	100

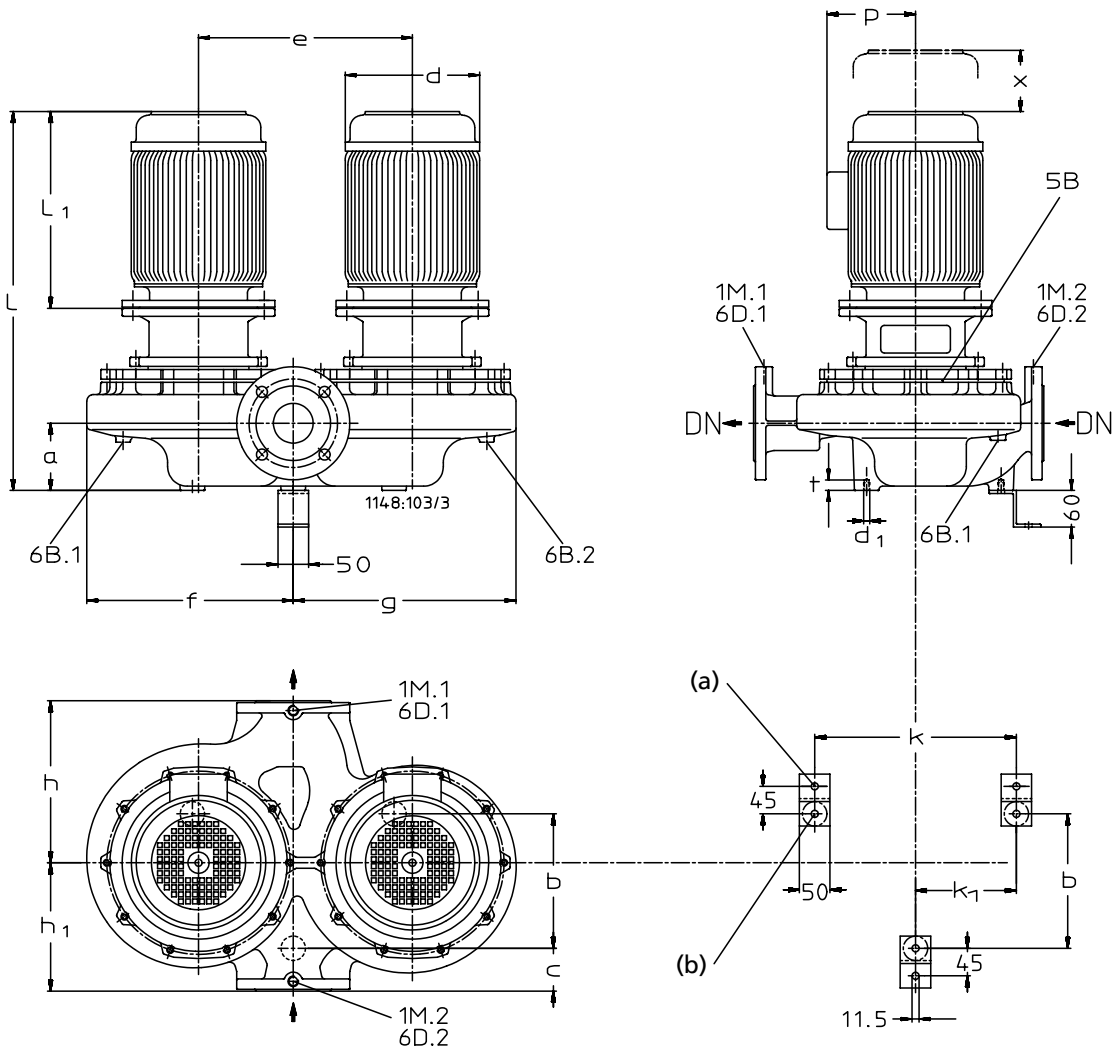
¹⁸ DN = EN 1092-2, PN 16

¹⁹ For the exact motor-related dimensions refer to the general arrangement drawing.

Etaline Z	P _N	DN ₁₈	a	b	c	≈d ₁₉	d ₁	e	≈f ₁₉	≈g ₁₉	h	h ₁	k	k ₁	≈L ₁₉	≈L ₁ ₁₉	≈p ₁₉	t	x
n = 1450 rpm	[kW]	[mm]																	
032-032-200	1,50	32	105	180	70	190	M10	285	287	287	190	190	285	142,5	569	308	128	13	100
032-032-200	2,20	32	105	180	70	213	M10	285	287	287	190	190	285	142,5	622	347	135	13	100
032-032-200	3,00	32	105	180	70	213	M10	285	287	287	190	190	285	142,5	657	382	135	13	100
032-032-200	4,00	32	105	180	70	234	M10	285	287	287	190	190	285	142,5	646	371	148	13	100
040-040-160	0,25	40	99	140	70	145	M10	250	243	243	170	150	250	125	472	237	111	13	100
040-040-160	0,37	40	99	140	70	145	M10	250	243	243	170	150	250	125	472	237	111	13	100
040-040-160	0,55	40	99	140	70	162	M10	250	243	243	170	150	250	125	510	255	120	13	100
040-040-160	0,75	40	99	140	70	162	M10	250	243	243	170	150	250	125	510	255	120	13	100
040-040-160	1,10	40	99	140	70	190	M10	250	243	243	170	150	250	125	537	282	128	13	100
040-040-160	1,50	40	99	140	70	190	M10	250	243	243	170	150	250	125	563	308	128	13	100
040-040-250	0,55	40	101	224	70	162	M10	330	310	360	220	220	330	190	521	255	120	13	100
040-040-250	0,75	40	101	224	70	162	M10	330	310	360	220	220	330	190	521	255	120	13	100
040-040-250	1,10	40	101	224	70	190	M10	330	310	360	220	220	330	190	548	282	128	13	100
040-040-250	1,50	40	101	224	70	190	M10	330	310	360	220	220	330	190	574	308	128	13	100
040-040-250	2,20	40	101	224	70	213	M10	330	310	360	220	220	330	190	627	347	135	13	100
040-040-250	3,00	40	101	224	70	213	M10	330	310	360	220	220	330	190	662	382	135	13	100
040-040-250	4,00	40	101	224	70	234	M10	330	310	360	220	220	330	190	651	371	148	13	100
040-040-250	5,50	40	101	224	70	266	M10	330	310	360	220	220	330	190	716	413	167	13	100
040-040-250	7,50	40	101	224	70	298	M10	330	310	360	220	220	330	190	744	441	167	13	100
050-050-160	0,25	50	110	160	70	145	M10	270	254	253	180	160	270	135	484	237	111	13	100
050-050-160	0,37	50	110	160	70	145	M10	270	254	253	180	160	270	135	484	237	111	13	100
050-050-160	0,55	50	110	160	70	162	M10	270	254	253	180	160	270	135	522	255	120	13	100
050-050-160	0,75	50	110	160	70	162	M10	270	254	253	180	160	270	135	522	255	120	13	100
050-050-160	1,10	50	110	160	70	190	M10	270	254	253	180	160	270	135	549	282	128	13	100
050-050-160	1,50	50	110	160	70	190	M10	270	254	253	180	160	270	135	575	308	128	13	100
050-050-160	2,20	50	110	160	70	213	M10	270	254	253	180	160	270	135	628	347	135	13	100
050-050-160	3,00	50	110	160	70	213	M10	270	254	253	180	160	270	135	663	382	135	13	100
050-050-160	4,00	50	110	160	70	234	M10	270	254	253	180	160	270	135	652	371	148	13	100
050-050-250	1,10	50	110	220	70	190	M10	380	361	360	220	220	380	190	548	282	128	13	100
050-050-250	1,50	50	110	220	70	190	M10	380	361	360	220	220	380	190	574	308	128	13	100
050-050-250	2,20	50	110	220	70	213	M10	380	361	360	220	220	380	190	627	347	135	13	100
050-050-250	3,00	50	110	220	70	213	M10	380	361	360	220	220	380	190	662	382	135	13	100
050-050-250	4,00	50	110	220	70	234	M10	380	361	360	220	220	380	190	651	371	148	13	100
050-050-250	5,50	50	110	220	70	266	M10	380	361	360	220	220	380	190	716	413	167	13	100
050-050-250	7,50	50	110	220	70	298	M10	380	361	360	220	220	380	190	744	441	167	13	100
050-050-250	11,00	50	110	220	70	325	M10	380	361	360	220	220	380	190	882	546	197	13	100
065-065-160	0,25	65	133	170	70	145	M10	285	263	260	180	160	285	142,5	506	237	111	13	100
065-065-160	0,37	65	133	170	70	145	M10	285	263	260	180	160	285	142,5	506	237	111	13	100
065-065-160	0,55	65	133	170	70	162	M10	285	263	260	180	160	285	142,5	544	255	120	13	100
065-065-160	0,75	65	133	170	70	162	M10	285	263	260	180	160	285	142,5	544	255	120	13	100
065-065-160	1,10	65	133	170	70	190	M10	285	263	260	180	160	285	142,5	571	282	128	13	100
065-065-160	1,50	65	133	170	70	190	M10	285	263	260	180	160	285	142,5	597	308	128	13	100
065-065-160	2,20	65	133	170	70	213	M10	285	263	260	180	160	285	142,5	650	347	135	13	100
065-065-160	3,00	65	133	170	70	213	M10	285	263	260	180	160	285	142,5	685	382	135	13	100
065-065-160	4,00	65	133	170	70	234	M10	285	263	260	180	160	285	142,5	674	371	148	13	100
065-065-250	1,50	65	110	220	70	190	M10	350	339	366	265	210	330	165	599	308	128	13	100
065-065-250	2,20	65	110	220	70	213	M10	350	339	366	265	210	330	165	652	347	135	13	100
065-065-250	3,00	65	110	220	70	213	M10	350	339	366	265	210	330	165	687	382	135	13	100
065-065-250	4,00	65	110	220	70	234	M10	350	339	366	265	210	330	165	676	371	148	13	100
065-065-250	5,50	65	110	220	70	266	M10	350	339	366	265	210	330	165	741	413	167	13	100
065-065-250	7,50	65	110	220	70	298	M10	350	339	366	265	210	330	165	769	441	167	13	100
080-080-160	0,55	80	120	175	70	162	M10	324	290	280	195	165	324	162	546	255	120	13	100
080-080-160	0,75	80	120	175	70	162	M10	324	290	280	195	165	324	162	546	255	120	13	100
080-080-160	1,10	80	120	175	70	190	M10	324	290	280	195	165	324	162	573	282	128	13	100
080-080-160	1,50	80	120	175	70	190	M10	324	290	280	195	165	324	162	599	308	128	13	100
080-080-160	2,20	80	120	175	70	213	M10	324	290	280	195	165	324	162	652	347	135	13	100
080-080-160	3,00	80	120	175	70	213	M10	324	290	280	195	165	324	162	687	382	135	13	100

Etaline Z	P _N	DN ₁₈₎	a	b	c	≈d ₁₉₎	d ₁	e	≈f ₁₉₎	≈g ₁₉₎	h	h ₁	k	k ₁	≈L ₁₉₎	≈L ₁₉₎	≈p ₁₉₎	t	x
n = 1450 rpm	[kW]	[mm]																	
080-080-160	4,00	80	120	175	70	234	M10	324	290	280	195	165	324	162	676	371	148	13	100
080-080-160	5,50	80	120	175	70	266	M10	324	290	280	195	165	324	162	741	413	167	13	100
080-080-250	2,20	80	109	224	70	213	M10	345	333	364	290	210	345	172,5	667	347	135	13	140
080-080-250	3,00	80	109	224	70	213	M10	345	333	364	290	210	345	172,5	702	382	135	13	140
080-080-250	4,00	80	109	224	70	234	M10	345	333	364	290	210	345	172,5	691	371	148	13	140
080-080-250	5,50	80	109	224	70	266	M10	345	333	364	290	210	345	172,5	756	413	167	13	140
080-080-250	7,50	80	109	224	70	298	M10	345	333	364	290	210	345	172,5	784	441	167	13	140

Pump set (fixed speed version), $n = 1450 \text{ rpm}$, sizes 100-100-200 to 200-200-315

Fig. 3: Pump set dimensions

(a)	Foundation fastening elements $\varnothing 18$	1M.1/2	Pressure gauge connection
(b)	Pump fastening elements M16	6B.1/2	Drain connection
6D.1/2	Vent connection / drain connection	5B	Vent connection for the mechanical seal chamber

 Pump set dimensions (fixed speed version), $n = 1450 \text{ rpm}$

Etaline Z	P_N	DN ²⁰⁾	a	b	c	$\approx d$ ²¹⁾	d_1	e	$\approx f$ ²¹⁾	$\approx g$ ²¹⁾	h	h_1	k	k_1	$\approx L$ ²¹⁾	$\approx L_1$ ²¹⁾	$\approx p$ ²¹⁾	t	x
100-100-200	2,20	100	196	280	98	213	M16	410	394	376	280	270	410	205	733	347	135	20	150
100-100-200	3,00	100	196	280	98	213	M16	410	394	376	280	270	410	205	768	382	135	20	150
100-100-200	4,00	100	196	280	98	234	M16	410	394	376	280	270	410	205	757	371	148	20	150
100-100-200	5,50	100	196	280	98	266	M16	410	394	376	280	270	410	205	822	413	167	20	150
100-100-200	7,50	100	196	280	98	298	M16	410	394	376	280	270	410	205	850	441	167	20	150
100-100-200	11,00	100	196	280	98	325	M16	410	394	376	280	270	410	205	988	546	197	20	150
100-100-200	15,00	100	196	280	98	325	M16	410	394	376	280	270	410	205	994	552	197	20	150
100-100-200	18,50	100	196	280	98	370	M16	410	394	376	280	270	410	205	1052	610	262	20	150
100-100-250	4,00	100	175	270	105	234	M16	480	453	439	295	255	480	240	760	371	148	20	140

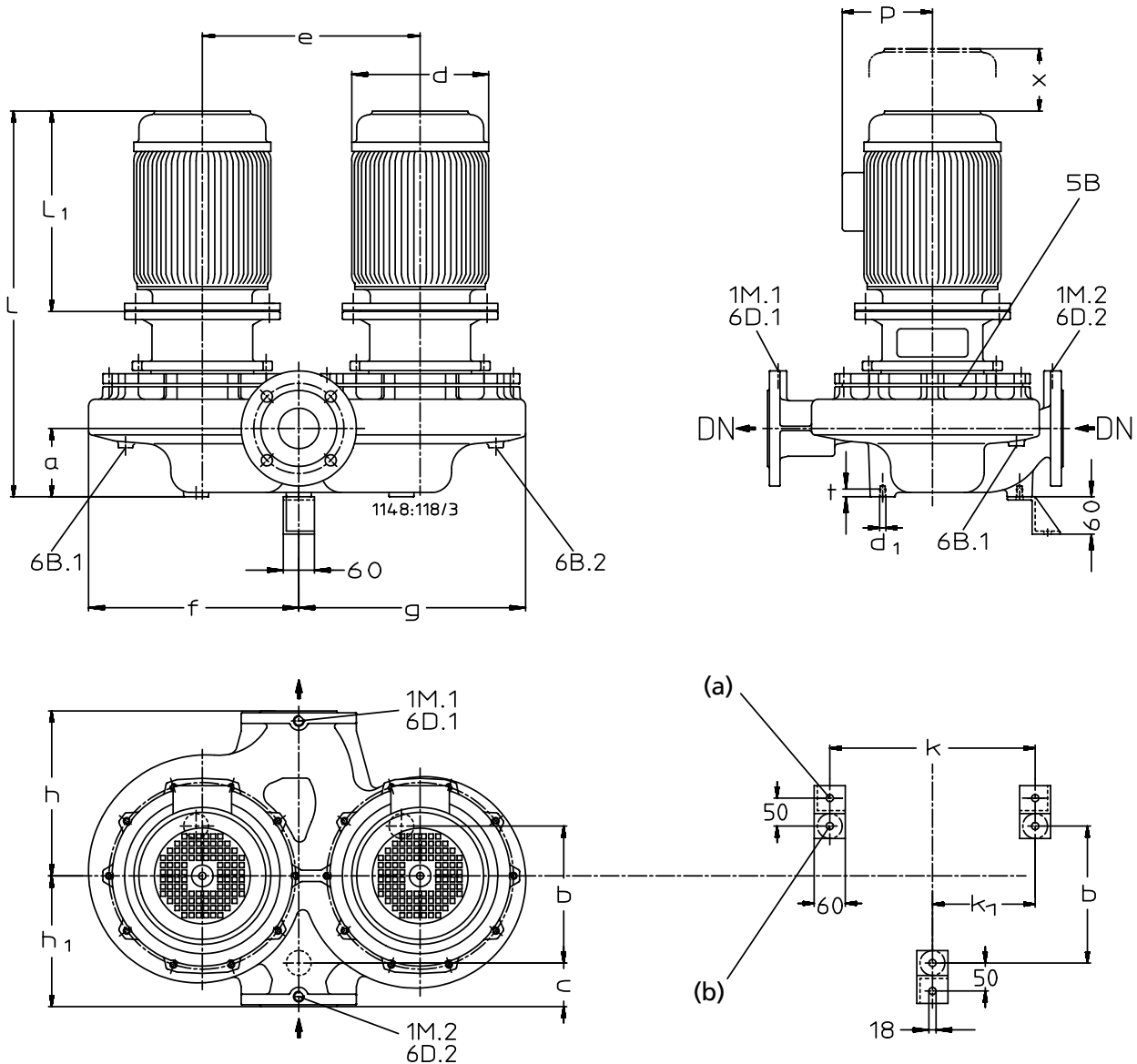
²⁰ DN = EN 1092-2, PN 16

²¹ For the exact motor-related dimensions refer to the general arrangement drawing.

Etaline Z	P _N	DN ₂₀	a	b	c	≈d ₂₁	d ₁	e	≈f ₂₁	≈g ₂₁	h	h ₁	k	k ₁	≈L ₂₁	≈L ₁ ₂₁	≈p ₂₁	t	x
n = 1450 rpm	[kW]	[mm]																	
100-100-250	5,50	100	175	270	105	266	M16	480	453	439	295	255	480	240	825	413	167	20	140
100-100-250	7,50	100	175	270	105	298	M16	480	453	439	295	255	480	240	853	441	167	20	140
100-100-250	11,00	100	175	270	105	325	M16	480	453	439	295	255	480	240	991	546	197	20	140
100-100-250	15,00	100	175	270	105	325	M16	480	453	439	295	255	480	240	997	552	197	20	140
100-100-250	18,50	100	175	270	105	370	M16	480	453	439	295	255	480	240	1055	610	262	20	140
100-100-250	22,00	100	175	270	105	370	M16	480	453	439	295	255	480	240	1055	610	262	20	140
100-100-250	30,00	100	175	270	105	422	M16	480	453	439	295	255	480	240	1114	669	305	20	140
125-125-200	2,20	125	221	265	95	213	M16	380	394	366	345	275	550	275	758	347	135	20	155
125-125-200	3,00	125	221	265	95	213	M16	380	394	366	345	275	550	275	793	382	135	20	155
125-125-200	4,00	125	221	265	95	234	M16	380	394	366	345	275	550	275	782	371	148	20	155
125-125-200	5,50	125	221	265	95	266	M16	380	394	366	345	275	550	275	847	413	167	20	155
125-125-200	7,50	125	221	265	95	298	M16	380	394	366	345	275	550	275	875	441	167	20	155
125-125-200	11,00	125	221	265	95	325	M16	380	394	366	345	275	550	275	1013	546	197	20	155
125-125-200	15,00	125	221	265	95	325	M16	380	394	366	345	275	550	275	1019	552	197	20	155
125-125-200	18,50	125	221	265	95	370	M16	380	394	366	345	275	550	275	1077	610	262	20	155
125-125-200	22,00	125	221	265	95	370	M16	380	394	366	345	275	550	275	1077	610	262	20	155
125-125-250	4,00	125	226	300	85	234	M16	400	409	389	360	260	400	200	787	371	148	20	145
125-125-250	5,50	125	226	300	85	266	M16	400	409	389	360	260	400	200	852	413	167	20	145
125-125-250	7,50	125	226	300	85	298	M16	400	409	389	360	260	400	200	880	441	167	20	145
125-125-250	11,00	125	226	300	85	325	M16	400	409	389	360	260	400	200	1018	546	197	20	145
125-125-250	15,00	125	226	300	85	325	M16	400	409	389	360	260	400	200	1024	552	197	20	145
125-125-250	18,50	125	226	300	85	370	M16	400	409	389	360	260	400	200	1082	610	262	20	145
125-125-250	22,00	125	226	300	85	370	M16	400	409	389	360	260	400	200	1082	610	262	20	145
150-150-250	7,50	150	256	320	120	298	M16	600	560	534	400	300	600	300	910	441	167	20	155
150-150-250	11,00	150	256	320	120	325	M16	600	560	534	400	300	600	300	1048	546	197	20	155
150-150-250	15,00	150	256	320	120	325	M16	600	560	534	400	300	600	300	1054	552	197	20	155
150-150-250	18,50	150	256	320	120	370	M16	600	560	534	400	300	600	300	1112	610	262	20	155
150-150-250	22,00	150	256	320	120	370	M16	600	560	534	400	300	600	300	1112	610	262	20	155
150-150-250	30,00	150	256	320	120	422	M16	600	560	534	400	300	600	300	1171	669	305	20	155
150-150-250	37,00	150	256	320	120	460	M16	600	560	534	400	300	600	300	1228	695	325	20	155
150-150-250	45,00	150	256	320	120	468	M16	600	560	534	400	300	600	300	1258	725	325	20	155
200-200-250	11,00	200	281	410	210	325	M16	600	585	537	530	470	600	300	1073	546	197	20	160
200-200-250	15,00	200	281	410	210	325	M16	600	585	537	530	470	600	300	1079	552	197	20	160
200-200-250	18,50	200	281	410	210	370	M16	600	585	537	530	470	600	300	1137	610	262	20	160
200-200-250	22,00	200	281	410	210	370	M16	600	585	537	530	470	600	300	1137	610	262	20	160
200-200-250	30,00	200	281	410	210	422	M16	600	585	537	530	470	600	300	1196	669	305	20	160
200-200-250	37,00	200	281	410	210	460	M16	600	585	537	530	470	600	300	1253	695	325	20	160
200-200-250	45,00	200	281	410	210	468	M16	600	585	537	530	470	600	300	1283	725	325	20	160
200-200-315	30,00	200	287	410	220	422	M16	580	593	554	520	480	580	290	1202	669	305	20	185
200-200-315	37,00	200	287	410	220	460	M16	580	593	554	520	480	580	290	1259	695	325	20	185
200-200-315	45,00	200	287	410	220	468	M16	580	593	554	520	480	580	290	1289	725	325	20	185
200-200-315	55,00	200	287	410	220	520	M16	580	593	554	520	480	580	290	1393	817	392	20	185

Pump set (variable speed version), n = 1500 rpm, sizes 032-032-160 to 080-080-250

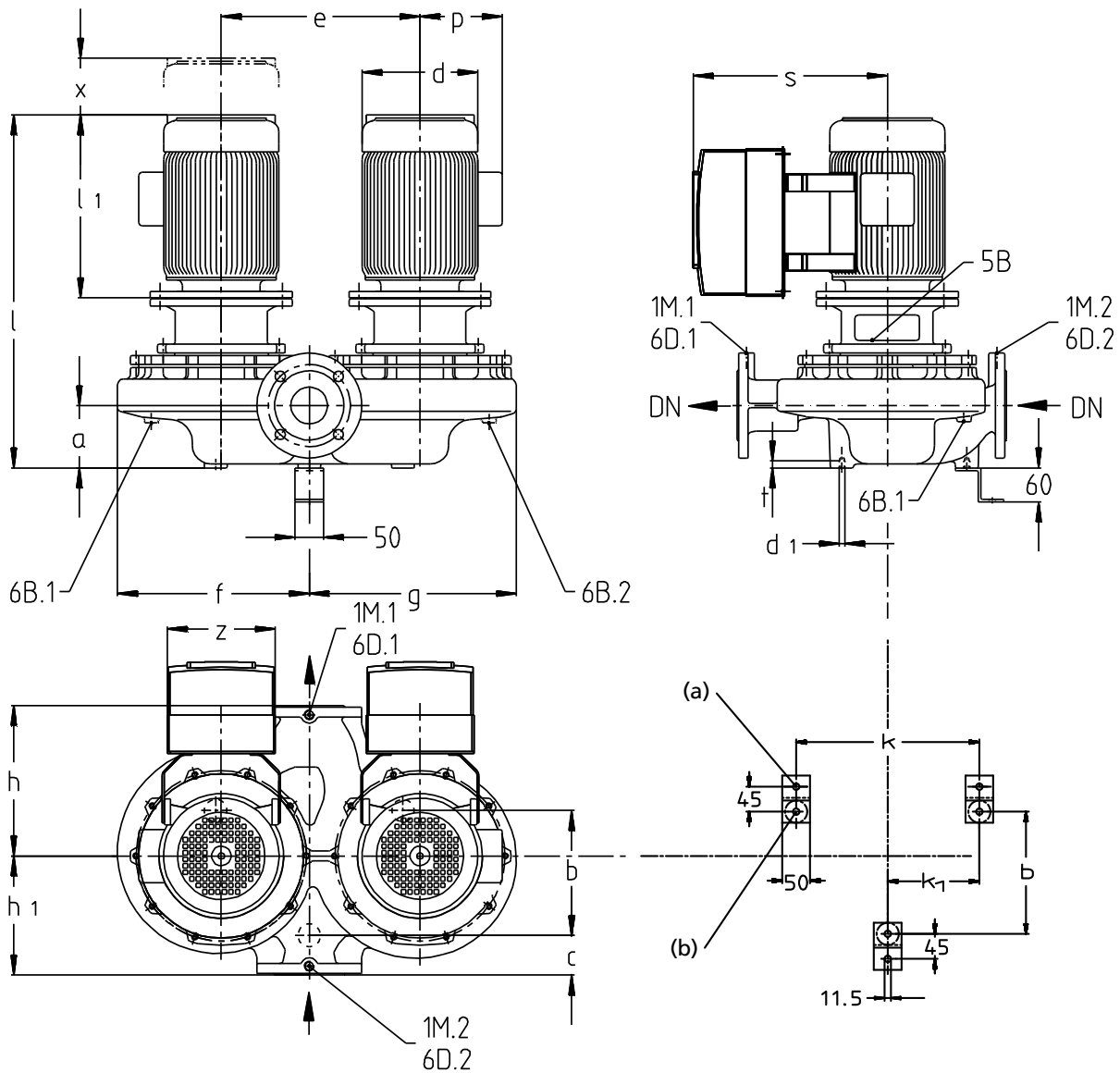

Fig. 4: Pump set dimensions with PumpDrive 2

(a)	Foundation fastening elements \varnothing 11.5	1M.1/2	Connection for pressure gauge
(b)	Pump fastening elements M10	6B.1/2	Drain connection
6D.1/2	Vent connection / drain connection	5B	Vent connection for the mechanical seal chamber

Dimensions of pump set with PumpDrive 2 (variable speed version), n = 1500 rpm

Etaline Z PumpDrive 2	P_N	DN ²²⁾	a	b	c	$\approx d$ ²³⁾	d_1	e	$\approx f$ ²³⁾	$\approx g$ ²³⁾	h	h_1	k	k_1	$\approx L$ ²³⁾	$\approx L_1$ ²³⁾	$\approx p$ ²³⁾	$\approx s$ ²³⁾	t	x	z
n = 1500 rpm	[kW]		[mm]																		
032-032-160	0,55	32	75	140	70	162	M10	235	236	236	170	150	235	117,5	498	255	120	294	13	100	190
032-032-160	0,75	32	75	140	70	162	M10	235	236	236	170	150	235	117,5	498	255	120	294	13	100	190
032-032-160	1,10	32	75	140	70	190	M10	235	236	236	170	150	235	117,5	525	282	128	299	13	100	190
032-032-160	1,50	32	75	140	70	190	M10	235	236	236	170	150	235	117,5	551	308	128	299	13	100	190
032-032-200	0,55	32	105	180	70	162	M10	285	287	287	190	190	285	142,5	516	255	120	294	13	100	190
032-032-200	0,75	32	105	180	70	162	M10	285	287	287	190	190	285	142,5	516	255	120	294	13	100	190
032-032-200	1,10	32	105	180	70	190	M10	285	287	287	190	190	285	142,5	543	282	128	299	13	100	190
032-032-200	1,50	32	105	180	70	190	M10	285	287	287	190	190	285	142,5	569	308	128	299	13	100	190
032-032-200	2,20	32	105	180	70	213	M10	285	287	287	190	190	285	142,5	622	347	135	338	13	100	211
032-032-200	3,00	32	105	180	70	213	M10	285	287	287	190	190	285	142,5	657	382	135	338	13	100	211

²² DN = EN 1092-2, PN 16

²³ For the exact motor-related dimensions refer to the general arrangement drawing in KSB EasySelect.

Etaline Z PumpDrive 2	P _N	DN ₂₃₎	a	b	c	≈d ₂₃₎	d ₁	e	≈f ₂₃₎	≈g ₂₃₎	h	h ₁	k	k ₁	≈L ₂₃₎	≈L ₁ ₂₃₎	≈p ₂₃₎	≈s ₂₃₎	t	x	z
n = 1500 rpm	[kW]	[mm]																			
032-032-200	4,00	32	105	180	70	234	M10	285	287	287	190	190	285	142,5	646	371	148	353	13	100	211
040-040-160	0,55	40	99	140	70	162	M10	250	243	243	170	150	250	125	510	255	120	294	13	100	190
040-040-160	0,75	40	99	140	70	162	M10	250	243	243	170	150	250	125	510	255	120	294	13	100	190
040-040-160	1,10	40	99	140	70	190	M10	250	243	243	170	150	250	125	537	282	128	299	13	100	190
040-040-160	1,50	40	99	140	70	190	M10	250	243	243	170	150	250	125	563	308	128	299	13	100	190
040-040-250	0,75	40	101	224	70	162	M10	330	310	360	220	220	330	190	521	255	120	294	13	100	190
040-040-250	1,10	40	101	224	70	190	M10	330	310	360	220	220	330	190	548	282	128	299	13	100	190
040-040-250	1,50	40	101	224	70	190	M10	330	310	360	220	220	330	190	574	308	128	299	13	100	190
040-040-250	2,20	40	101	224	70	213	M10	330	310	360	220	220	330	190	627	347	135	338	13	100	211
040-040-250	3,00	40	101	224	70	213	M10	330	310	360	220	220	330	190	662	382	135	338	13	100	211
040-040-250	4,00	40	101	224	70	234	M10	330	310	360	220	220	330	190	651	371	148	353	13	100	211
040-040-250	5,50	40	101	224	70	266	M10	330	310	360	220	220	330	190	716	413	167	374	13	100	255
040-040-250	7,50	40	101	224	70	298	M10	330	310	360	220	220	330	190	744	441	167	374	13	100	255
050-050-160	0,55	50	110	160	70	162	M10	270	254	253	180	160	270	135	522	255	120	294	13	100	190
050-050-160	0,75	50	110	160	70	162	M10	270	254	253	180	160	270	135	522	255	120	294	13	100	190
050-050-160	1,10	50	110	160	70	190	M10	270	254	253	180	160	270	135	549	282	128	299	13	100	190
050-050-160	1,50	50	110	160	70	190	M10	270	254	253	180	160	270	135	575	308	128	299	13	100	190
050-050-160	2,20	50	110	160	70	213	M10	270	254	253	180	160	270	135	628	347	135	338	13	100	211
050-050-160	3,00	50	110	160	70	213	M10	270	254	253	180	160	270	135	663	382	135	338	13	100	211
050-050-160	4,00	50	110	160	70	234	M10	270	254	253	180	160	270	135	652	371	148	353	13	100	211
050-050-250	1,10	50	110	220	70	190	M10	380	361	360	220	220	380	190	548	282	128	299	13	100	190
050-050-250	1,50	50	110	220	70	190	M10	380	361	360	220	220	380	190	574	308	128	299	13	100	190
050-050-250	2,20	50	110	220	70	213	M10	380	361	360	220	220	380	190	627	347	135	338	13	100	211
050-050-250	3,00	50	110	220	70	213	M10	380	361	360	220	220	380	190	662	382	135	338	13	100	211
050-050-250	4,00	50	110	220	70	234	M10	380	361	360	220	220	380	190	651	371	148	353	13	100	211
050-050-250	5,50	50	110	220	70	266	M10	380	361	360	220	220	380	190	716	413	167	374	13	100	255
050-050-250	7,50	50	110	220	70	298	M10	380	361	360	220	220	380	190	744	441	167	374	13	100	255
050-050-250	11,00	50	110	220	70	325	M10	380	361	360	220	220	380	190	882	546	197	405	13	100	255
065-065-160	0,55	65	133	170	70	162	M10	285	263	260	180	160	285	142,5	544	255	120	294	13	100	190
065-065-160	0,75	65	133	170	70	162	M10	285	263	260	180	160	285	142,5	544	255	120	294	13	100	190
065-065-160	1,10	65	133	170	70	190	M10	285	263	260	180	160	285	142,5	571	282	128	299	13	100	190
065-065-160	1,50	65	133	170	70	190	M10	285	263	260	180	160	285	142,5	597	308	128	299	13	100	190
065-065-160	2,20	65	133	170	70	213	M10	285	263	260	180	160	285	142,5	650	347	135	338	13	100	211
065-065-160	3,00	65	133	170	70	213	M10	285	263	260	180	160	285	142,5	685	382	135	338	13	100	211
065-065-160	4,00	65	133	170	70	234	M10	285	263	260	180	160	285	142,5	674	371	148	353	13	100	211
065-065-250	1,50	65	110	220	70	190	M10	350	339	366	265	210	330	165	599	308	128	299	13	100	190
065-065-250	2,20	65	110	220	70	213	M10	350	339	366	265	210	330	165	652	347	135	338	13	100	211
065-065-250	3,00	65	110	220	70	213	M10	350	339	366	265	210	330	165	687	382	135	338	13	100	211
065-065-250	4,00	65	110	220	70	234	M10	350	339	366	265	210	330	165	676	371	148	353	13	100	211
065-065-250	5,50	65	110	220	70	266	M10	350	339	366	265	210	330	165	741	413	167	374	13	100	255
065-065-250	7,50	65	110	220	70	298	M10	350	339	366	265	210	330	165	769	441	167	374	13	100	255
080-080-160	0,75	80	120	175	70	162	M10	324	290	280	195	165	324	162	546	255	120	294	13	100	190
080-080-160	1,10	80	120	175	70	190	M10	324	290	280	195	165	324	162	573	282	128	299	13	100	190
080-080-160	1,50	80	120	175	70	190	M10	324	290	280	195	165	324	162	599	308	128	299	13	100	190
080-080-160	2,20	80	120	175	70	213	M10	324	290	280	195	165	324	162	652	347	135	338	13	100	211
080-080-160	3,00	80	120	175	70	213	M10	324	290	280	195	165	324	162	687	382	135	338	13	100	211
080-080-160	4,00	80	120	175	70	234	M10	324	290	280	195	165	324	162	676	371	148	353	13	100	211
080-080-160	5,50	80	120	175	70	266	M10	324	290	280	195	165	324	162	741	413	167	374	13	100	255
080-080-250	2,20	80	109	224	70	213	M10	345	333	364	290	210	345	172,5	667	347	135	338	13	140	211
080-080-250	3,00	80	109	224	70	213	M10	345	333	364	290	210	345	172,5	702	382	135	338	13	140	211
080-080-250	4,00	80	109	224	70	234	M10	345	333	364	290	210	345	172,5	691	371	148	353	13	140	211
080-080-250	5,50	80	109	224	70	266	M10	345	333	364	290	210	345	172,5	756	413	167	374	13	140	255
080-080-250	7,50	80	109	224	70	298	M10	345	333	364	290	210	345	172,5	784	441	167	374	13	140	255

Pump set (variable speed version), n = 1500 rpm, sizes 100-100-200 to 200-200-315

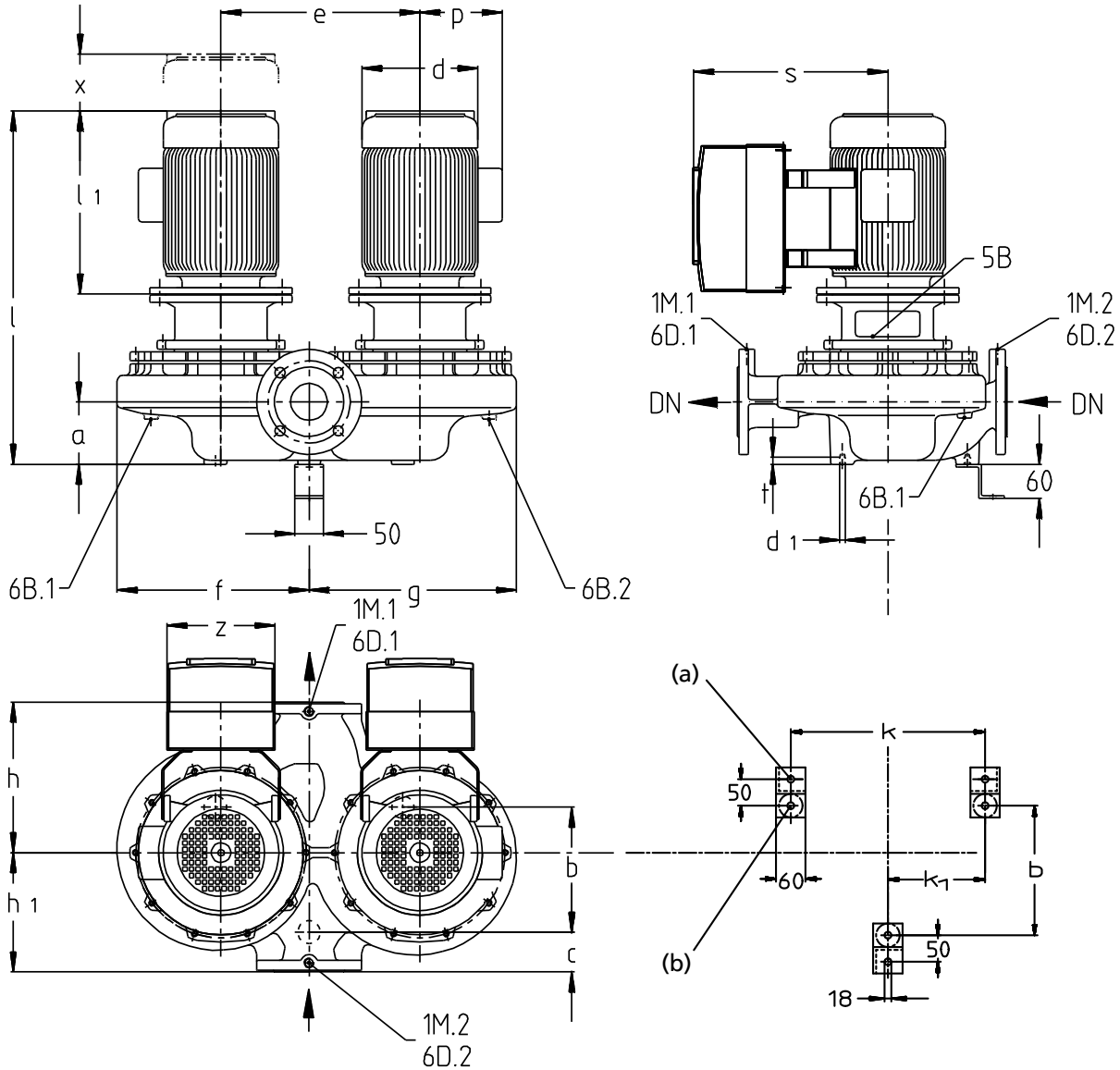

Fig. 5: Pump set dimensions with PumpDrive 2

(a)	Foundation fastening elements \varnothing 18	1M.1/2	Connection for pressure gauge
(b)	Pump fastening elements M16	6B.1/2	Drain connection
6D.1/2	Vent connection / drain connection	5B	Vent connection for the mechanical seal chamber

Dimensions of pump set with PumpDrive 2 (variable speed version), n = 1500 rpm

Etaline Z	P_N	DN ²⁴	a	b	c	$\approx d$ ²⁵	d_1	e	$\approx f$ ²⁵	$\approx g$ ²⁵	h	h_1	k	k_1	$\approx L$ ²⁵	$\approx L_1$ ²⁵	$\approx p$ ²⁵	$\approx s$ ²⁵	t	x	z
PumpDrive 2	[kW]		[mm]																		
n = 1500 rpm																					
100-100-200	2,20	100	196	280	98	213	M16	410	394	376	280	270	410	205	733	347	135	338	20	150	211
100-100-200	3,00	100	196	280	98	213	M16	410	394	376	280	270	410	205	768	382	135	338	20	150	211
100-100-200	4,00	100	196	280	98	234	M16	410	394	376	280	270	410	205	757	371	148	353	20	150	211
100-100-200	5,50	100	196	280	98	266	M16	410	394	376	280	270	410	205	822	413	167	374	20	150	255
100-100-200	7,50	100	196	280	98	298	M16	410	394	376	280	270	410	205	850	441	167	374	20	150	255
100-100-200	11,00	100	196	280	98	325	M16	410	394	376	280	270	410	205	988	546	197	405	20	150	255
100-100-200	15,00	100	196	280	98	325	M16	410	394	376	280	270	410	205	994	552	197	457	20	150	325
100-100-200	18,50	100	196	280	98	370	M16	410	394	376	280	270	410	205	1052	610	262	509	20	150	325
100-100-250	4,00	100	175	270	105	234	M16	480	453	439	295	255	480	240	760	371	148	353	20	140	211
100-100-250	5,50	100	175	270	105	266	M16	480	453	439	295	255	480	240	825	413	167	374	20	140	255

²⁴ DN = EN 1092-2, PN 16

²⁵ For the exact motor-related dimensions refer to the general arrangement drawing in KSB EasySelect.

Etaline Z PumpDrive 2	P _N	DN ₂₄₎	a	b	c	≈d ₂₅₎	d ₁	e	≈f ₂₅₎	≈g ₂₅₎	h	h ₁	k	k ₁	≈L ₂₅₎	≈L _{1 25)}	≈p ₂₅₎	≈s ₂₅₎	t	x	z
n = 1500 rpm	[kW]	[mm]																			
100-100-250	7,50	100	175	270	105	298	M16	480	453	439	295	255	480	240	853	441	167	374	20	140	255
100-100-250	11,00	100	175	270	105	325	M16	480	453	439	295	255	480	240	991	546	197	405	20	140	255
100-100-250	15,00	100	175	270	105	325	M16	480	453	439	295	255	480	240	997	552	197	457	20	140	325
100-100-250	18,50	100	175	270	105	370	M16	480	453	439	295	255	480	240	1055	610	262	509	20	140	325
100-100-250	22,00	100	175	270	105	370	M16	480	453	439	295	255	480	240	1055	610	262	509	20	140	325
100-100-250	30,00	100	175	270	105	422	M16	480	453	439	295	255	480	240	1114	669	305	558	20	140	325
125-125-200	2,20	125	221	265	95	213	M16	380	394	366	345	275	550	275	758	347	135	338	20	155	211
125-125-200	3,00	125	221	265	95	213	M16	380	394	366	345	275	550	275	793	382	135	338	20	155	211
125-125-200	4,00	125	221	265	95	234	M16	380	394	366	345	275	550	275	782	371	148	353	20	155	211
125-125-200	5,50	125	221	265	95	266	M16	380	394	366	345	275	550	275	847	413	167	374	20	155	255
125-125-200	7,50	125	221	265	95	298	M16	380	394	366	345	275	550	275	875	441	167	374	20	155	255
125-125-200	11,00	125	221	265	95	325	M16	380	394	366	345	275	550	275	1013	546	197	405	20	155	255
125-125-200	15,00	125	221	265	95	325	M16	380	394	366	345	275	550	275	1019	552	197	457	20	155	255
125-125-200	18,50	125	221	265	95	370	M16	380	394	366	345	275	550	275	1077	610	262	509	20	155	325
125-125-200	22,00	125	221	265	95	370	M16	380	394	366	345	275	550	275	1077	610	262	509	20	155	325
125-125-250	4,00	125	226	300	85	234	M16	400	409	389	360	260	400	200	787	371	148	353	20	145	211
125-125-250	5,50	125	226	300	85	266	M16	400	409	389	360	260	400	200	852	413	167	374	20	145	255
125-125-250	7,50	125	226	300	85	298	M16	400	409	389	360	260	400	200	880	441	167	374	20	145	255
125-125-250	11,00	125	226	300	85	325	M16	400	409	389	360	260	400	200	1018	546	197	405	20	145	255
125-125-250	15,00	125	226	300	85	325	M16	400	409	389	360	260	400	200	1024	552	197	457	20	145	325
125-125-250	18,50	125	226	300	85	370	M16	400	409	389	360	260	400	200	1082	610	262	509	20	145	325
125-125-250	22,00	125	226	300	85	370	M16	400	409	389	360	260	400	200	1082	610	262	509	20	145	325
150-150-250	7,50	150	256	320	120	298	M16	600	560	534	400	300	600	300	910	441	167	374	20	155	255
150-150-250	11,00	150	256	320	120	325	M16	600	560	534	400	300	600	300	1048	546	197	405	20	155	255
150-150-250	15,00	150	256	320	120	325	M16	600	560	534	400	300	600	300	1054	552	197	457	20	155	325
150-150-250	18,50	150	256	320	120	370	M16	600	560	534	400	300	600	300	1112	610	262	509	20	155	325
150-150-250	22,00	150	256	320	120	370	M16	600	560	534	400	300	600	300	1112	610	262	509	20	155	325
150-150-250	30,00	150	256	320	120	422	M16	600	560	534	400	300	600	300	1171	669	305	558	20	155	325
150-150-250	37,00	150	256	320	120	460	M16	600	560	534	400	300	600	300	1228	695	325	597	20	155	425
150-150-250	45,00	150	256	320	120	468	M16	600	560	534	400	300	600	300	1258	725	325	597	20	155	425
200-200-250	11,00	200	281	410	210	325	M16	600	585	537	530	470	600	300	1073	546	197	405	20	160	255
200-200-250	15,00	200	281	410	210	325	M16	600	585	537	530	470	600	300	1079	552	197	457	20	160	325
200-200-250	18,50	200	281	410	210	370	M16	600	585	537	530	470	600	300	1137	610	262	509	20	160	325
200-200-250	22,00	200	281	410	210	370	M16	600	585	537	530	470	600	300	1137	610	262	509	20	160	325
200-200-250	30,00	200	281	410	210	422	M16	600	585	537	530	470	600	300	1196	669	305	558	20	160	325
200-200-250	37,00	200	281	410	210	460	M16	600	585	537	530	470	600	300	1253	695	325	597	20	160	425
200-200-250	45,00	200	281	410	210	468	M16	600	585	537	530	470	600	300	1283	725	325	597	20	160	425
200-200-315	30,00	200	287	410	220	422	M16	580	593	554	520	480	580	290	1202	669	305	558	20	185	325
200-200-315	37,00	200	287	410	220	460	M16	580	593	554	520	480	580	290	1259	695	325	597	20	185	425
200-200-315	45,00	200	287	410	220	468	M16	580	593	554	520	480	580	290	1289	725	325	597	20	185	425

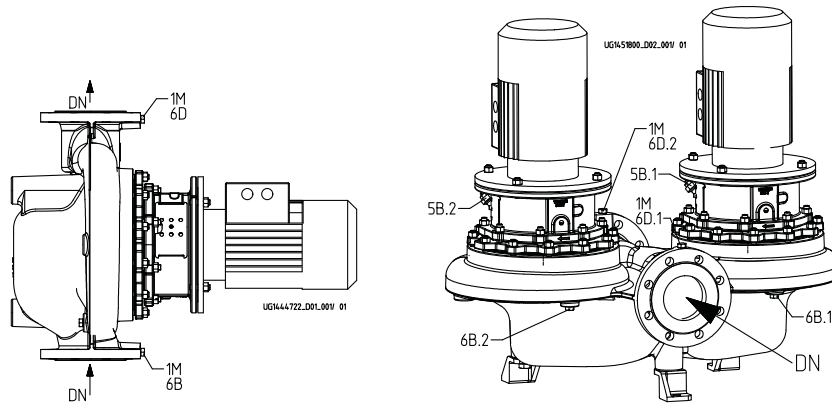
Connections

Fig. 6: Connections
Connections

Connection	Description	Configuration	Position
1M	Connection for pressure gauge	Drilled and closed, or pressure sensor for PumpMeter (if selected)	Suction flange and discharge flange
5B.1, 5B.2	Vent connection for the mechanical seal chamber	Plugged with vent plug	Casing cover
6B, 6B.1, 6B.2	Fluid drain	Drilled and closed	Volute casing
6D, 6D.1, 6D.2	Fluid priming and venting	Drilled and closed	Volute casing

Connection [mm]

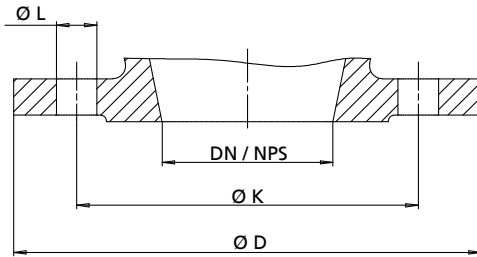
Etaline Z	1M, 6B, 6D	5B
032-032-160	Rc 1/4	G 1/4
032-032-200	Rc 1/4	G 1/4
040-040-160	Rc 1/4	G 1/4
040-040-250	Rc 1/4	G 1/4
050-050-160	Rc 1/4	G 1/4
050-050-250	Rc 1/4	G 1/4
065-065-160	Rc 1/4	G 1/4
065-065-250	Rc 1/4	G 1/4
080-080-160	Rc 3/8	G 1/4
080-080-250	Rc 3/8	G 1/4
100-100-200	Rc 3/8	G 1/4
100-100-250	Rc 3/8	G 1/4
125-125-200	Rc 1/2	G 1/4
125-125-250	Rc 1/2	G 1/4
150-150-250	Rc 1/2	G 1/4
200-200-250	Rc 1/2	G 1/4
200-200-315	Rc 1/2	G 1/4

Flange design

Fig. 7: Flange dimensions

Flange dimensions [mm]

DN / NPS	Standard					
	EN 1092-2			ASME B 16.1		
	Material					
	G			G		
	PN 16			Class 125		
	Ø K	Ø D	Number of holes L	Ø K	Ø D	Number of holes L
32 / NPS 1 1/4	100	140	4xØ19	88,9	140	4xØ15,7
40 / NPS 1 1/2	110	150	4xØ19	98,6	150	4xØ15,7
50 / NPS 2	125	165	4xØ19	120,7	165	4xØ19,1
65 / NPS 2 1/2	145	185	4xØ19	139,7	185	4xØ19,1
80 / NPS 3	160	200	8xØ19	152,4	200	4xØ19,1
100 / NPS 4	180	220	8xØ19	190,5	220	8xØ19,1
125 / NPS 5	210	250	8xØ19	-	-	-
150 / NPS 6	240	285	8xØ23	241,3	285	8xØ22,4
200 / NPS 8	295	340	12xØ23	298,5	340	8xØ22,4

Flange design by materials

Material variant	Standard	Nominal size	Pressure class
GG, GB, GC	EN 1092-2	DN 32 - DN 200	PN 16
	Drilled to ASME B16.1 ²⁶⁾	DN 32 - DN 100, DN 150 and DN 200	Class 125

²⁶⁾ DN 80 machined like DN 100

Installation types

Horizontal installation

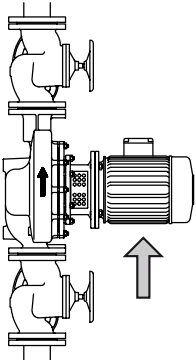

Fig. 8: Horizontal installation, direction of flow from bottom to top

i Motors of size 180 (18.5 kW) and above on pump sets with horizontal motor axis need to be supported adequately. Use the foot fastening holes at the motor housing for this purpose.

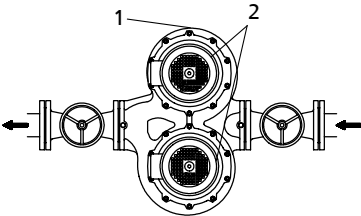

Fig. 9: Horizontal piping, 1 = screw plug 6D.1/2 and 2 = valve 5B.1/2

i To ensure trouble-free operation if the piping is laid horizontally, vent the upper pump through upper screw plug 6D.1/2 and valve 5B.1/2.

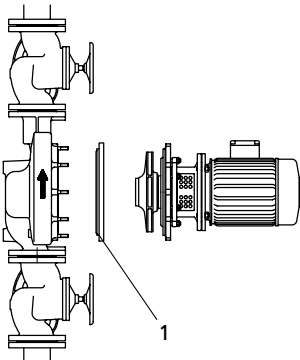

Fig. 10: Horizontal installation with blind flange (1 = blind flange, accessory)

i If one of the pumps needs to be serviced, shut the pump chamber off with a blind flange. The pump installation will remain functional.

Vertical installation

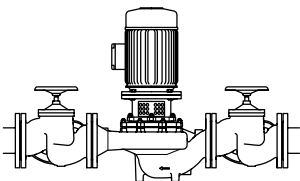

Fig. 11: Vertical installation / fastening without pump foot, sizes 032-032-160 to 080-080-250

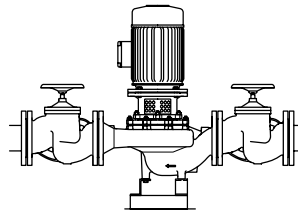

Fig. 12: Vertical installation / fastening with three angle feet (steel 37, accessories depend on the pump size), sizes 032-032-160 to 200-200-315

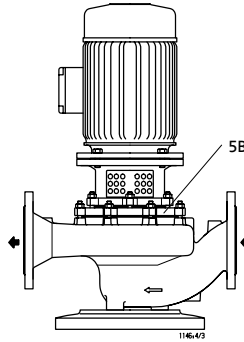

Fig. 13: Vertical installation, vent valve to prevent dry running of the mechanical seal

i For vertical installation with motor on top, use connection 5B for venting.

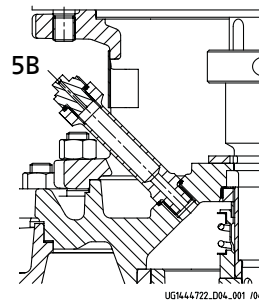



Fig. 14: Vent, mechanical seal chamber

i Use vent valve 5B for venting the mechanical seal chamber.

Accessories
Pump accessories

Pump accessories

Item	Description	Connection	Mat. No.	[kg]
-	Pump foot	Etaline Z 032-032-160 to 080-080-250 ²⁷⁾	47077960	1,5
-		Etaline Z 100-100-200 to 200-200-315 ²⁷⁾	47089180	3
	Blind flange with sealing element	Etaline Z 032/040/050/065/080/100-160, 100-125	01621012	6,7
		ETLZ 032/080/100/125/150-200, 125-160	01621013	12,4
		Etaline Z 040/050/0650/80/100/125/150/200-250	01621014	14,7
		Etaline Z 200-315	01621015	22,2

²⁷⁾ 3 pump feet with bolts

General assembly drawings

General assembly drawing with list of components

This view applies to the following pump sizes with bolted casing cover:

032-032-200 040-040-250 050-050-250 065-065-250 080-080-250 100-100-250 125-125-250 150-150-250 200-200-250
200-200-315

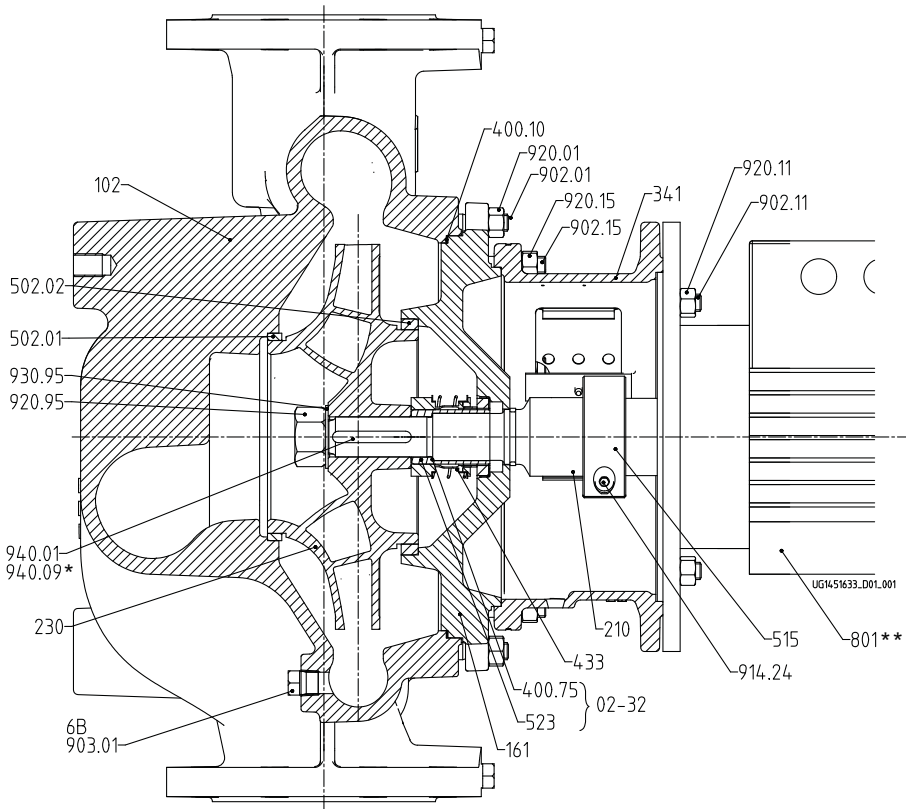

Fig. 15: General assembly drawing (* Second key for WS 55 only; ** With motor foot from motor size 132)

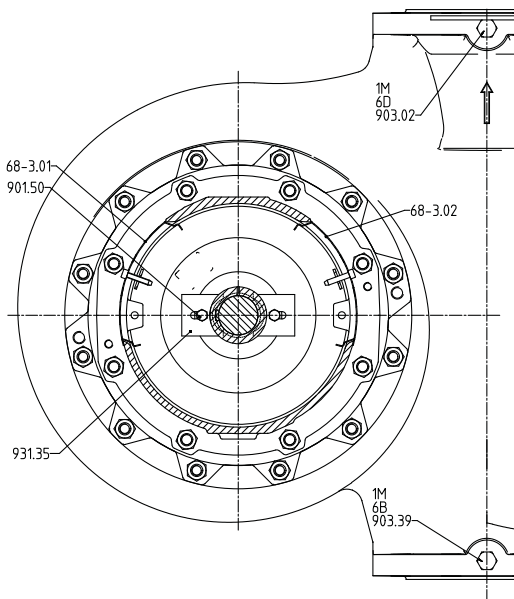
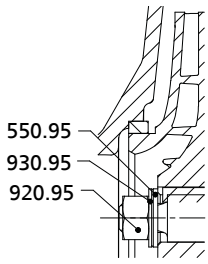
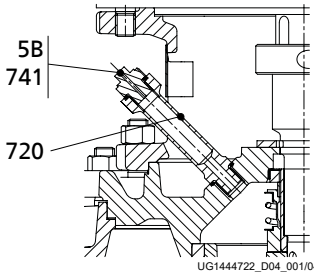

Fig. 16: General assembly drawing: side view

Fig. 17: Fastening elements for the impeller, WS 25

Fig. 18: Vent valve 5B

This view applies to the following pump sizes with clamped casing cover:

032-032-160

040-040-160

050-050-160

065-065-160

080-080-160

100-100-200

125-125-200

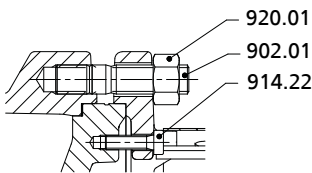
Fig. 19: Fastening elements for the clamped casing cover

List of components

Part No.	Description	Part No.	Description
02-32	Spare shaft protecting sleeve/ gasket assembly	68-3.01/02	Cover plate
102	Volute casing	720	Fitting
161	Casing cover	741	Vent valve
210	Shaft	801	Flanged motor
230	Impeller	901.50	Hexagon head bolt
341	Drive lantern	902.01/11/15	Stud
400.10/75	Gasket	903.01/02/39	Screw plug
433	Mechanical seal	914.22/24	Hexagon socket head cap screw
502.01/02	Casing wear ring	920.01/11/15/95	Hexagon nut
515	Locking ring	930.95	Safety device
523	Shaft sleeve	931.35	Lock washer
550.95	Disc ²⁸⁾	940.01/09	Key

Connections

Part No.	Description	Part No.	Description
1M	Pressure gauge	6B	Fluid drain
5B	Vent, mechanical seal chamber	6D	Fluid priming and venting

²⁸⁾ For shaft unit 25 only

Glossary

ACS

French drinking water regulations (ACS = Attestation de Conformité Sanitaire)

Back pull-out design

The complete back pull-out unit can be pulled out without having to remove the pump casing from the piping.

Close-coupled design

Motor directly fitted to the pump via a flange or a drive lantern

IE1

Efficiency class to IEC 60034-30: 1 = Standard Efficiency (IE = International Efficiency)

IE2

Efficiency class to IEC 60034-30: 2 = High Efficiency (IE = International Efficiency)

IE3

Efficiency class to IEC 60034-30: 3 = Premium Efficiency (IE = International Efficiency)

IE4

Efficiency class to IEC TS 60034-30-2:2016 = Super Premium Efficiency (IE = International Efficiency)

IE5

Efficiency class to IEC TS 60034-30-2:2016 = Ultra Premium Efficiency (IE = International Efficiency)

In-line design

A pump whose suction and discharge nozzle are arranged opposite each other and have the same nominal diameter.

Mat. No.

This identification number is composed of an 8-digit numerical code that uniquely identifies a product entered in SAP.

Mech. seal

Mechanical seal

SU

Shaft unit

UBA

German drinking water regulations to German Environment Agency

WRAS

Approved by all water suppliers in the UK (WRAS = Water Regulations Advisory Scheme)



KSB SE & Co. KGaA
Johann-Klein-Straße 9 • 67227 Frankenthal (Germany)
Tel. +49 6233 86-0
www.ksb.com