

END SUCTION CENTRIFUGAL PUMPS

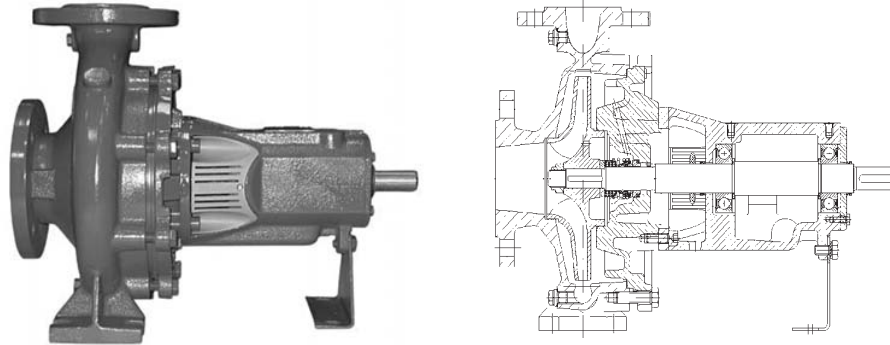

EBARA ENR pump is designed for pumping water or fluid according to DIN 24255 (EN733) standard. The B.P.O design of the pump allows the complete drive unit to be removed from the casing without disturbing the attached pipe work.

FEATURES OF ENR

- Single-stage end suction centrifugal pump
- Volute pump casing with cast pump feet
- Bearing support with foot
- Axial suction and radial discharge upwards
- Totally enclosed radial impeller
- Hydraulic balance by means of wearing ring and balancing holes
- Lifetime lubricated ball bearings
- Mechanical shaft seal according to DIN 24960. (Gland packing optional)

APPLICATIONS

- Water supply duties for municipalities and industries
- Irrigation
- Drainage
- Heating and air-conditioning
- Hot and chilled water
- Fresh and sea water
- Fire protection

SPECIFICATIONS

Range	Maximum speed	3600 rpm	
	Maximum capacity	2000 m ³ /h	
	Maximum pressure	150 m	
Fluids	Characteristics	Clean fluids	
	Maximum temperature	-20°C ~ +120°C	+120°C ~ +170°C
	Maximum working pressure	16 / 10 ⁽¹⁾ / 14 ⁽²⁾ bar	14 / 9 ⁽¹⁾ / 8 ⁽²⁾ bar
Materials	Casing	Cast iron GG-25	
	Impeller	Cast iron GG-25	Bronze G-CuSn 10
	Shaft	AISI 420 Stainless Steel 1.4021	
	Shaft sleeve	AISI 420 Stainless Steel 1.4021	
	Mechanical seal	Silicon Carbide / Carcon - EPDM ⁽³⁾	
	Bearing	Lifetime Lubricated Ball Bearings	
Drive	Motor	Electric, Engine, Steam Turbine	

*From size 80-400 up to 300-500, except 150-500. *Size 150-500. *Check operating limits depending on pumped fluid

SELECTION CHART

SELECTION CHART at 1450 r.p.m.

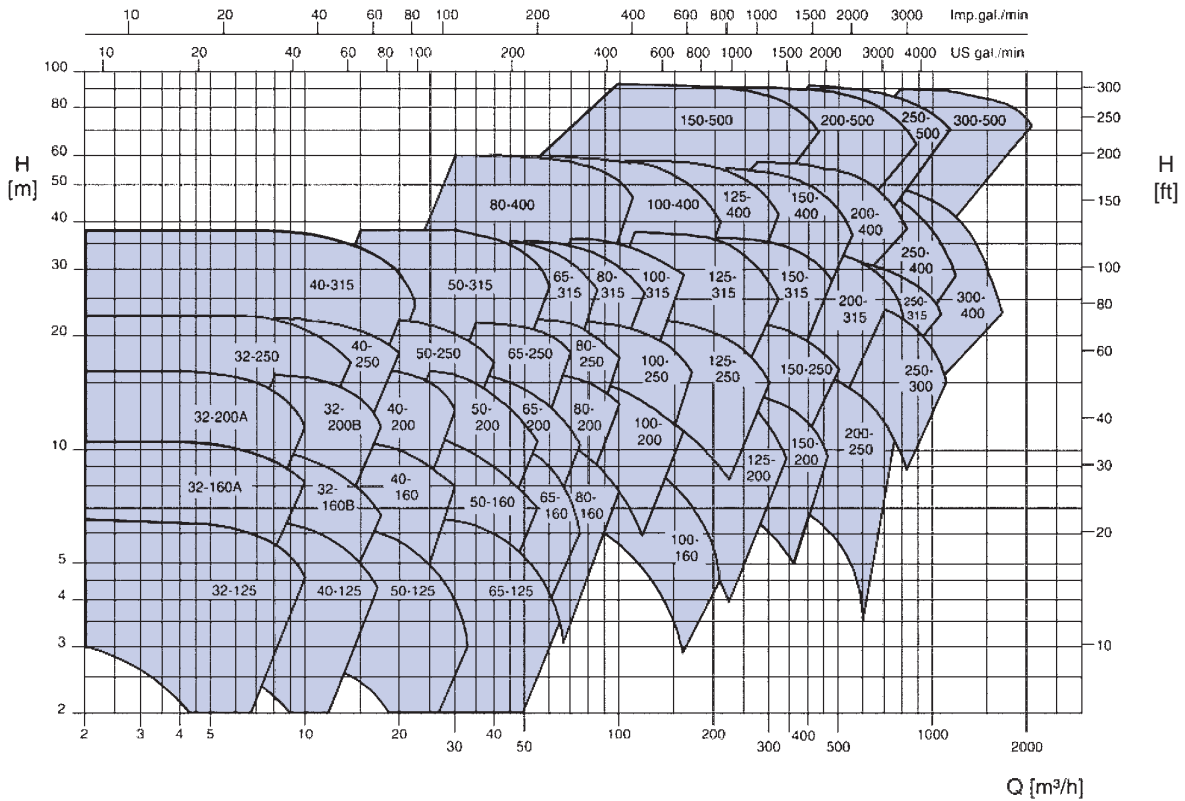

SELECTION CHART at 2900 r.p.m.

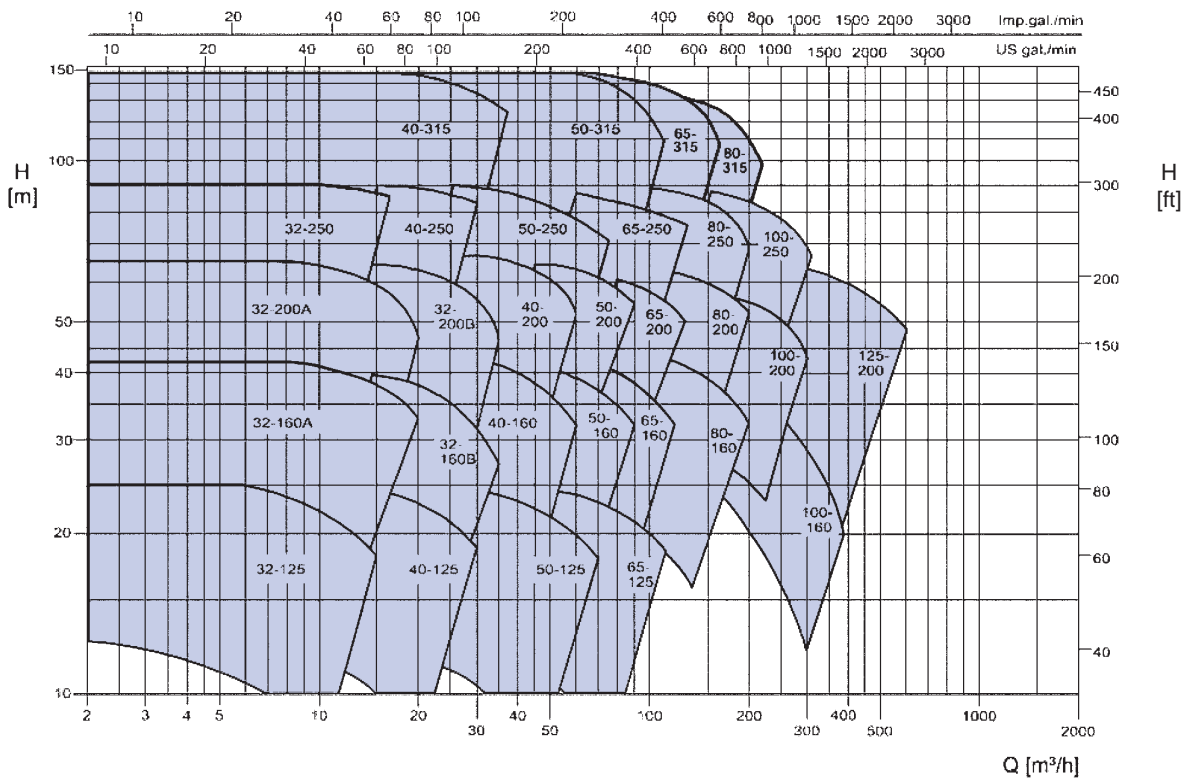

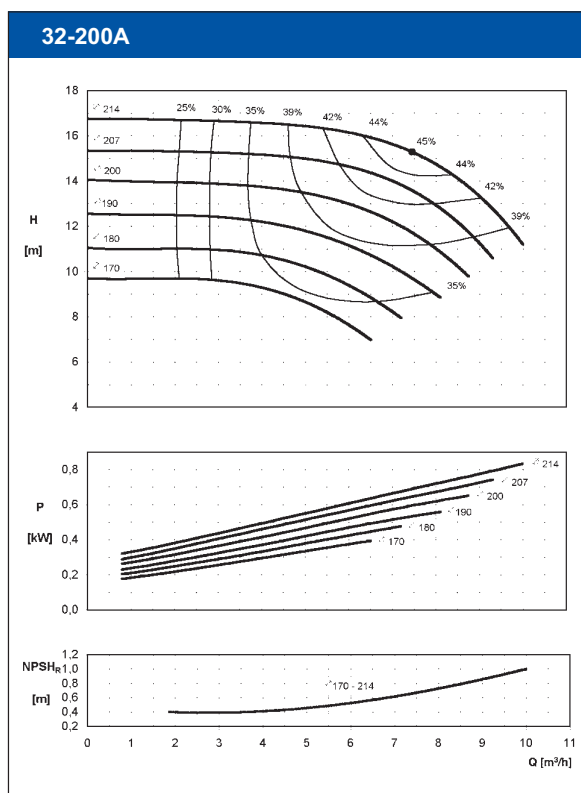
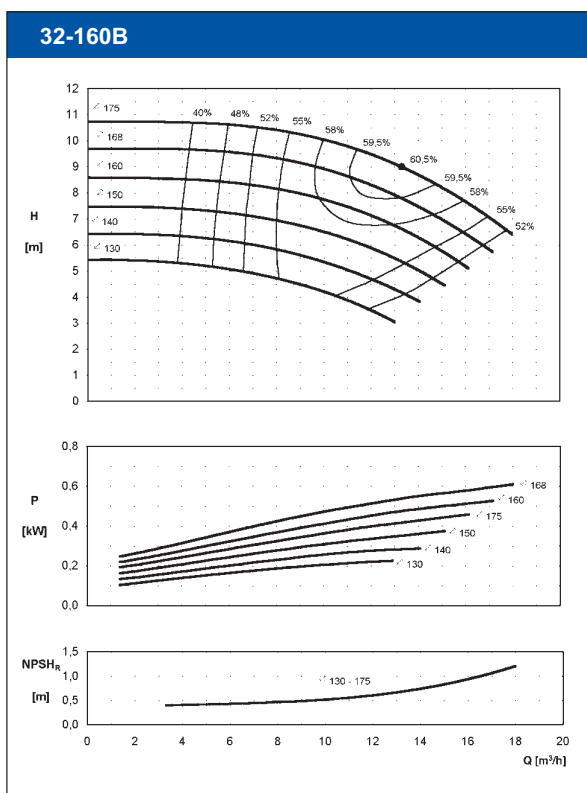
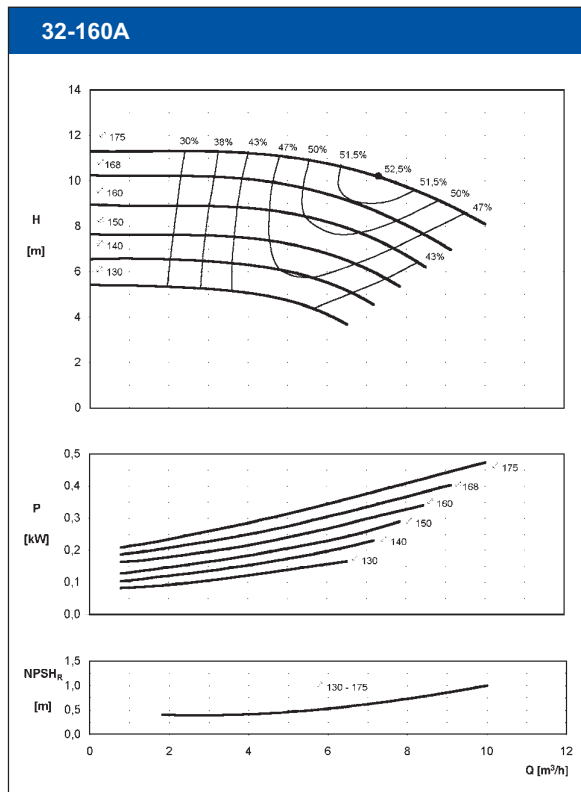
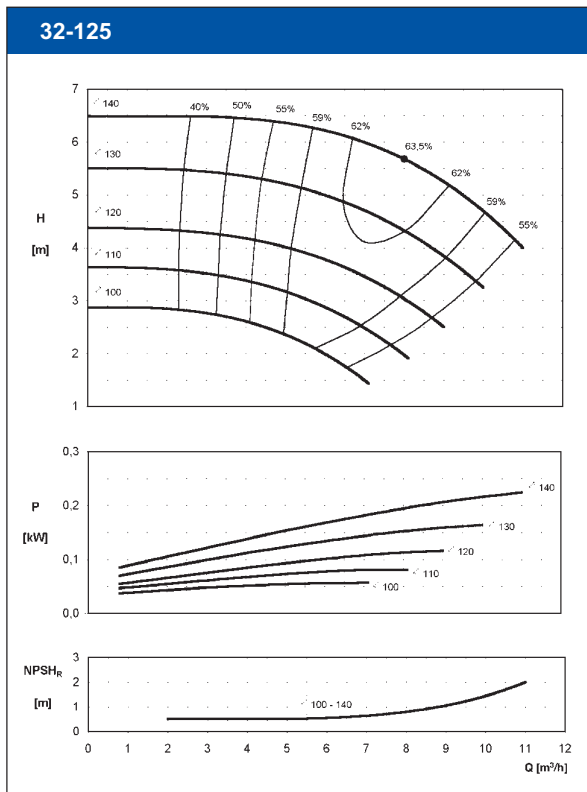
PERFORMANCE CURVE
1450 r.p.m.

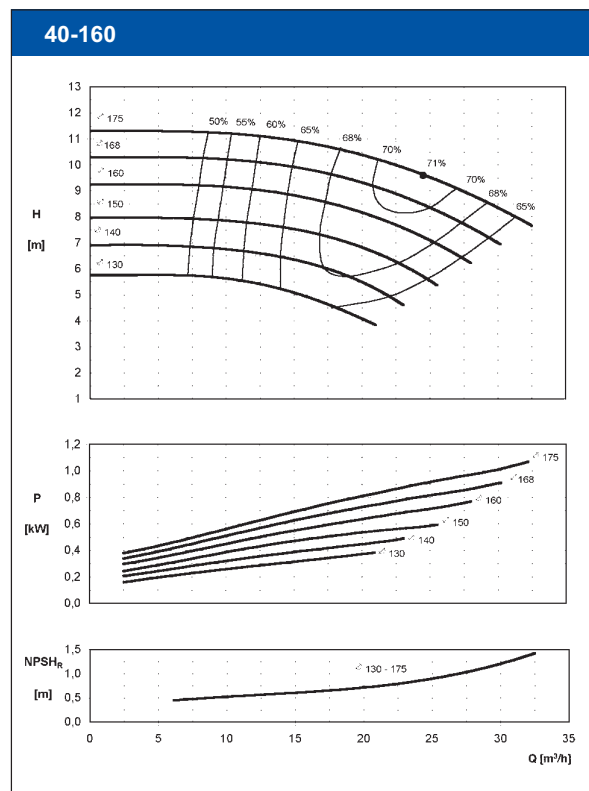
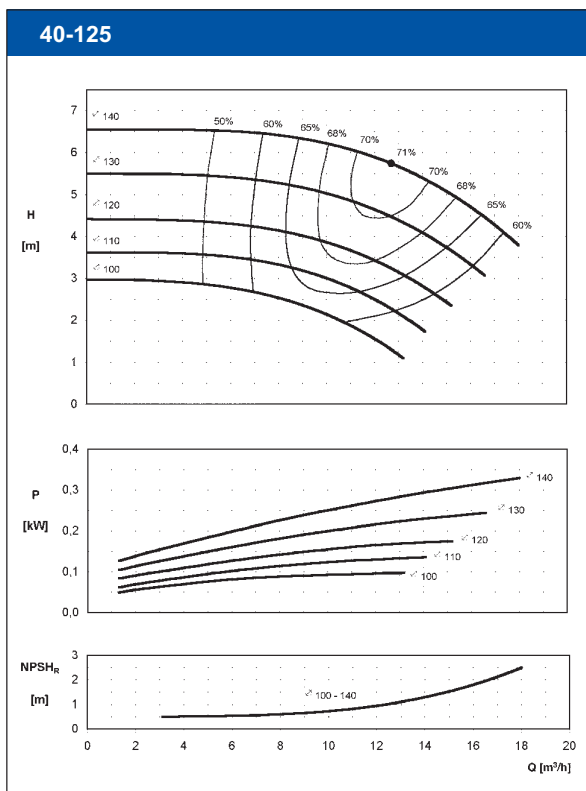
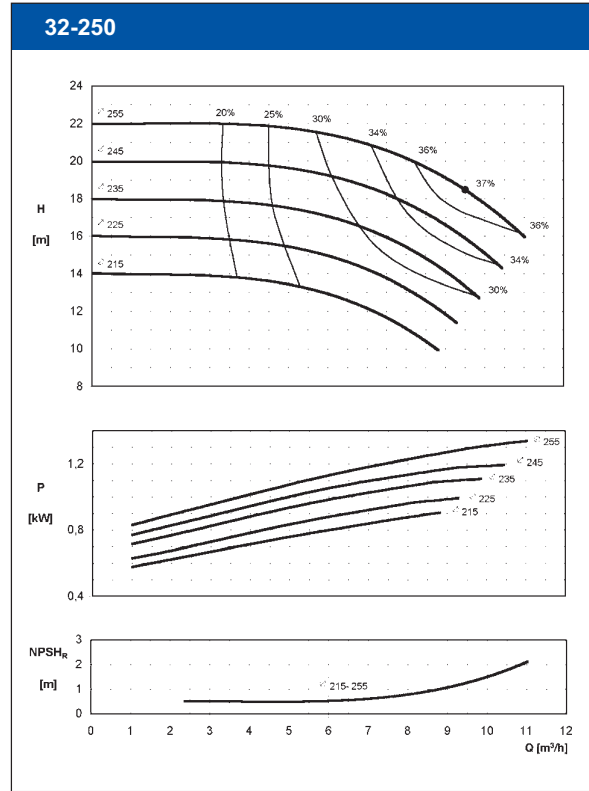
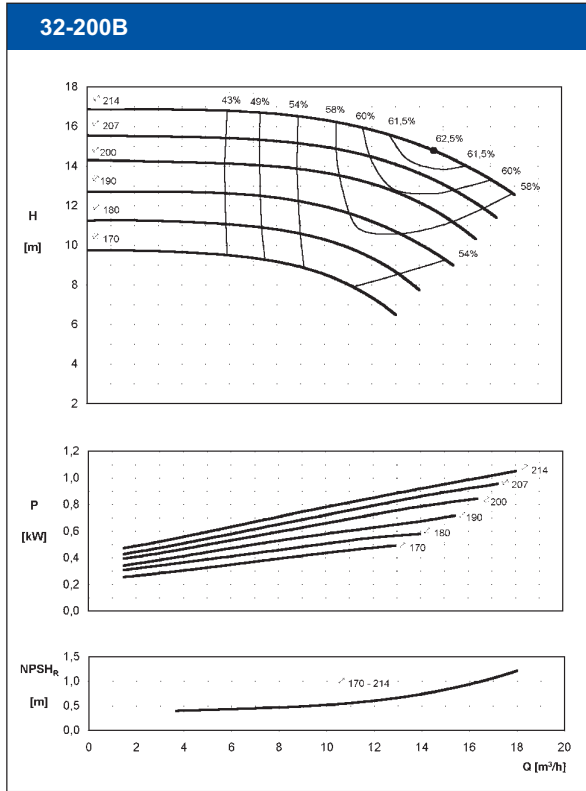
PERFORMANCE CURVE
1450 r.p.m.

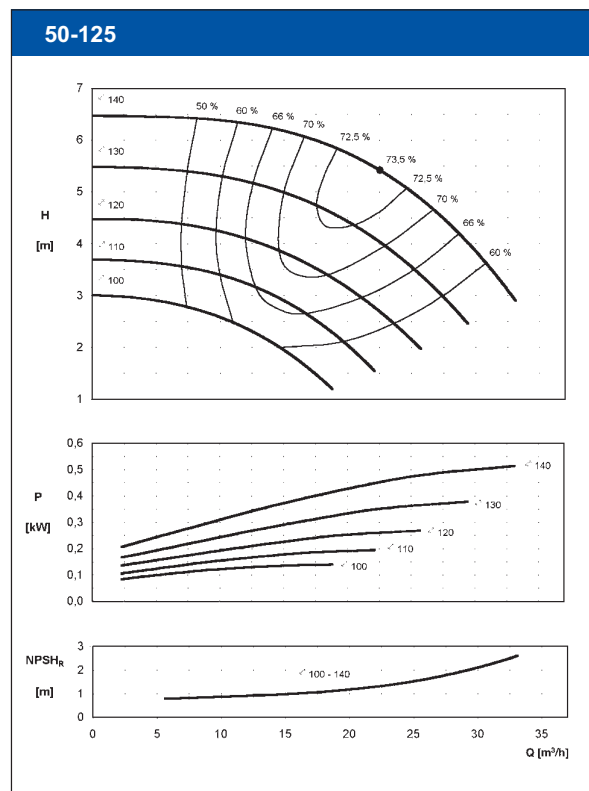
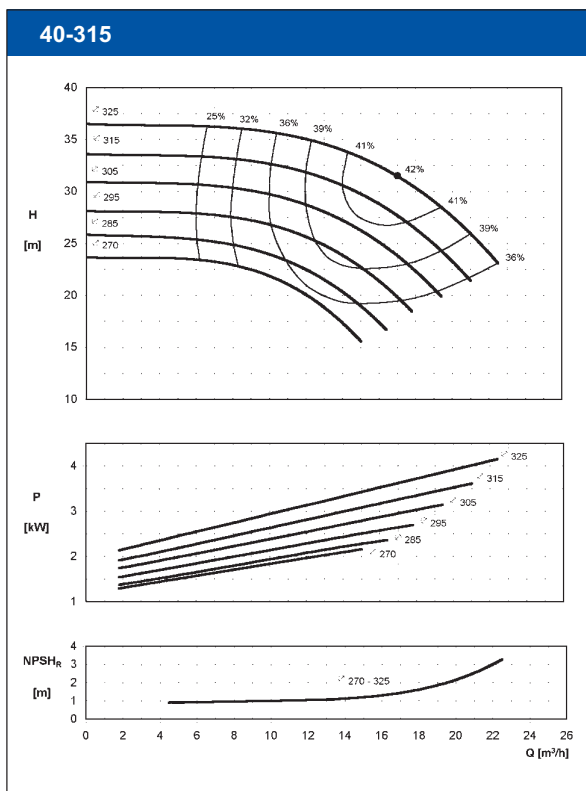
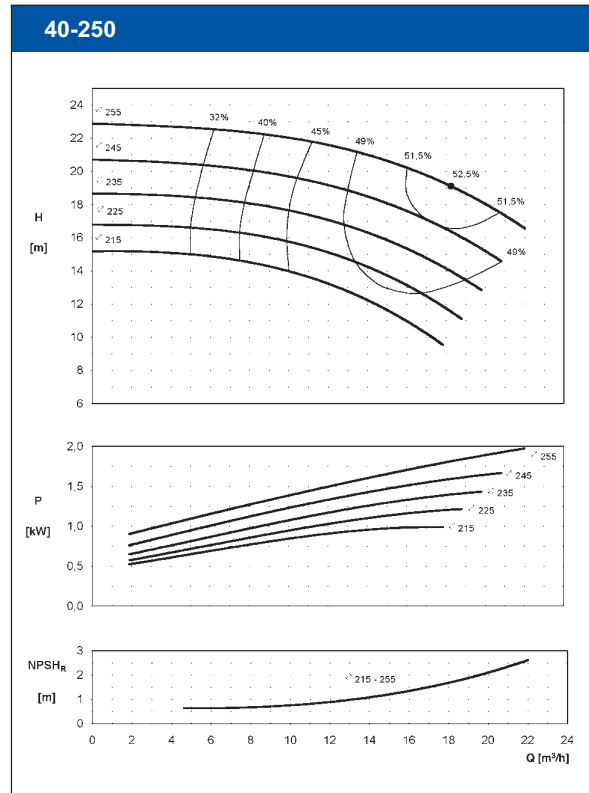
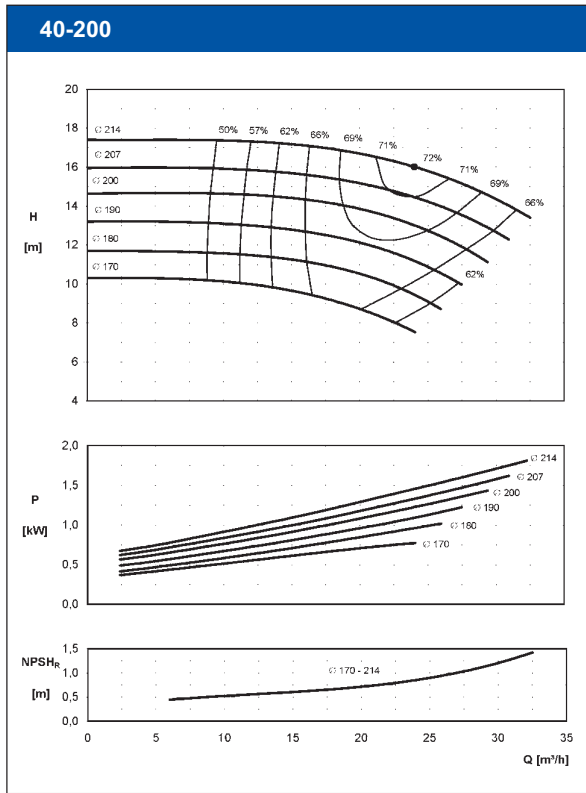
PERFORMANCE CURVE
1450 r.p.m.

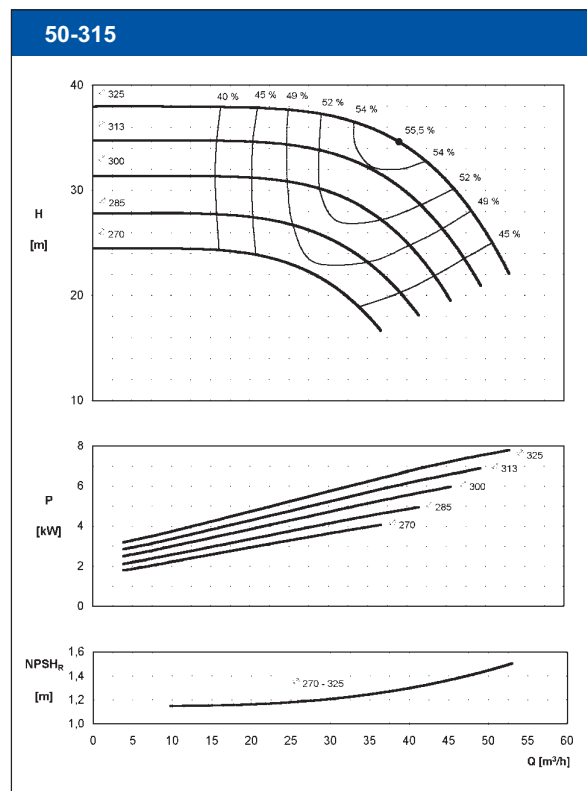
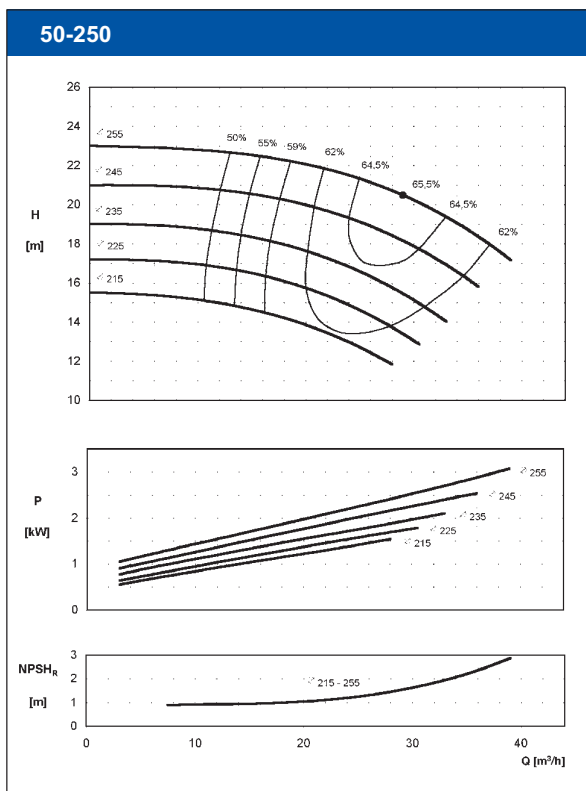
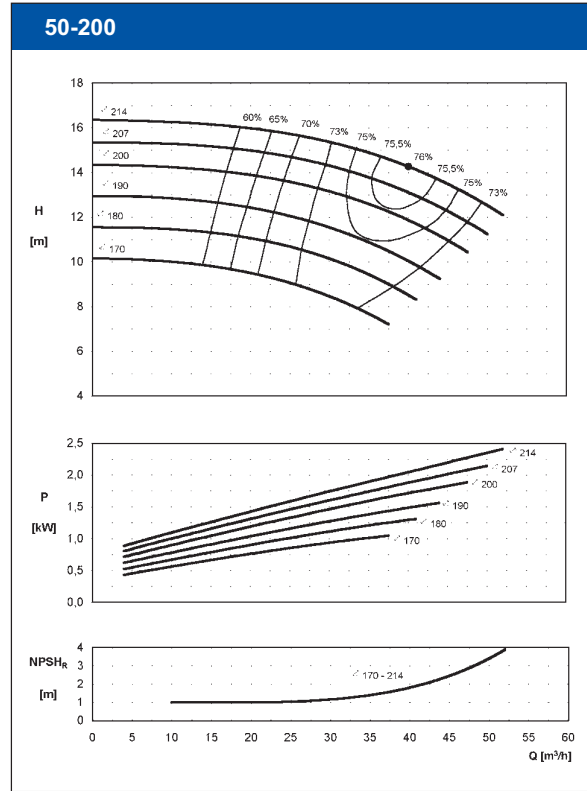
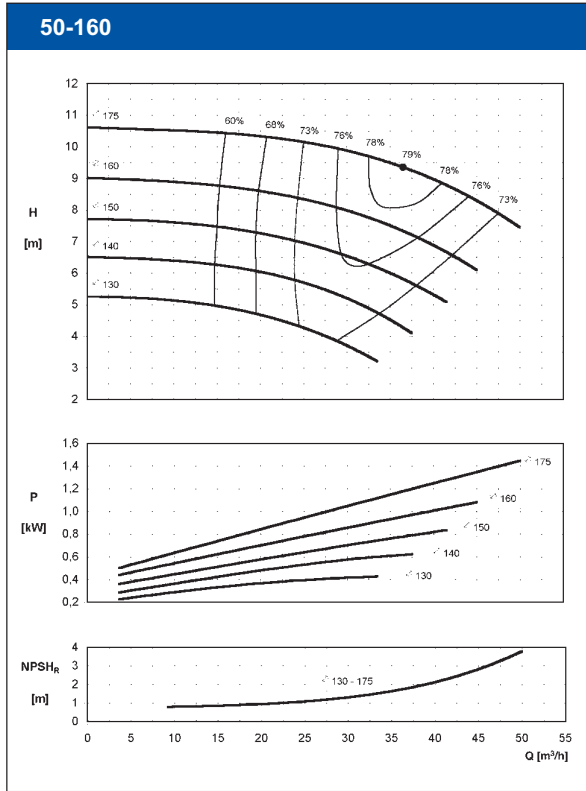
PERFORMANCE CURVE
1450 r.p.m.

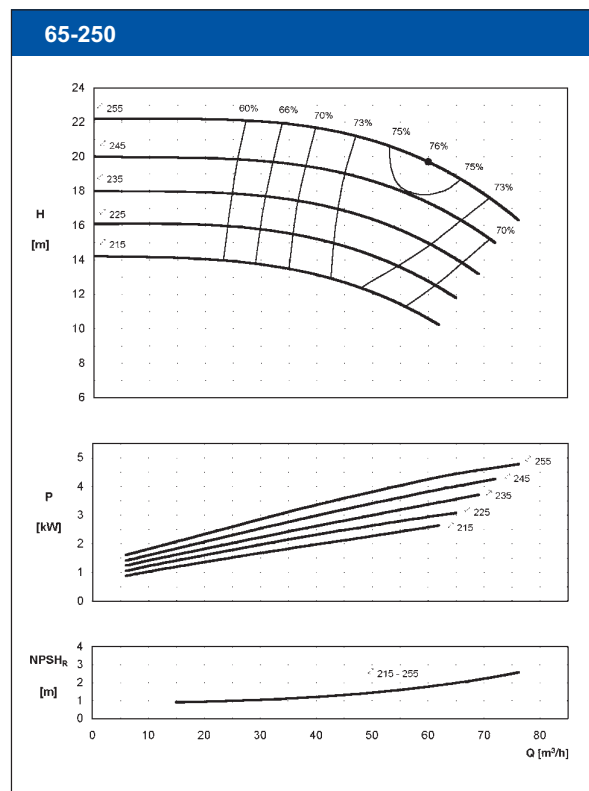
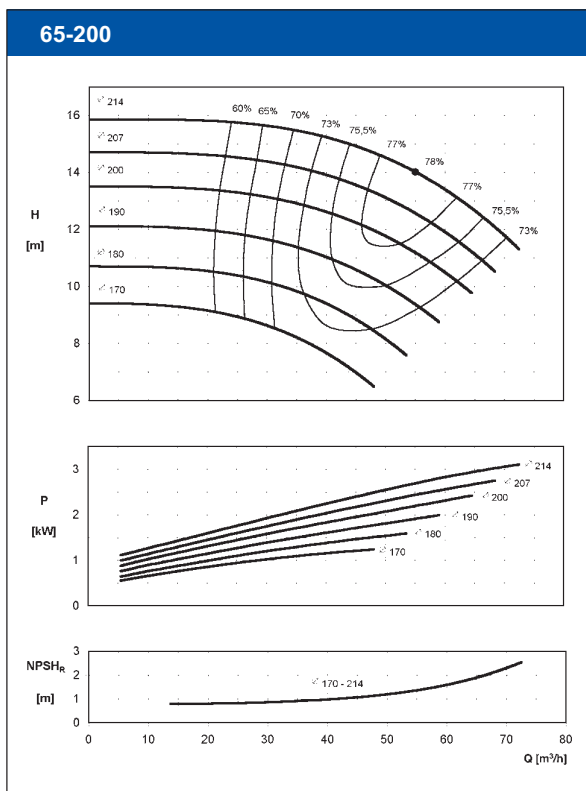
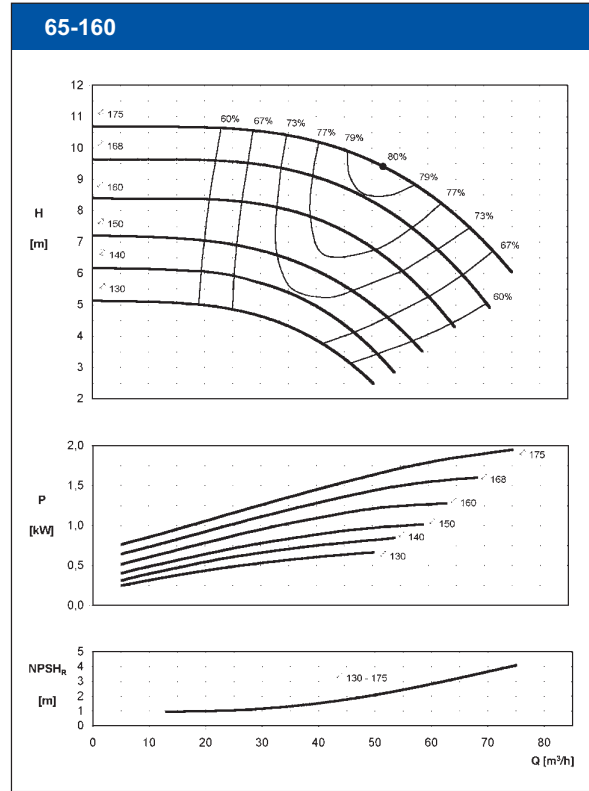
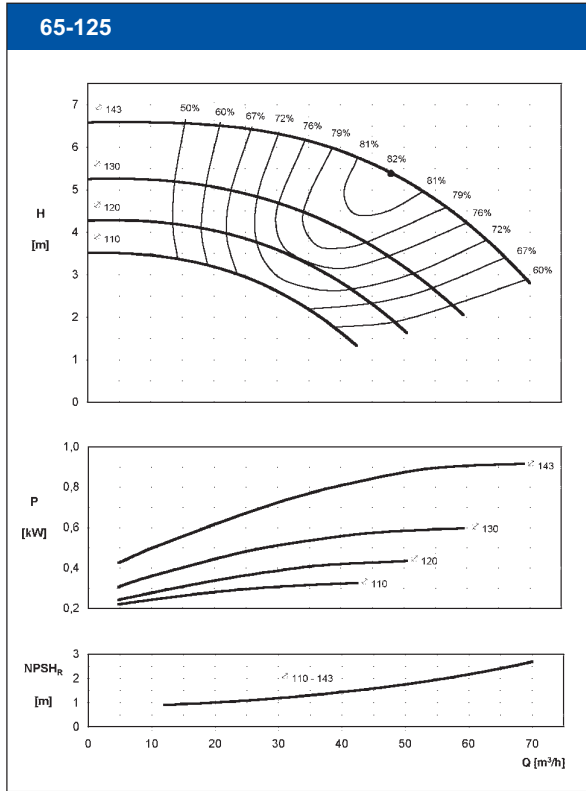
PERFORMANCE CURVE
1450 r.p.m.

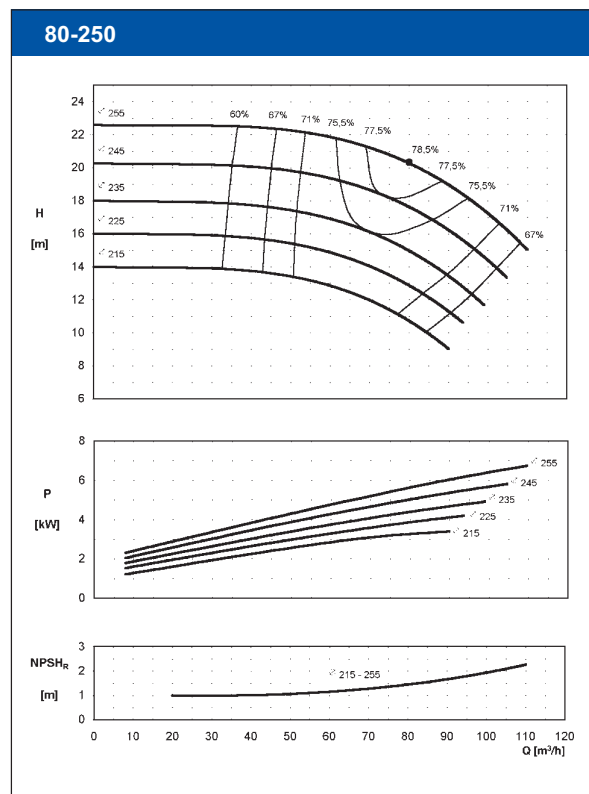
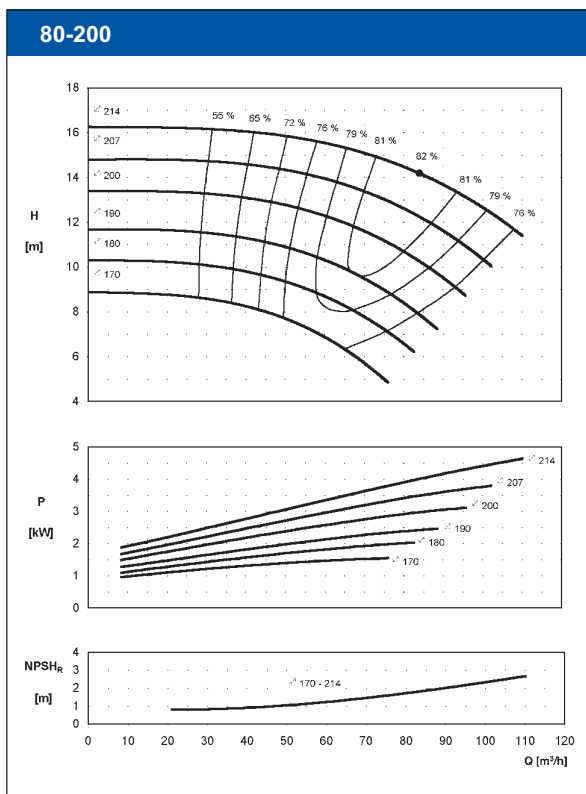
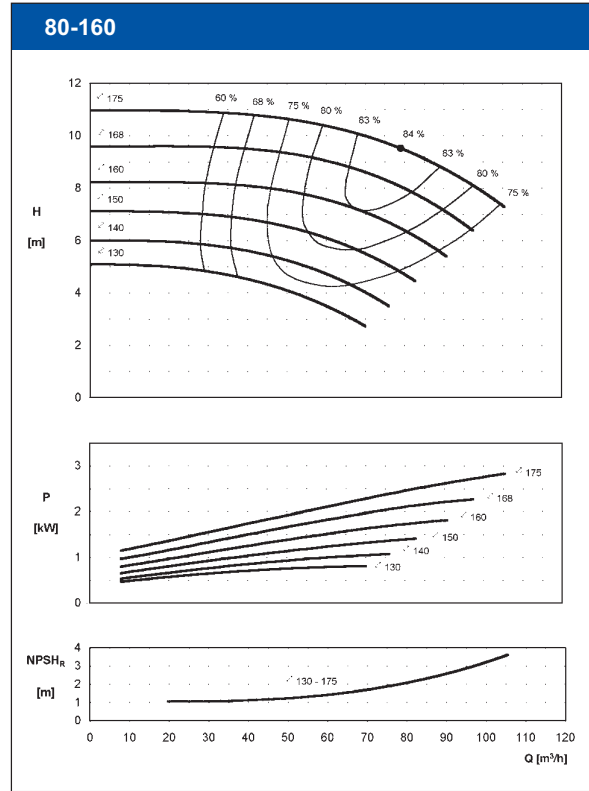
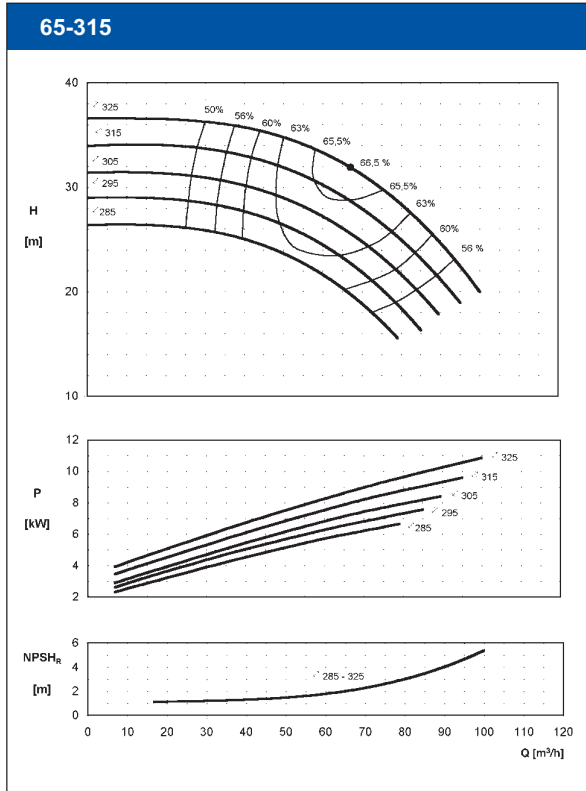
PERFORMANCE CURVE
1450 r.p.m.

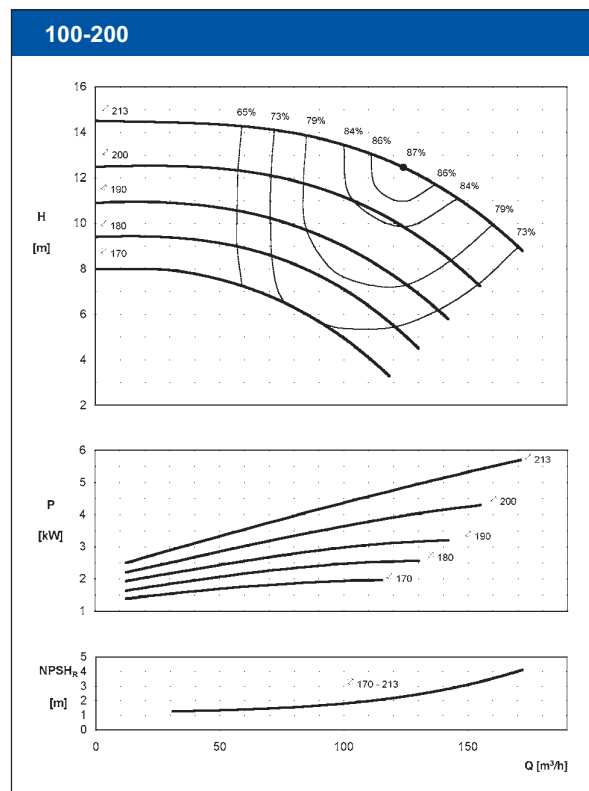
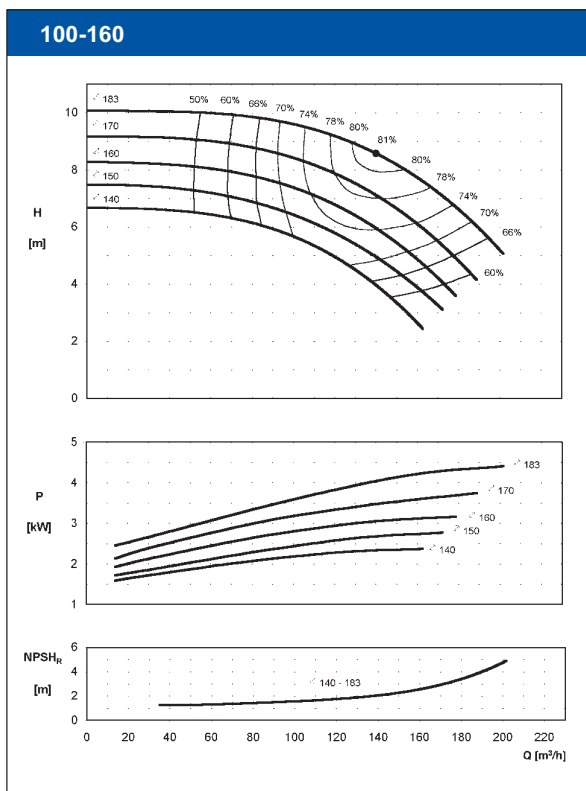
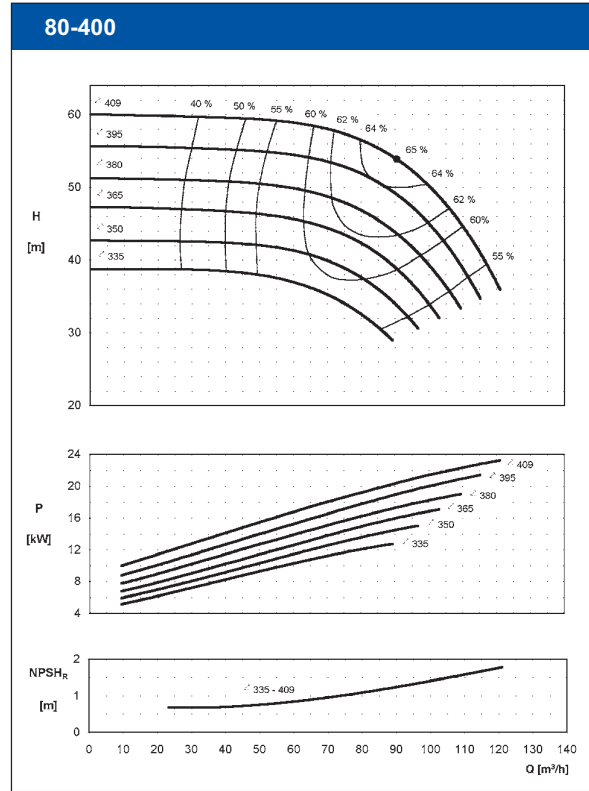
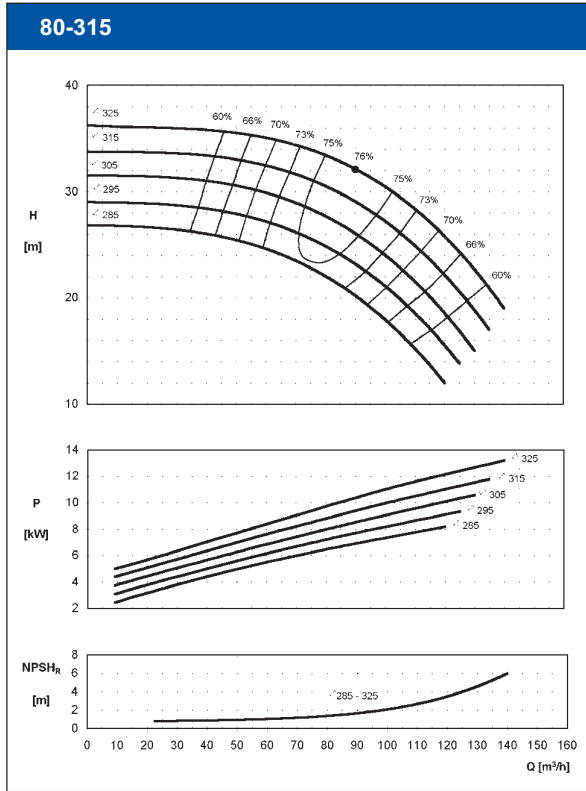
PERFORMANCE CURVE
1450 r.p.m.

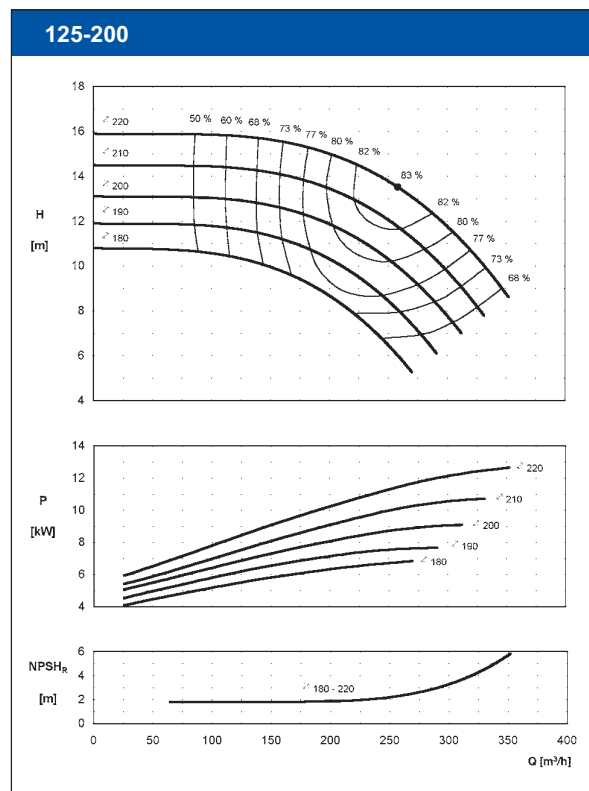
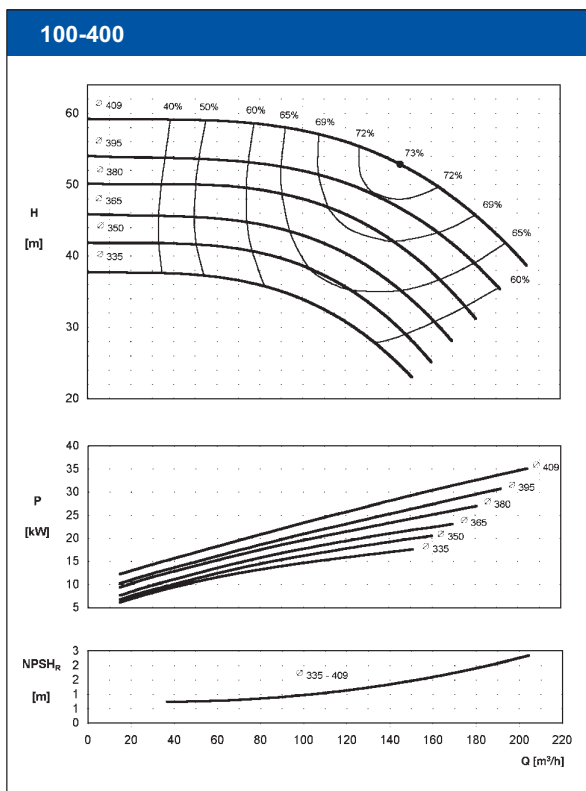
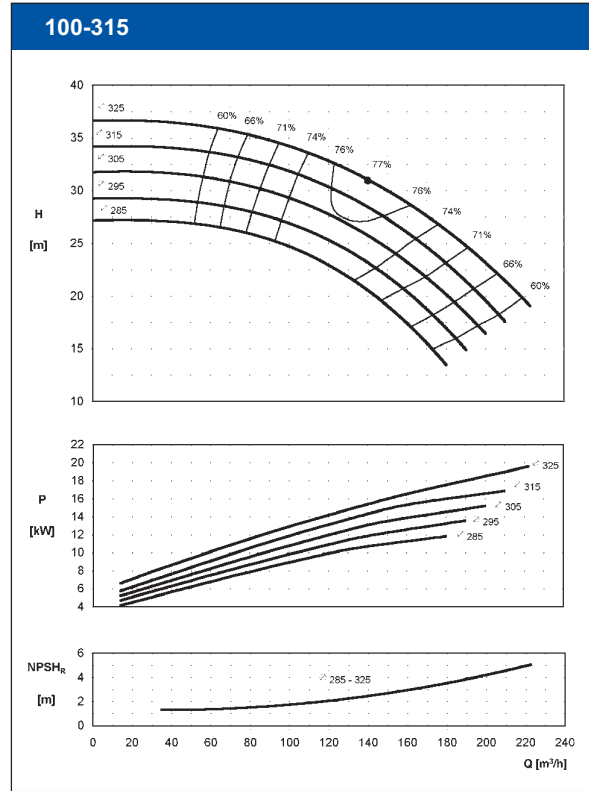
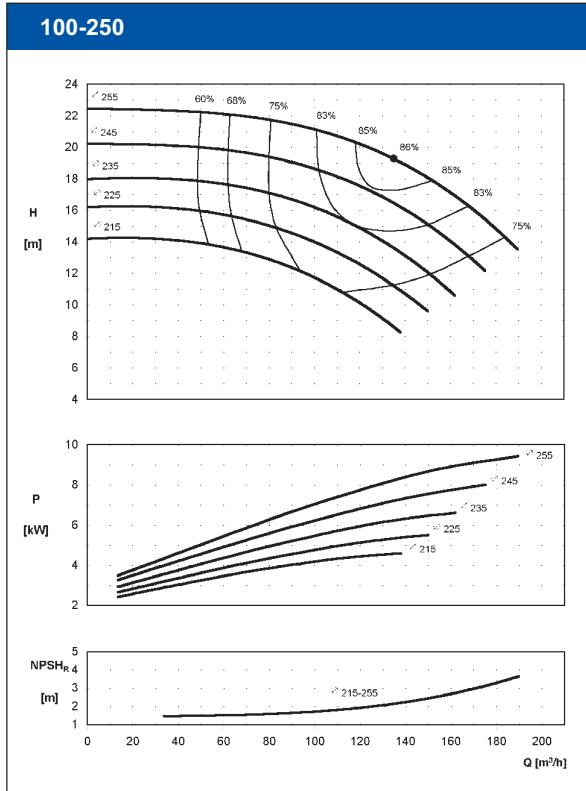
PERFORMANCE CURVE
1450 r.p.m.

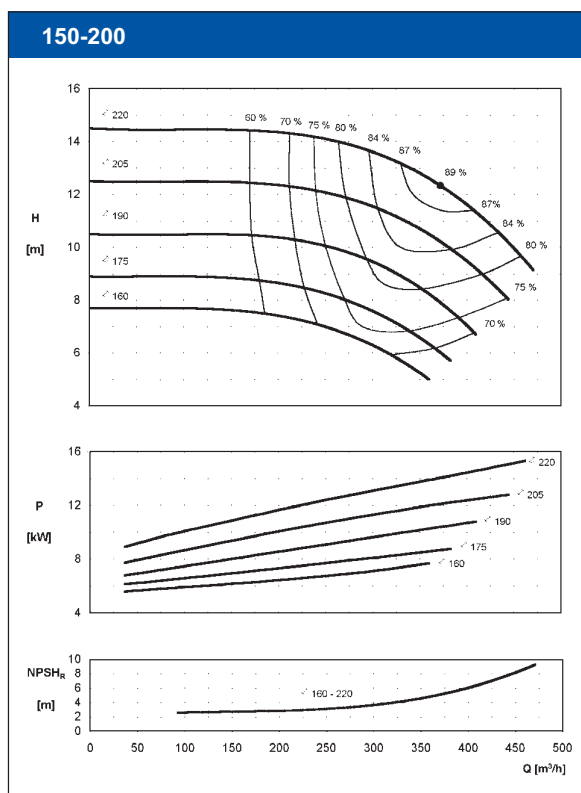
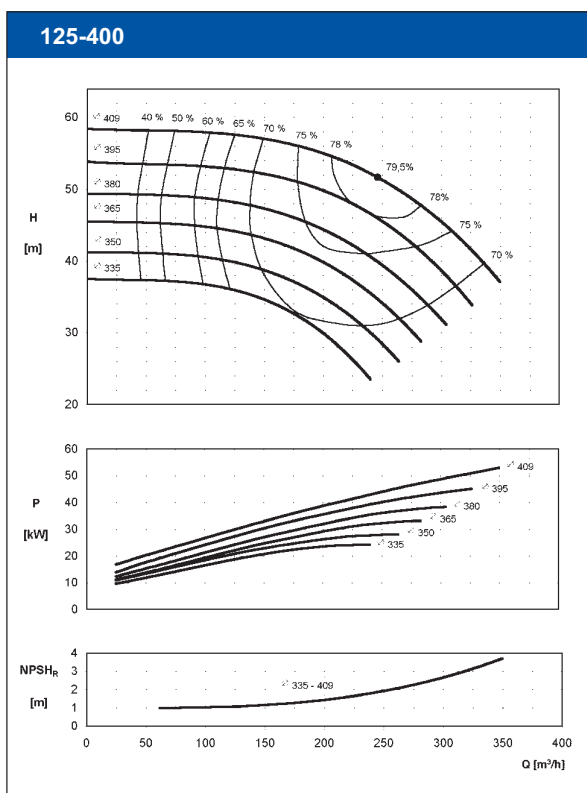
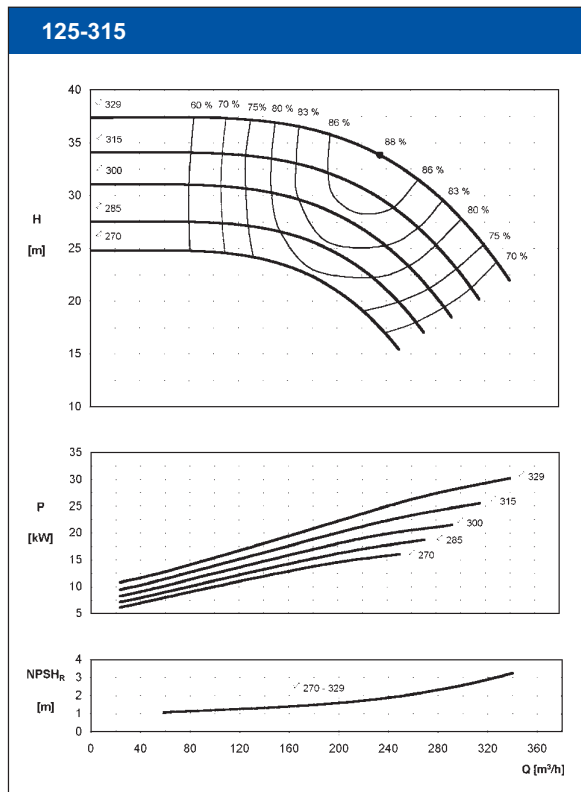
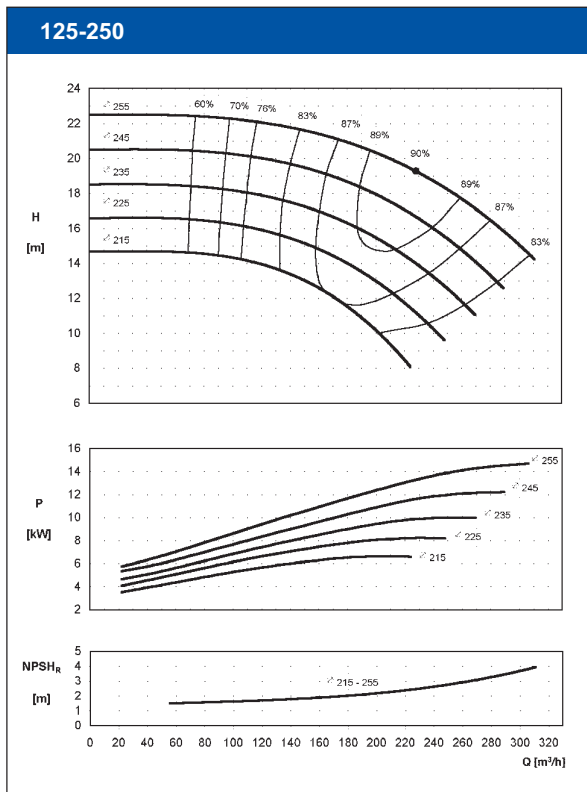
PERFORMANCE CURVE
1450 r.p.m.

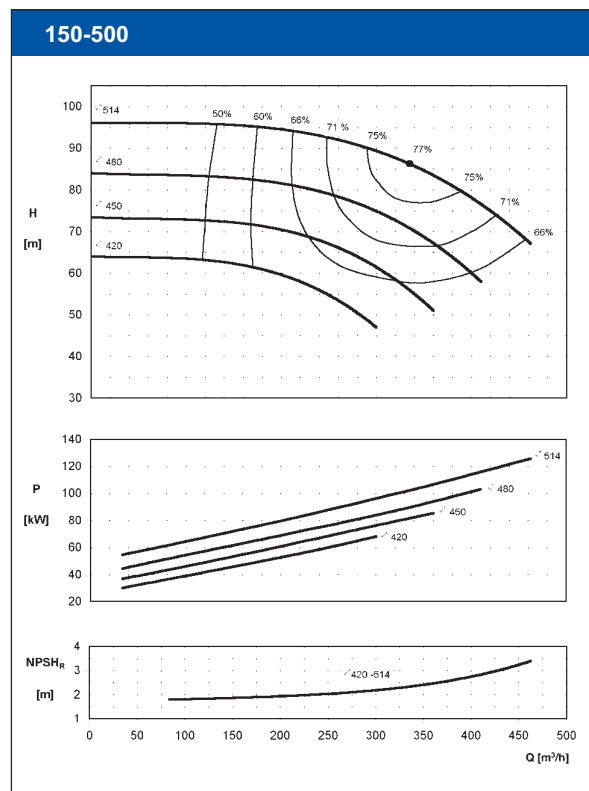
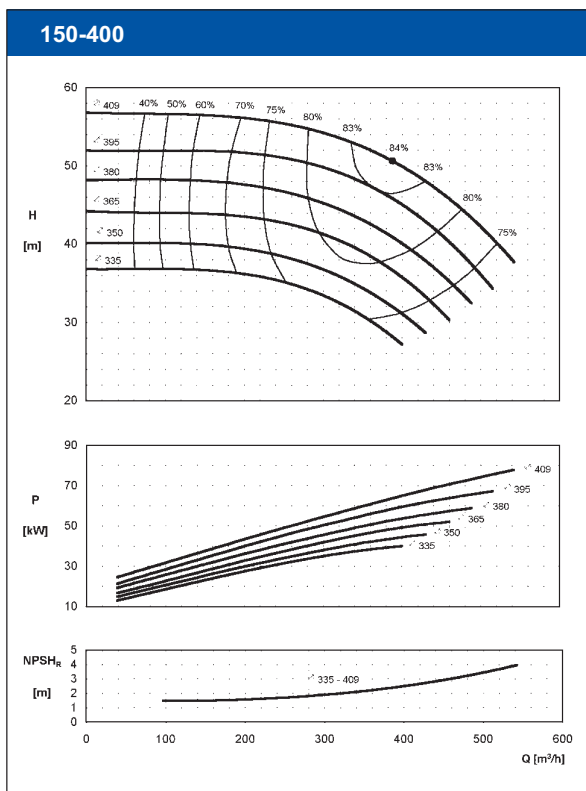
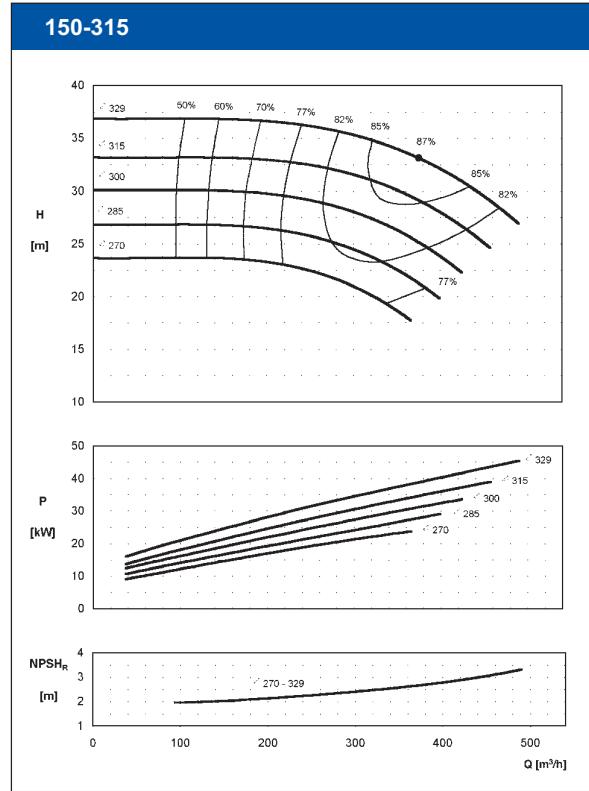
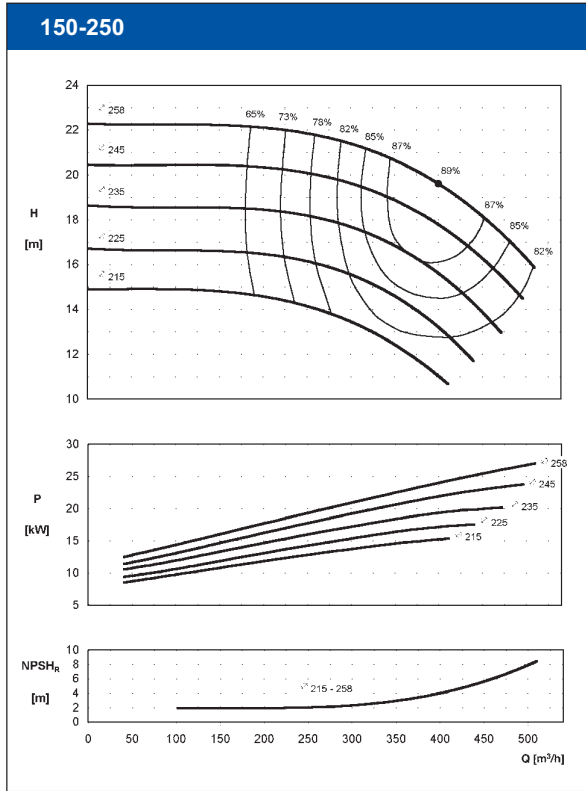
PERFORMANCE CURVE
1450 r.p.m.

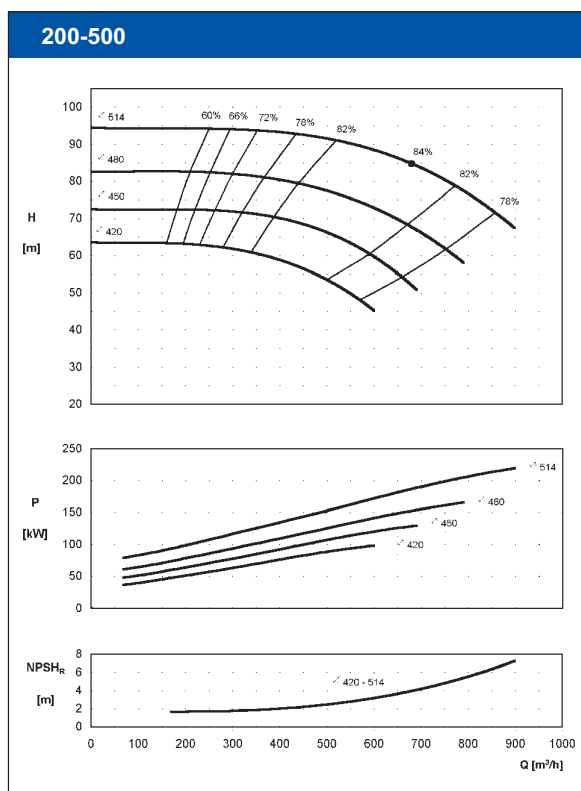
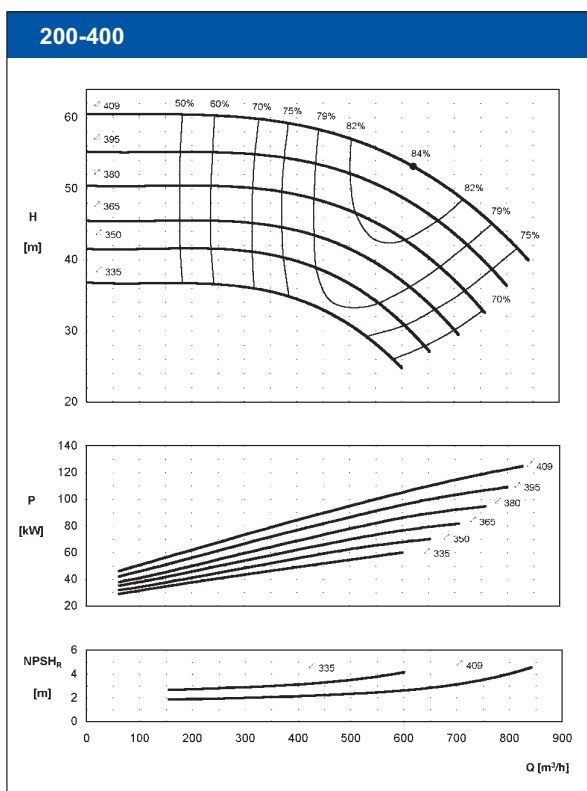
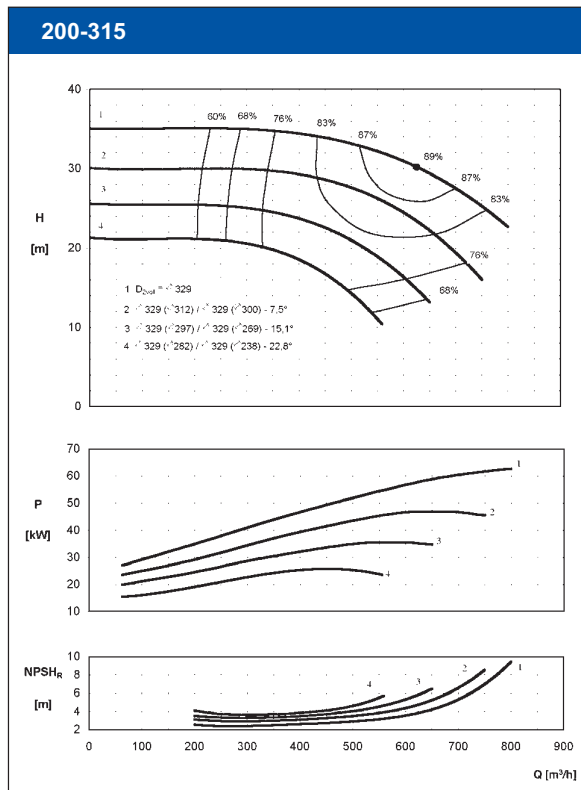
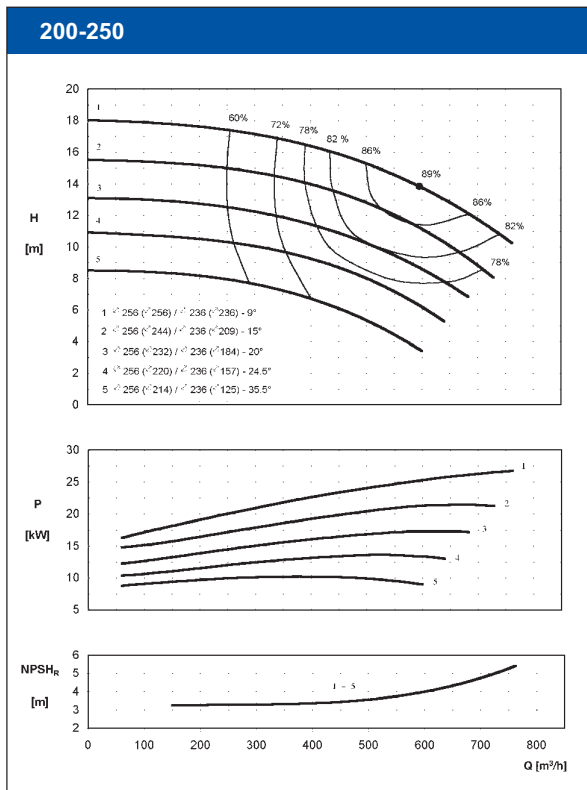
PERFORMANCE CURVE
1450 r.p.m.

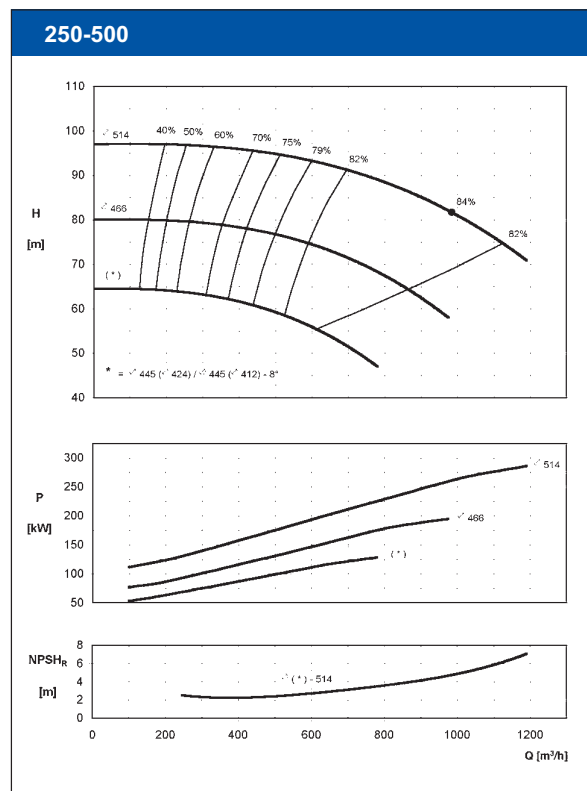
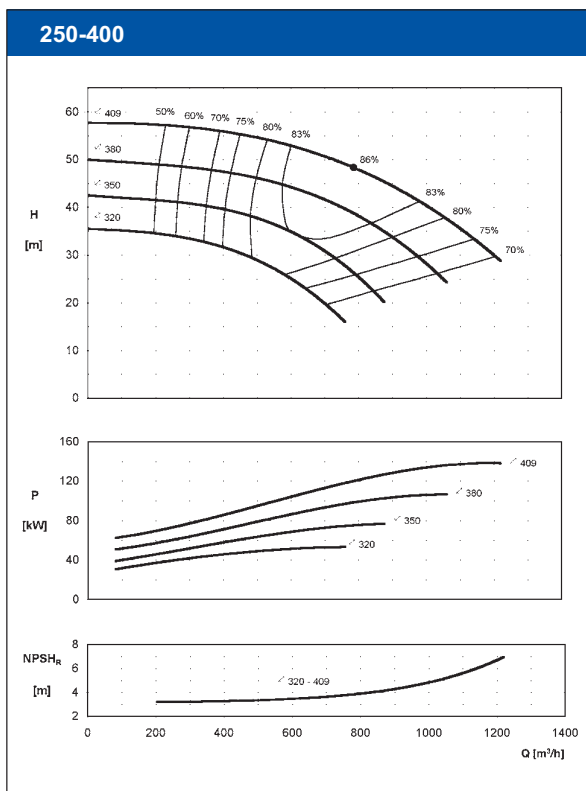
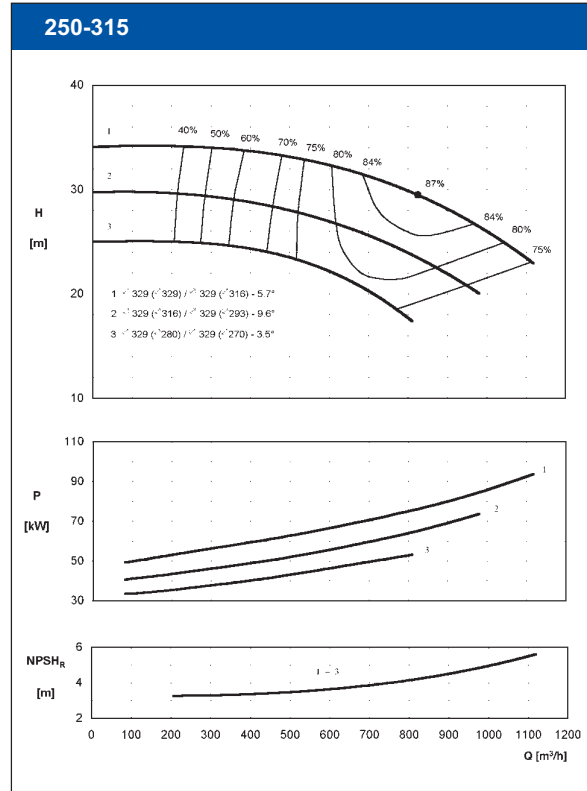
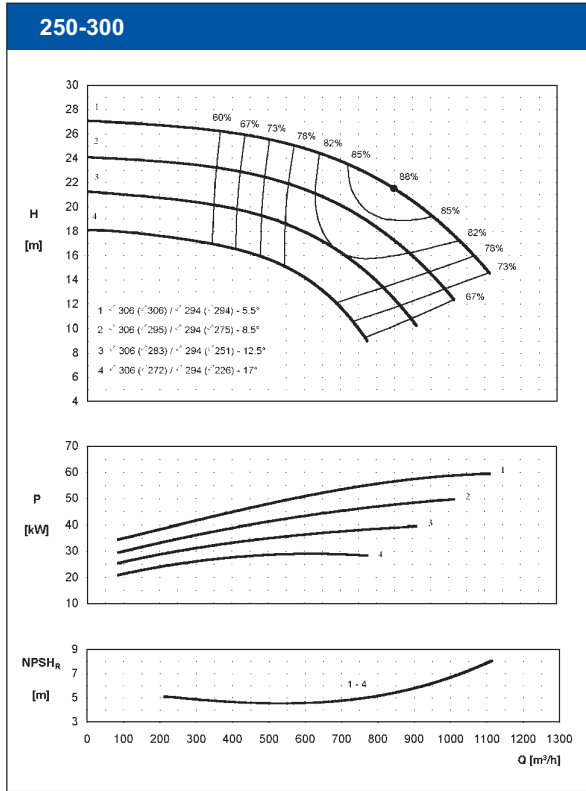
PERFORMANCE CURVE
1450 r.p.m.

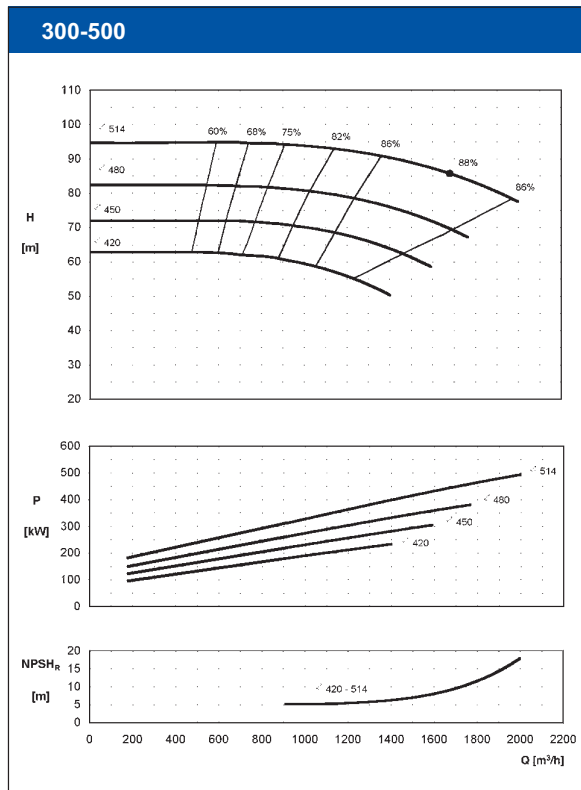
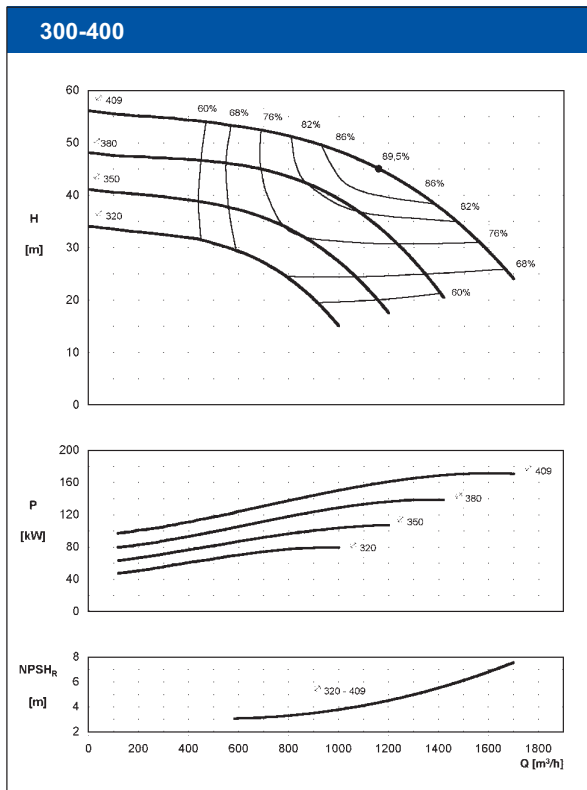
PERFORMANCE CURVE
1450 r.p.m.

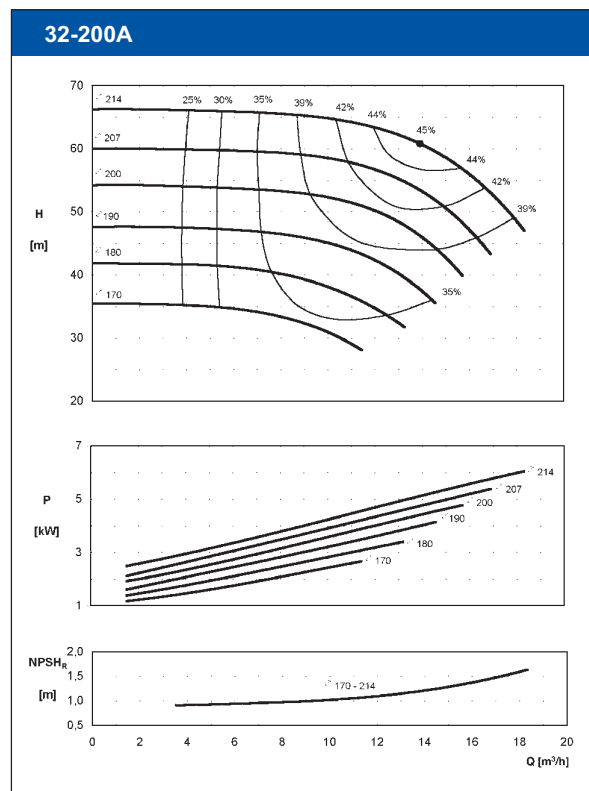
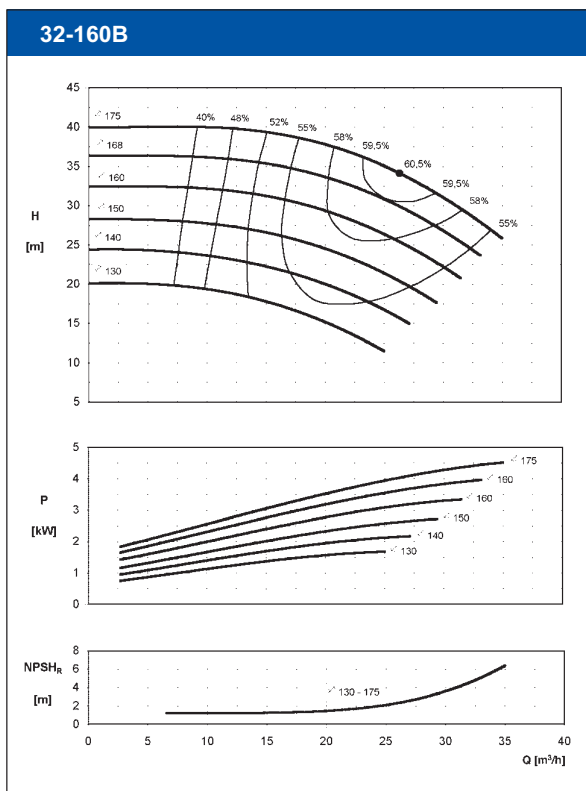
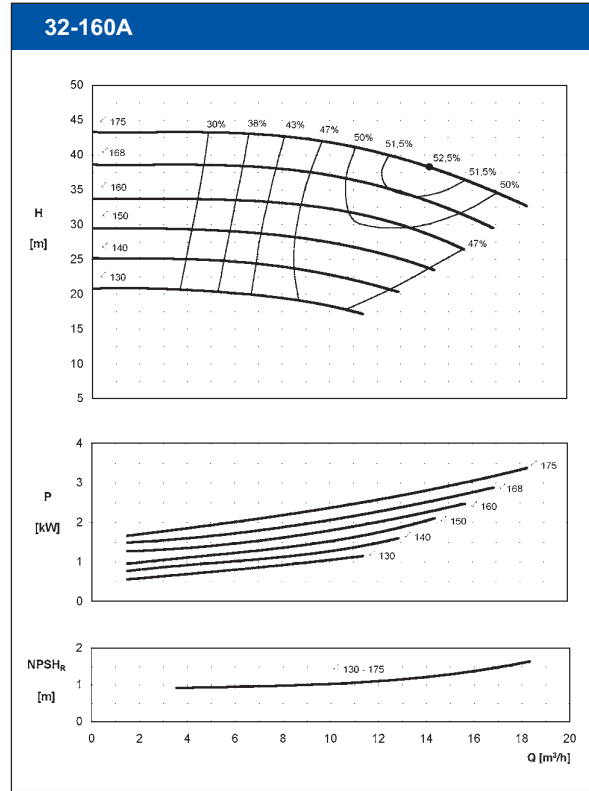
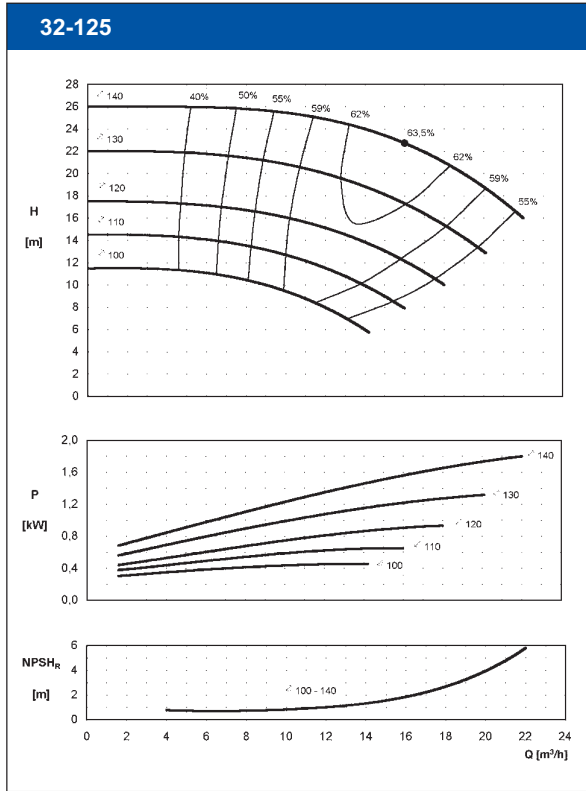
PERFORMANCE CURVE
2900 r.p.m.

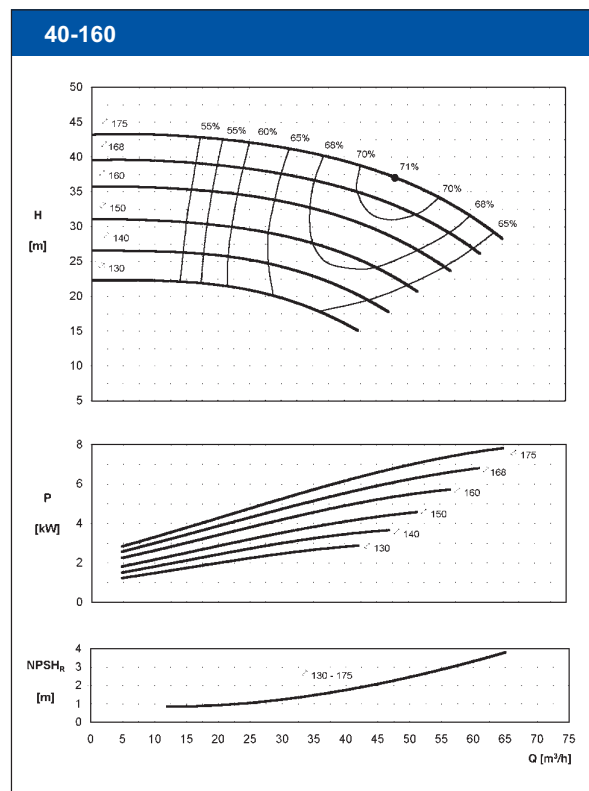
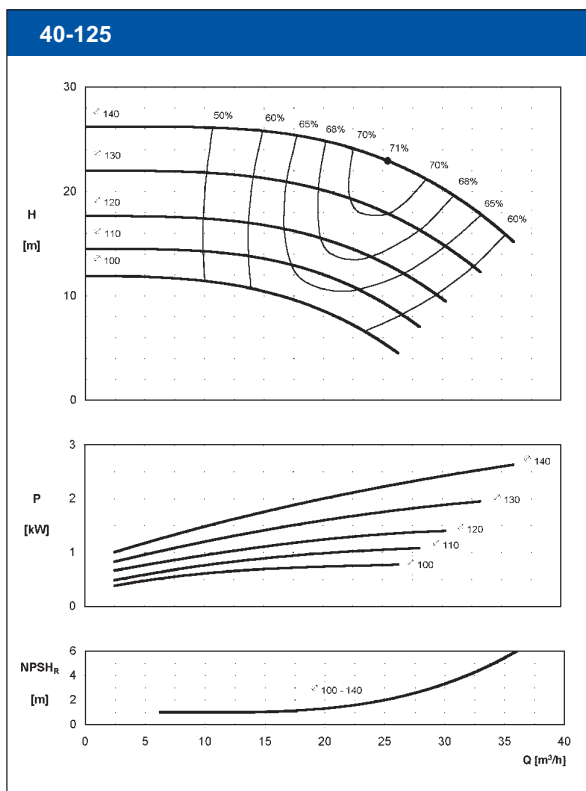
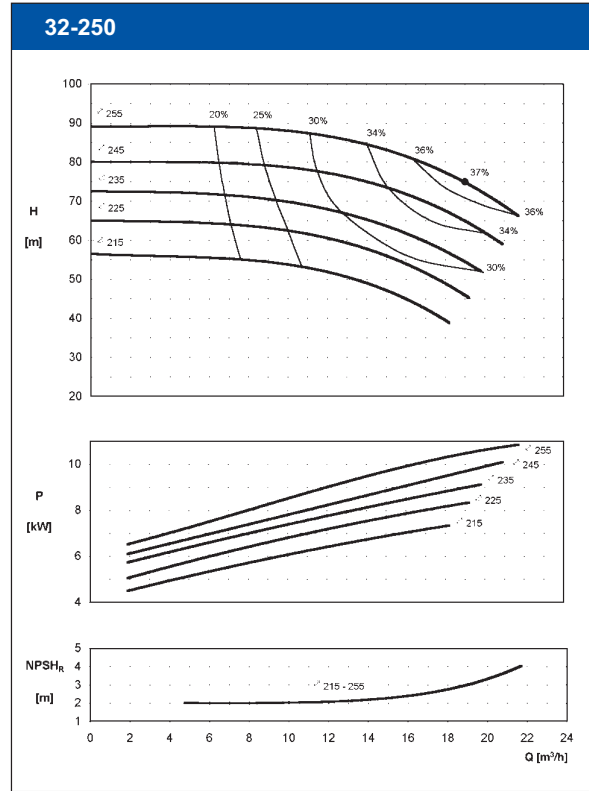
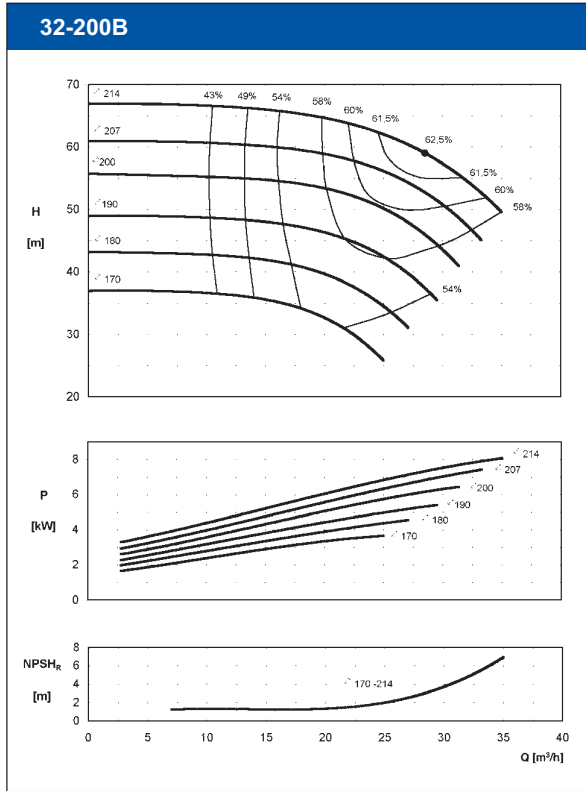
PERFORMANCE CURVE
2900 r.p.m.

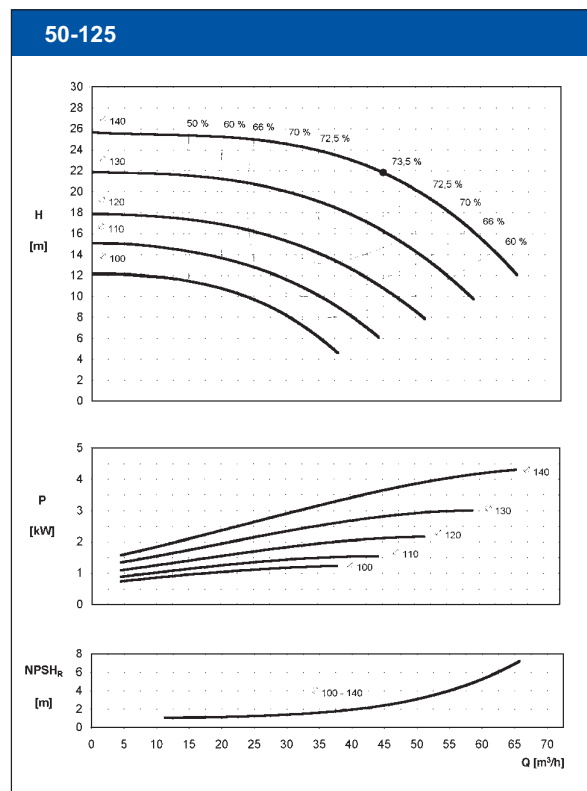
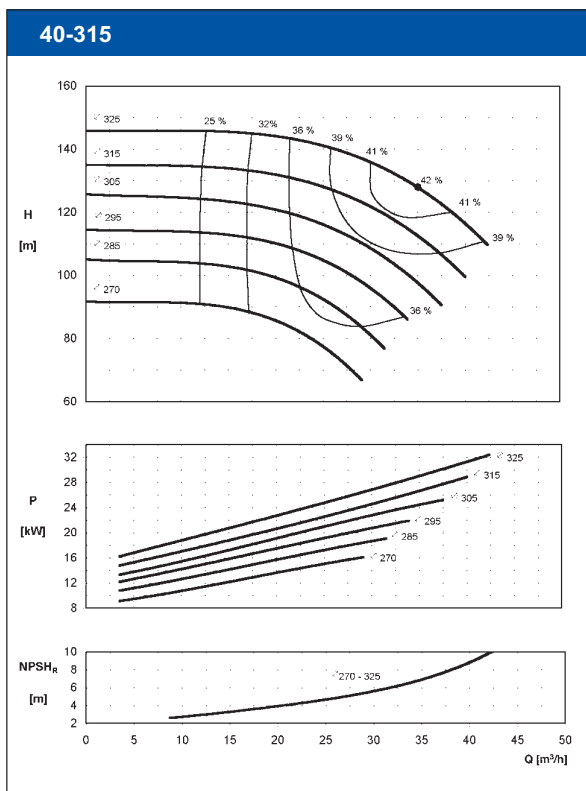
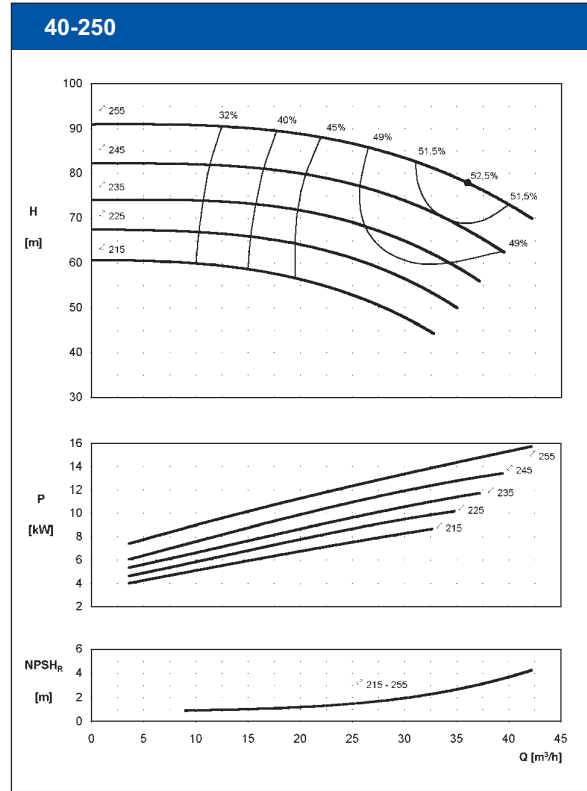
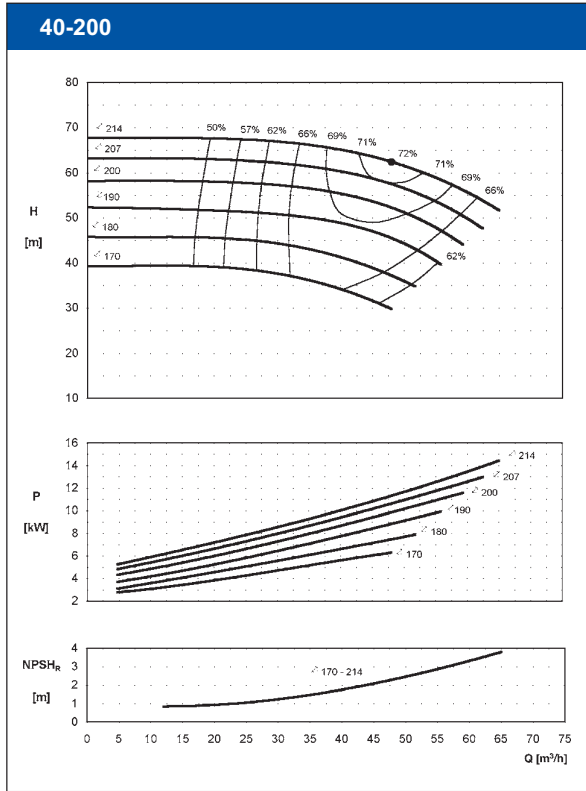
PERFORMANCE CURVE
2900 r.p.m.

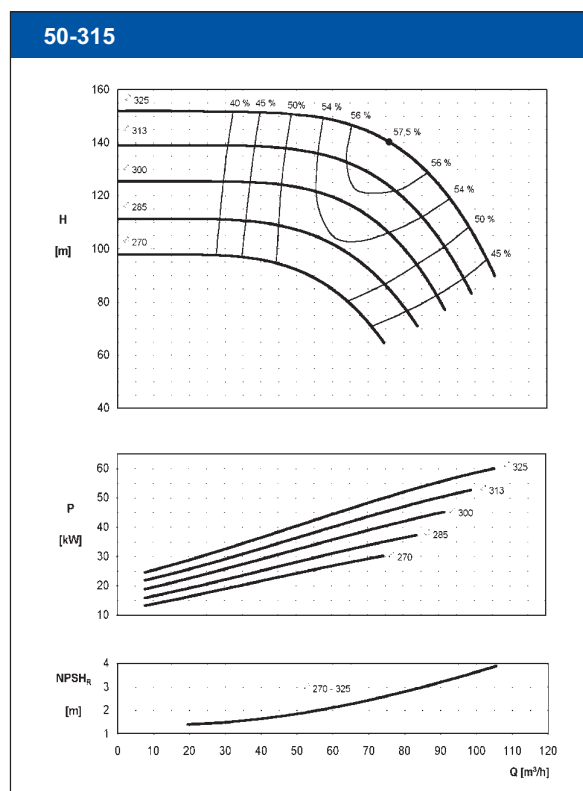
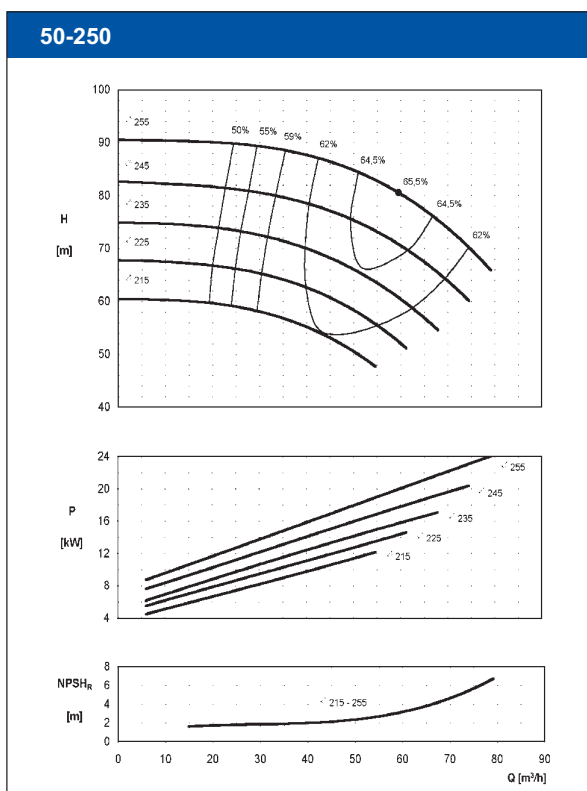
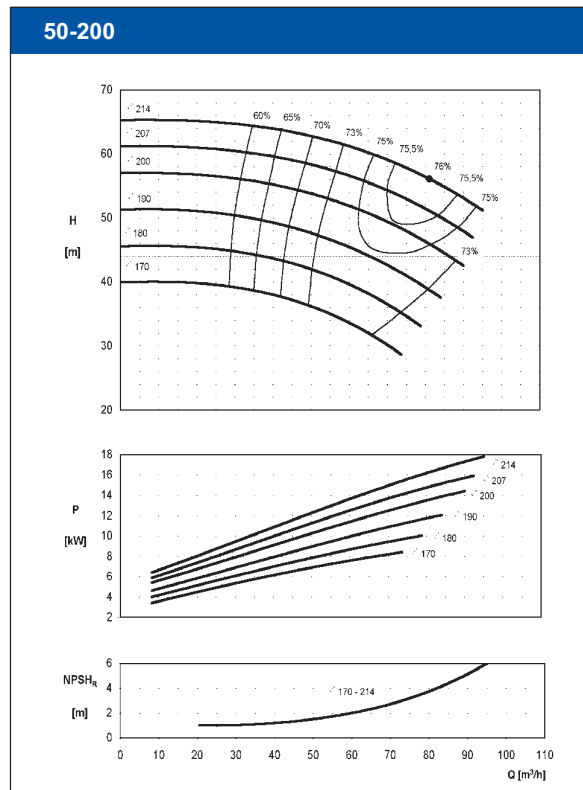
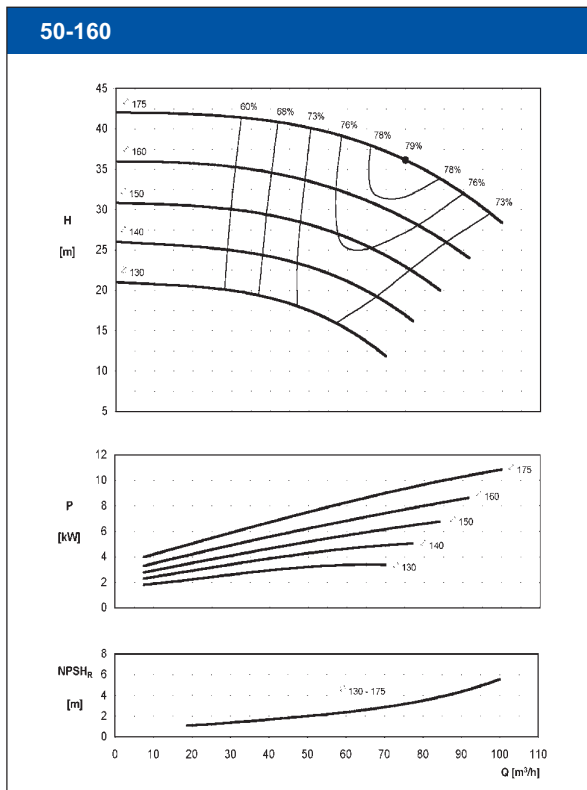
PERFORMANCE CURVE
2900 r.p.m.

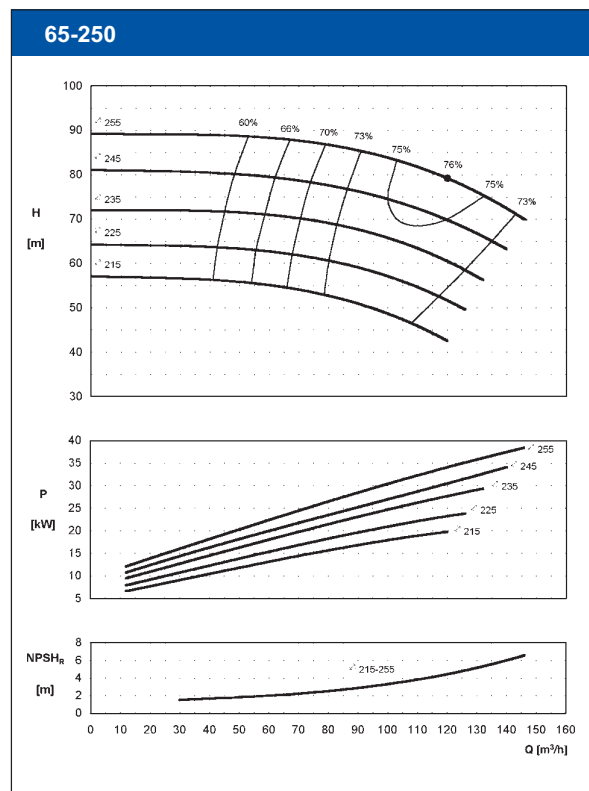
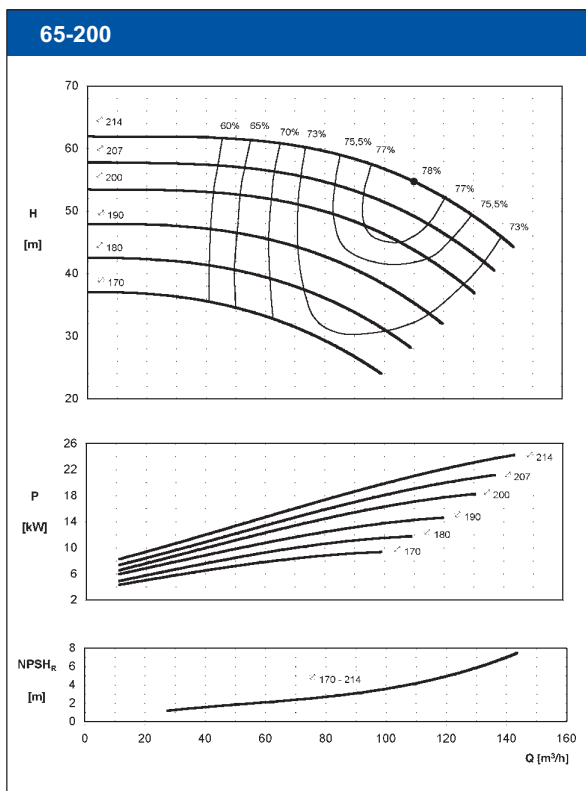
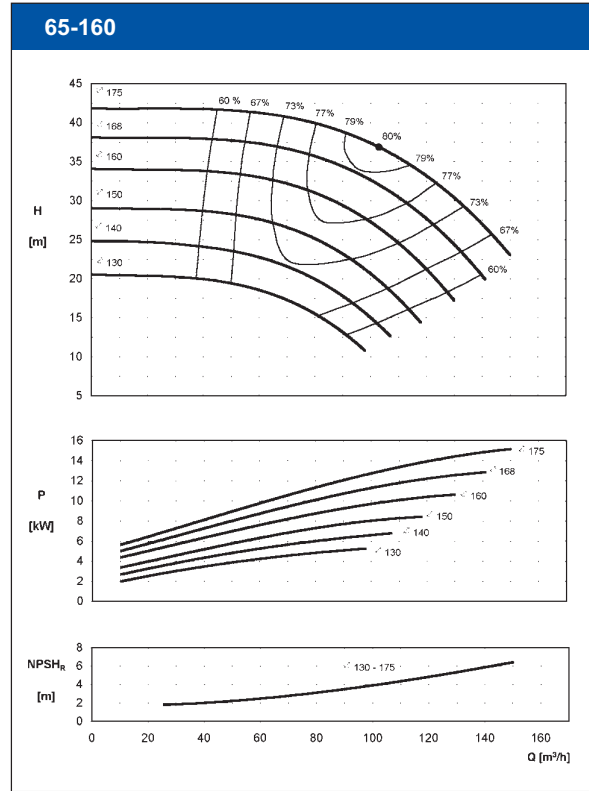
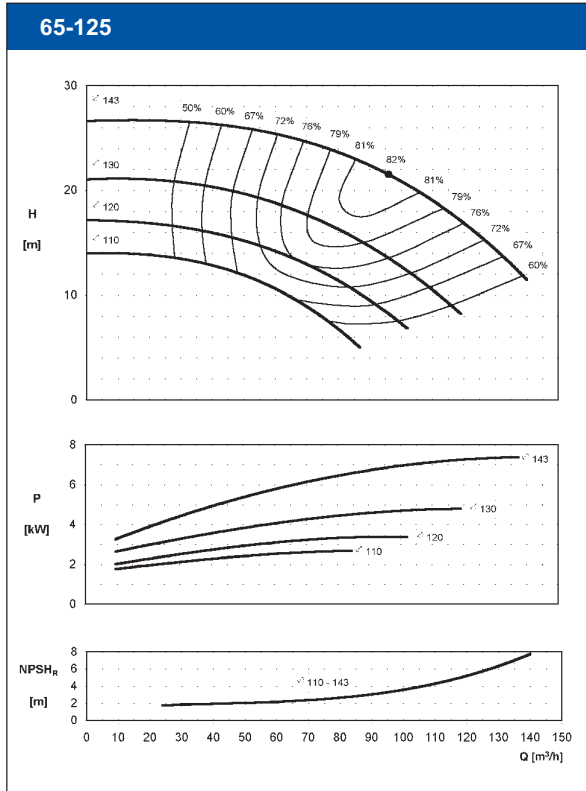
PERFORMANCE CURVE
2900 r.p.m.

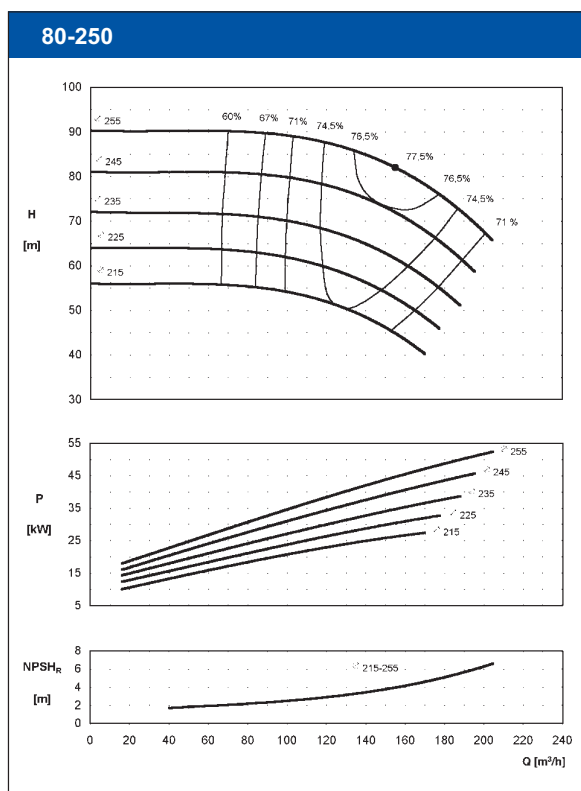
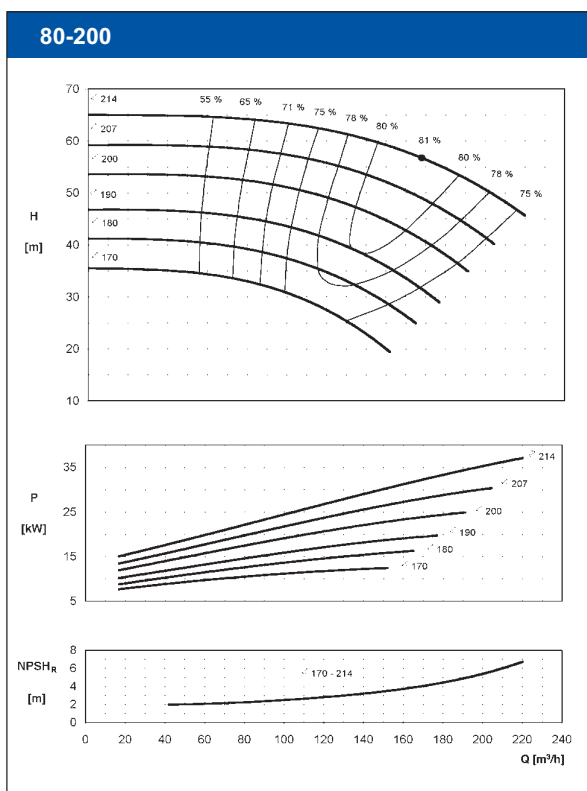
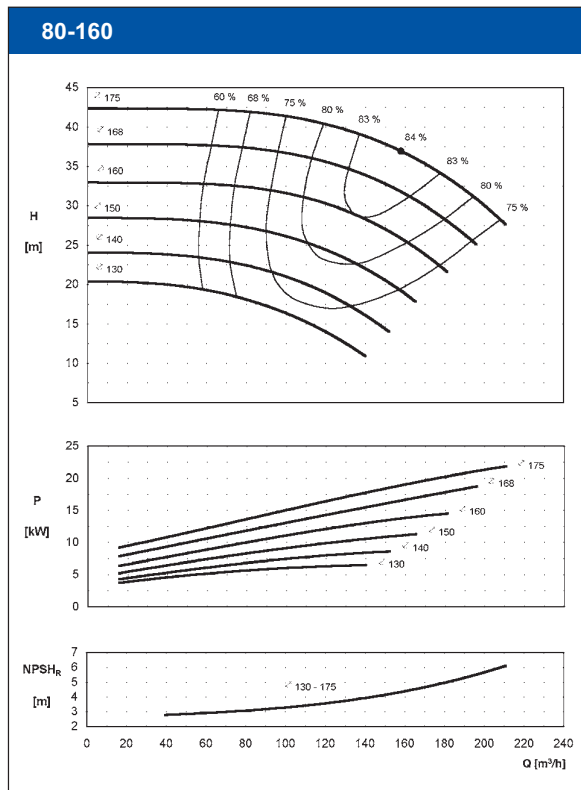
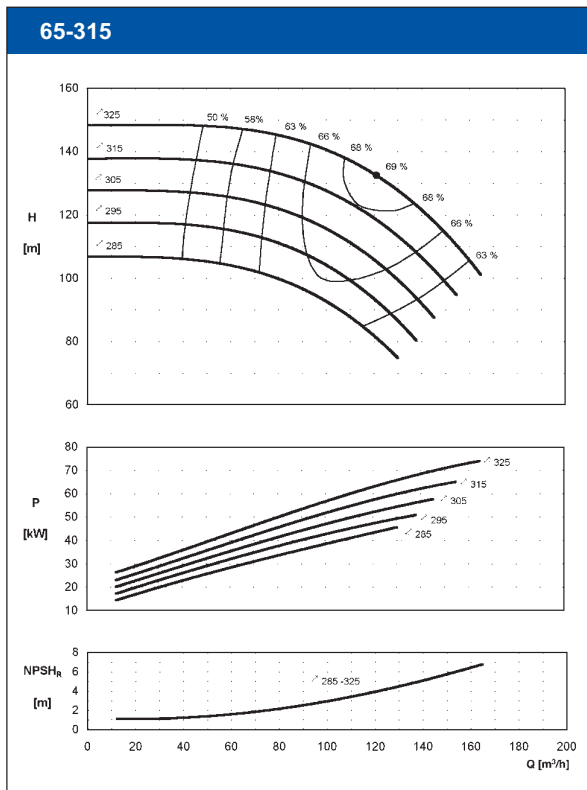
PERFORMANCE CURVE
2900 r.p.m.

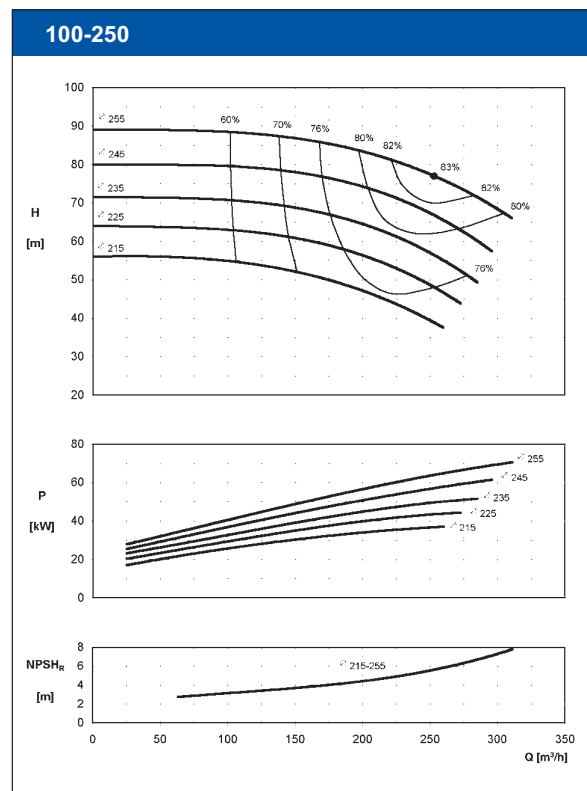
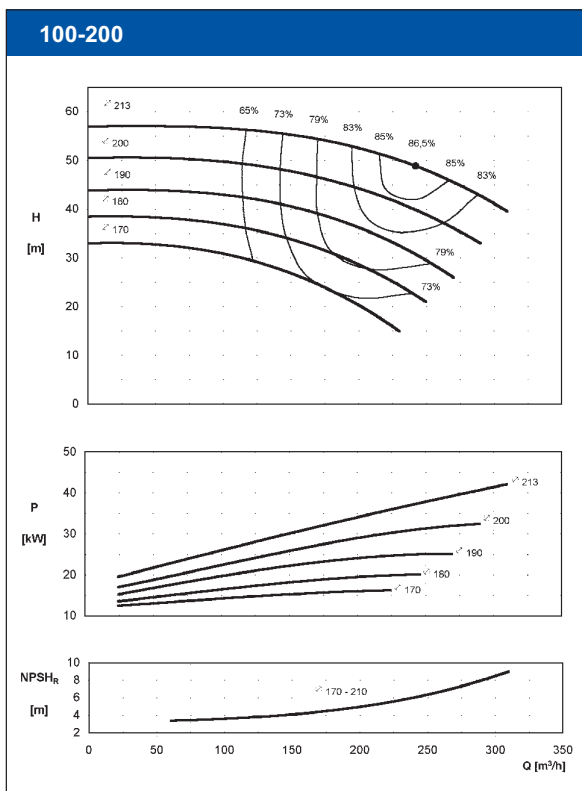
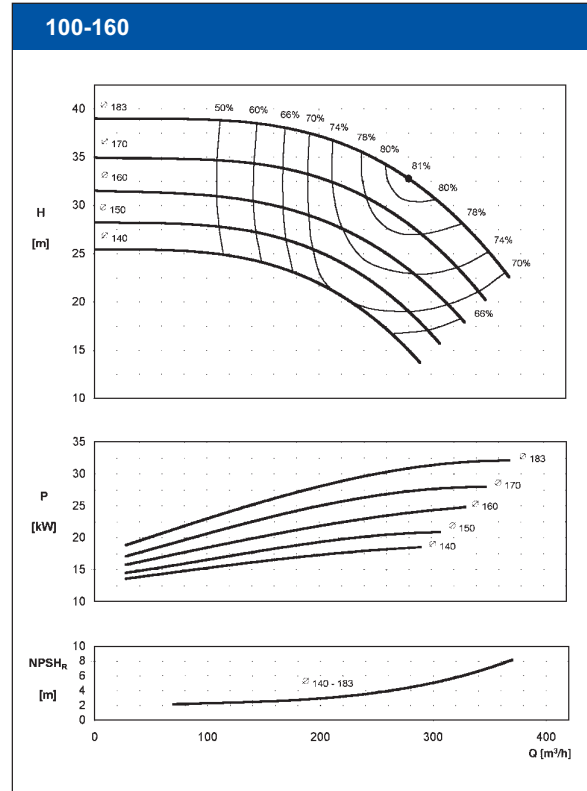
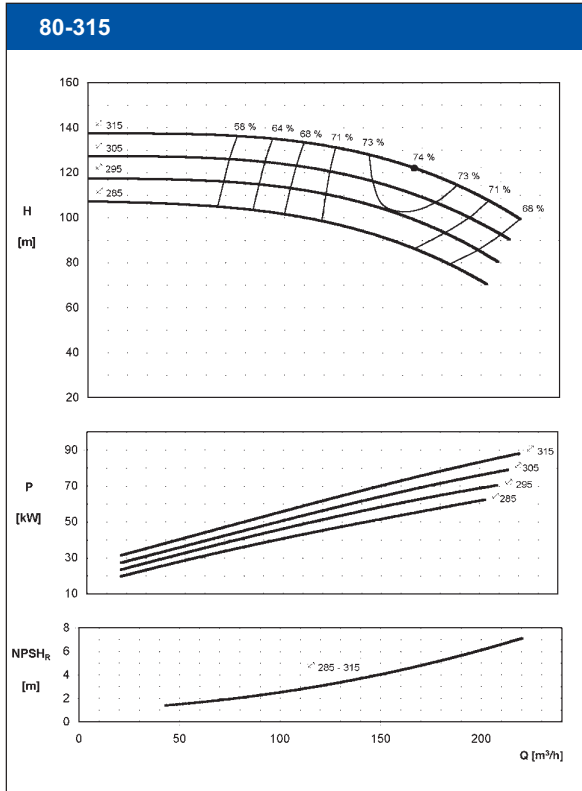
PERFORMANCE CURVE
2900 r.p.m.

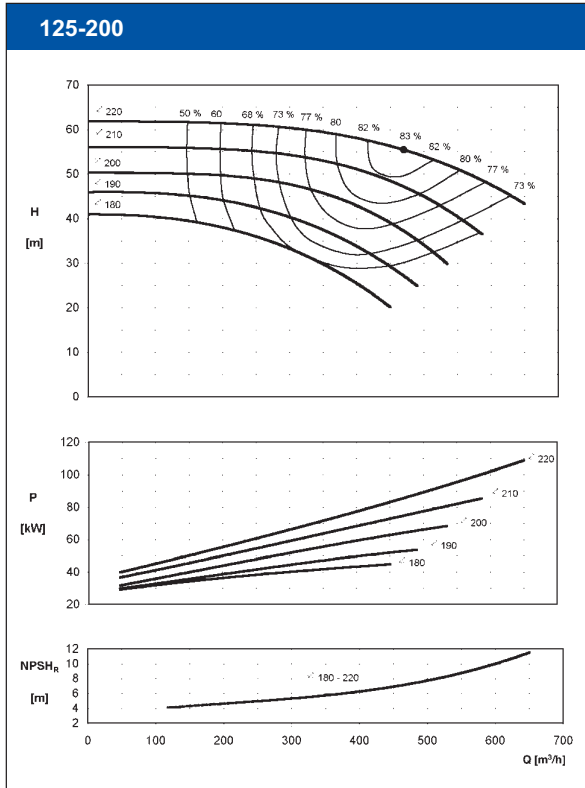
PERFORMANCE CURVE
2900 r.p.m.

DIMENSION - BEARING BRACKET 25, 35 & 45

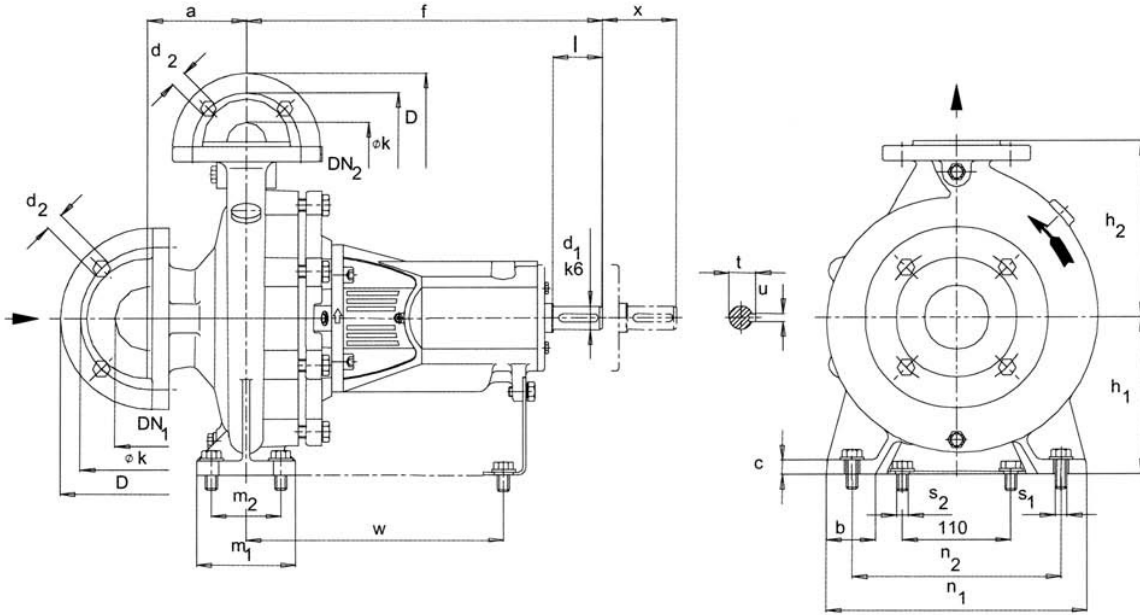

OUTLINE DIMENSION

Pump size	Sup.	Pump dimensions						Foot dimensions						Shaft end						Weight kg		
		DN2	DN1	a	f	h1	h2	b	c	m1	m2	n1	n2	s1*	s2*	w	x	d1	l		t	u
32-125	25	32	50	80	360	112	140	50	15	100	70	190	140	M12	M12	260	100	24	50	27	8	31
32-160						132	160					240	190									33
32-200						160	180					240	190									34
32-250 ¹⁾						180	225					320	250									46
40-125	25	40	65	80	360	112	140	50	15	100	70	210	160	M12	M12	260	100	24	50	27	8	28
40-160						132	160					240	190									30
40-200						160	180					265	212									36
40-250						180	225					320	250									46
40-315 ¹⁾	35	125	470	225	250	65	18	125	95	345	280	340	32	80	35	10	73	73				
50-125	25	50	65	100	360	132	160	50	15	100	70	240	190	M12	M12	260	100	24	50	27	8	30
50-160						160	180					265	212									36
50-200						180	225					320	250									40
50-250						225	280					345	280									50
50-315 ¹⁾	35	125	470	225	280	65	17	125	95	345	280	340	32	80	35	10	88	88				
65-125	25	65	80	100	360	160	180	65	15	125	95	280	212	M12	M12	260	100	24	50	27	8	33
65-160						180	200					320	250									39
65-200						200	225					320	250									45
65-250						225	280					400	315									70
65-315	35	125	470	225	280	80	18	160	120	360	280	340	32	80	35	10	92	92				
80-160	25	80	100	125	360	180	225	65	15	125	95	320	250	M12	M12	260	140	24	50	27	8	43
80-200	200					250	360					280	60									
80-250	250					315	400					315	75									
80-315	280					355	435					355	95									
80-400 ¹⁾	45	125	530	280	355	80	18	160	120	435	355	370	42	110	45	12	143	143				
100-160 ¹⁾	35	100	125	140	360	200	280	80	18	160	120	360	280	M16	M12	340	140	32	80	35	10	78
100-200						225	315					400	315									70
100-250						250	315					400	315									85
100-315						280	355					435	355									104
100-400	45	125	530	280	355	100	18	200	150	500	400	370	42	110	45	12	177	177				
125-200 ¹⁾	35	125	150	140	470	250	315	80	18	160	120	400	315	M16	M12	340	140	32	80	35	10	100
125-250						280	355					400	315									102
125-315						315	400					435	355									151
125-400						350	450					500	400									188
150-200 ¹⁾	35	150	200	160	470	280	400	100	20	200	150	550	450	M20	M12	340	140	32	80	35	10	123
150-250 ¹⁾						315	450					500	400									128
150-315						350	450					550	450									170
150-400						400	500					600	450									205
200-250 ¹⁾	45	200	200	160	590	280	400	100	22	200	150	500	400	M20	M12	430	180	42	110	45	12	230

¹⁾ Transpump pump sizes, not included in DIN 24255 / EN 733. Flanges drilled according to ANSI 150 on request.
 * Slots suitable for bolts with dimensions indicated. Bolts are not included in the bare shaft pump standard scope of supply.

DIMENSION - BEARING BRACKET 55 & 65

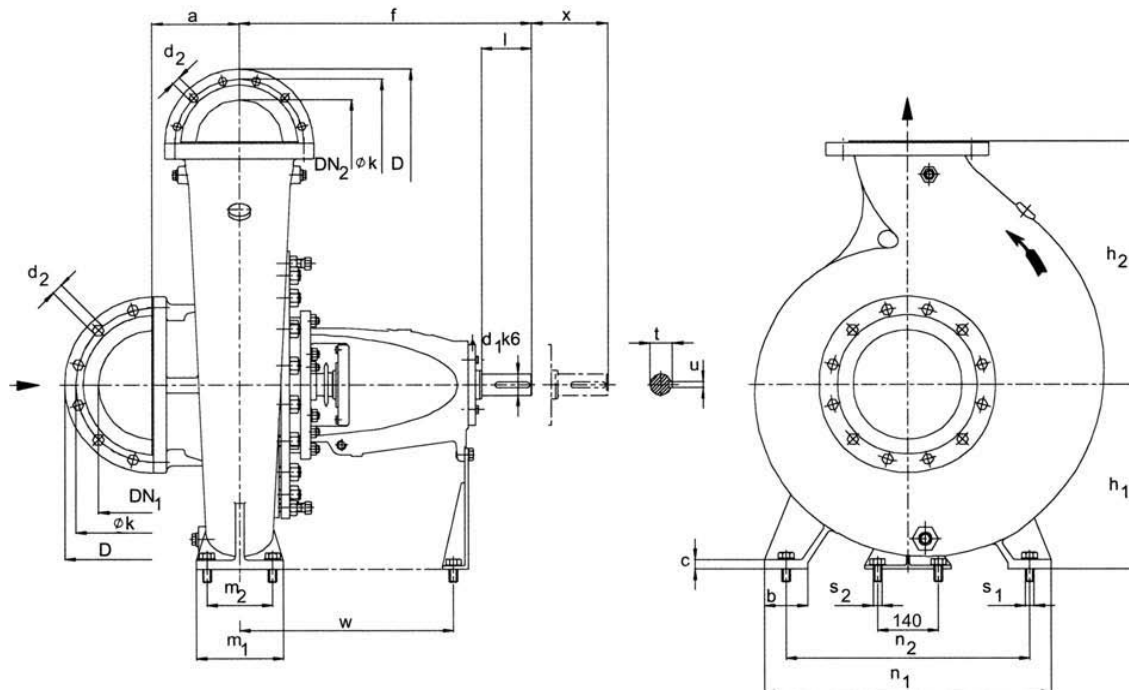

OUTLINE DIMENSION

Pump size	Sup.	Pump dimensions						Foot dimensions						Shaft end						Weight kg		
		DN2	DN1	a	f	h1	h2	b	c	m1	m2	n1	n2	s1*	s2*	w	x	d1	l		t	u
150-500 ¹⁾	55	150	200	180	670	400	500	100	22	200	150	640	540	M20	M16	489	180	50	115	53.5	14	335
200-315 ¹⁾	55	200	250	200	670	355	450	100	22	200	150	550	450	M20	M16	489	180	50	115	53.5	14	310
200-400 ¹⁾				180		500	340															
200-500 ¹⁾				200		425	560					395										
250-300 ¹⁾	55	250	300	305	655	425	550	120	28	240	190	660	560	M20	M16	474	180	50	115	53.5	14	416
250-315 ¹⁾				670	375	560	424															
250-400 ¹⁾				720	400	600	464															
250-500 ¹⁾	65	300	350	300	450	670	670	120	29	250	190	700	600	M24	M16	508	180	60 ²⁾	145	64	18	589
300-400 ¹⁾					425	670						620	660			503						620
300-500 ¹⁾					480	670						760	660			508						720

¹⁾ Transnom pump sizes, not included in DIN 24255 / EN 733. Flanges drilled according to ANSI 150 on request.

²⁾ For these sizes the clearance corresponds to m6.

* Slots suitable for bolts with dimensions indicated. Bolts are not included in the bare shaft pump standard scope of supply